

50 Hz

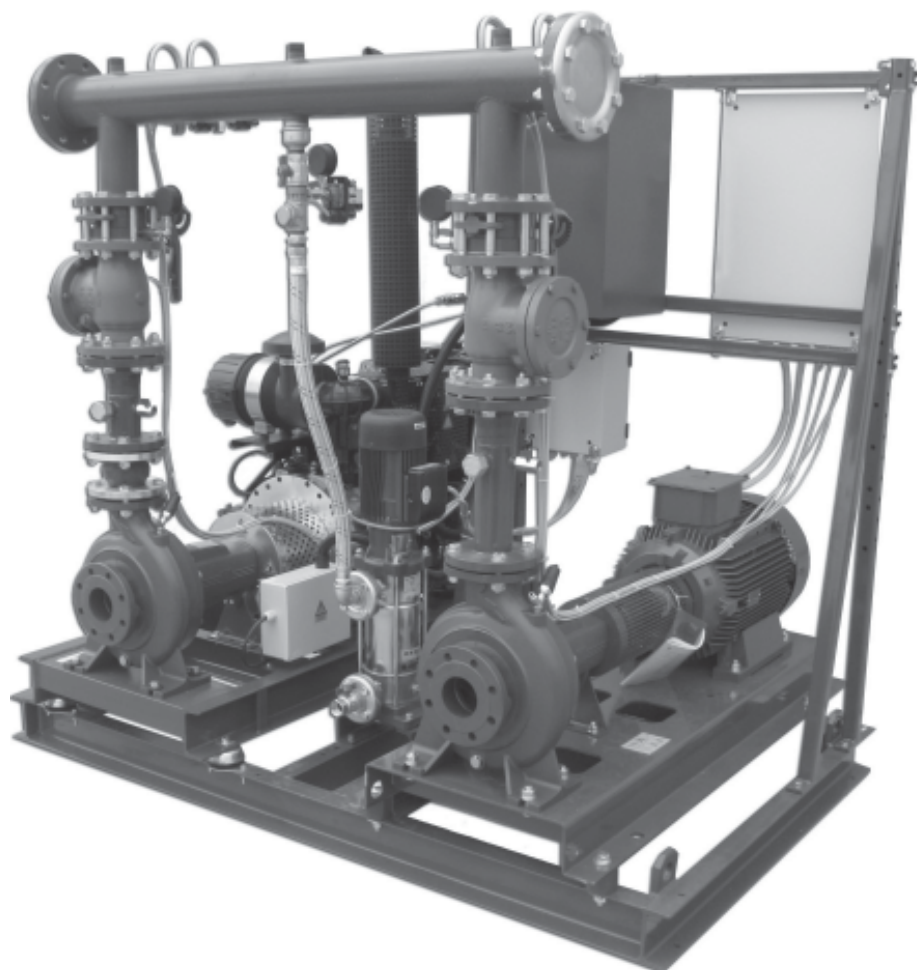

GEN Series with Diesel Engine Pumps

FIRE-FIGHTING BOOSTER SETS EN 12845, HIGH EFFICIENCY ELECTRIC PUMPS

FHF and SHF SERIES WITH HIGH EFFICIENCY MOTORS AND DIESEL ENGINE PUMPS

Cod. 191000461 Rev.A Ed.11/2011

 **LOWARA**
a xylem brand

CONTENTS

General introduction	5
Characteristics of electric pumps – diesel engine pumps	10
Accessories and main components	13
Choice and selection	26
GEN..D/FHF series	35
Range	37
Hydraulic performance tables	41
Electrical performance tables	53
DFHF series	55
GEN..00D/FHF series	59
GEN..01D/FHF series	63
GEN..10D/FHF series	69
GEN..11D/FHF series	73
Hc pressure drop curve in suction kit	79

CONTENTS

GEN..D/SHF series	91
Range	93
Hydraulic performance tables	96
Electrical performance tables	106
DSHF series	107
GEN..00D/SHF series	111
GEN..01D/SHF series	115
GEN..10D/SHF series	119
GEN..11D/SHF series	123
Hc pressure drop curve in suction kit	127
Accessories	137
Product description by technical specifications	152

GEN SERIES OF BOOSTER SETS

GENERAL INTRODUCTION – PRODUCT DESCRIPTION

The GEN booster sets are built in conformity with EN12845 for automatic sprinkler systems and with UNI10779 for hydrant systems.

In accordance with the above standards, all the main components of the booster set are factory connected and assembled.

The configuration of the booster set depends on the number of pumps installed and on the type of electric motor or diesel engine, consistently with the type of supply chosen for the fire-fighting system from among those described in the standard. The water supply can be single, superior, duplicated or combined. Two main service pumps, one backing up the other, are normally installed for fire-fighting systems. The choice of electric motors or diesel engines depends on the level of reliability required from the system. In practice, fire-fighting booster sets have one electric service pump and one diesel service pump.

Point 10.2 of EN 12845 states that for superior or duplicate water supplies, and if more than one pump is installed, no more than one service pump can be driven by the electric motor.

This concept means that mixed assemblies, comprising electric or diesel pumps, have to be installed.

This does not mean that it is not possible to have two electric pumps, one backing up the other, if the ascertained fire risk is low (single supplies) or if a diesel generator is already incorporated in the system.

The Lowara GEN series of booster sets are therefore configured according to system requirements and initial considerations. They are also factory tested and comprise the following:

- One or two horizontal or vertical service pumps with the same hydraulic performance level, driven by an electric motor.
- Two horizontal service pumps with the same hydraulic performance level, driven by an electric motor and a diesel engine.
- A horizontal service pump driven by a diesel engine.

The booster set is built and completed with the following main components:

- A Lowara SV series jockey electric pump (if required), controlled by an electric panel in the automatic mode. The jockey pump is automatically started and stopped by its pressure switch in order to restore supply pressure. This prevents the service pumps from starting and activating the main alarms.
- A control panel for each service pump.
- Two pressure switches for each service pump (if the first fails, the second repeats permission for the pump to start).
- On the discharge side of each service pump there is a on-off valve, a check valve and a tap for connection to the priming circuit for suction lift installations. Moreover, if the service pump works with a closed discharge line, a water recirculation tap has been applied to the pump body in order to prevent the pump from overheating.
- Discharge manifold connected to each service pump, fitted with a weld-on flange for connection to the system.
- Single base containing all the booster set components within a compact structure and ready for installation.

To complete the pump station as requested by the standard, the GEN series of booster sets are fitted with the following accessories:

- Suction side kit.
- Flow meter.
- Alarm panel.
- Set of spare parts for diesel engines.
- Priming tank with accessories (for suction lift installations).
- 24L diaphragm tanks.

SET IDENTIFICATION CODE

DIESEL ENGINE PUMP

D FHF E A X / 32-200/D204 / B / IP55

- Options:
- IP55 = Panels with IP55 protection.
- _ = Language group IT, EN, FI, PT.
- B = Language group EN, FR, DE, NL.
- Pump model.
- X = Automatic shut-off.
- A = Version with periodic self-test.
- EN 12845 Fire-fighting series.
- FHF = Pump code.
- SHF = Pump code.
- Diesel engine pump.

DIESEL ENGINE PUMP SET

GEN A X 00D / FHF 32-200/D204 / B / IP55

- Options:
- IP55 = Panels with IP55 protection.
- _ = Language group IT, EN, FI, PT.
- B = Language group EN, FR, DE, NL.
- FHF = Pump code.
- SHF = Pump code.
- Diesel engine pump only.
- X = Automatic shut-off.
- A = Version with periodic self-test.
- GEN Fire-fighting series.

SET WITH DIESEL ENGINE PUMP AND ELECTRIC PUMP

GEN Y B X 1 1 D / FHF 32-200/40/D204 + 1SV15 / B / IP55

- Options:
- CP = Clean contacts in electric pump panel.
- IP55 = Panels with IP55 protection.
- KV = Voltmeter kit.
- _ = Language group IT, EN, FI, PT.
- B = Language group EN, FR, DE, NL.
- Jockey pump code.
- FHF = Service pump code.
- SHF = Service pump code.
- D = With diesel engine pump.
- 0 = Without electric jockey pump.
- 1 = With electric jockey pump.
- 0 = Without electric service pump.
- 1 = With 1 electric service pump.
- X = Automatic shut-off.
- B = Basic version (only mark if electric service pump is present).
- A = Version with periodic self-test.
- Electric service pump electric start-up
- D = Direct start (Up to and including 22 kW).
- Y = Star/delta start.
- I = Impedance start.
- GEN Fire-fighting series.

REFERENCE STANDARDS

- The Lowara fire-fighting booster sets are EC certified in conformity with the following directives:
 - Machine Directive 2006/42/EC.
 - Low Voltage Directive 2006/95/EC.
 - Electromagnetic Compatibility Directive 2004/108/EC.
- The electric pump performance is declared to be in accordance with the following standard:
ISO 9906-A Rotodynamic pumps – hydraulic performance tests and acceptance criteria.
- The fire-fighting booster sets conform to the European fire-fighting Standard EN 12845.
The automatic shut-off versions also conform to the UNI 10779 Italian Standard for hydrant systems.

GEN SERIES OF BOOSTER SETS FUNCTIONAL DIAGRAM FOR POSITIVE SUCTION HEAD INSTALLATIONS

INTRODUCTION

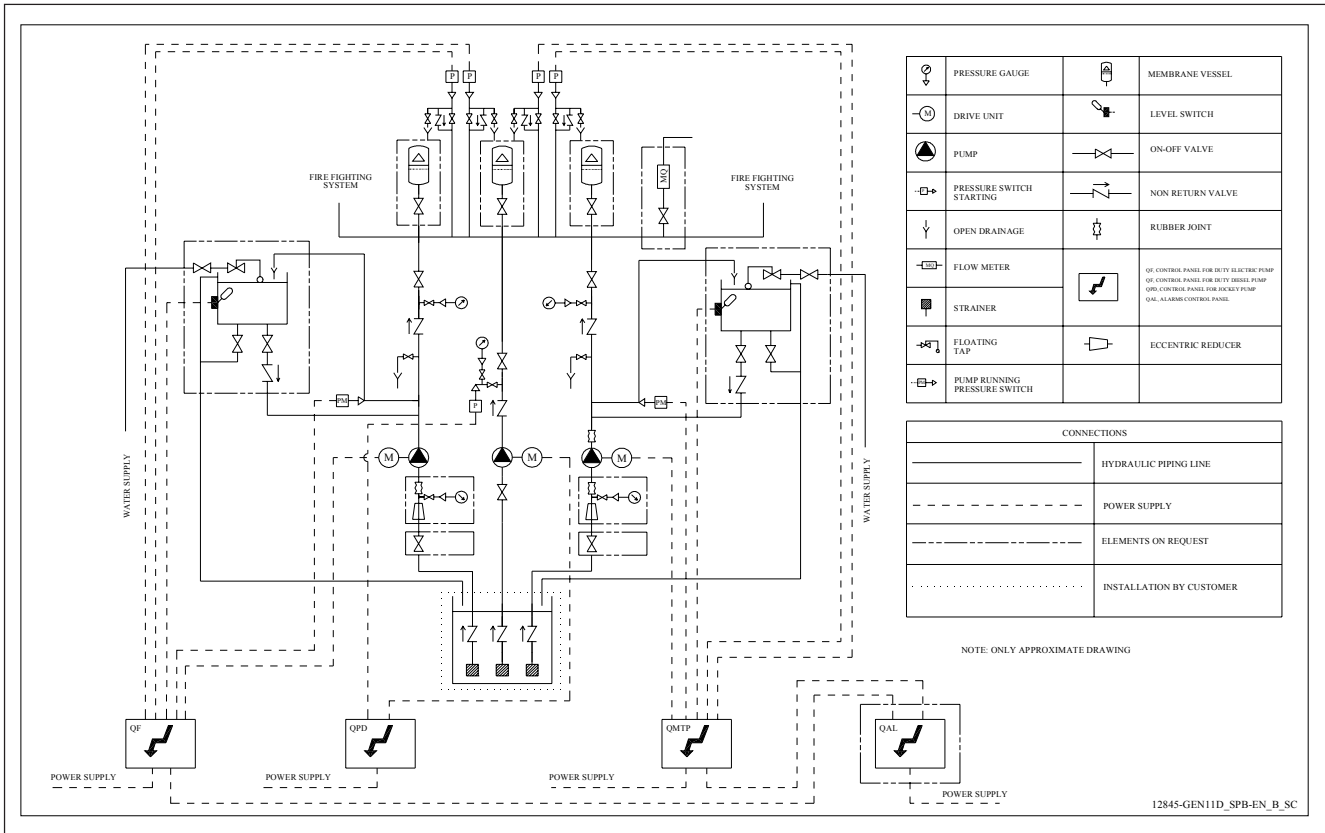

GEN SERIES OF BOOSTER SETS FUNCTIONAL DIAGRAM FOR SUCTION LIFT INSTALLATIONS

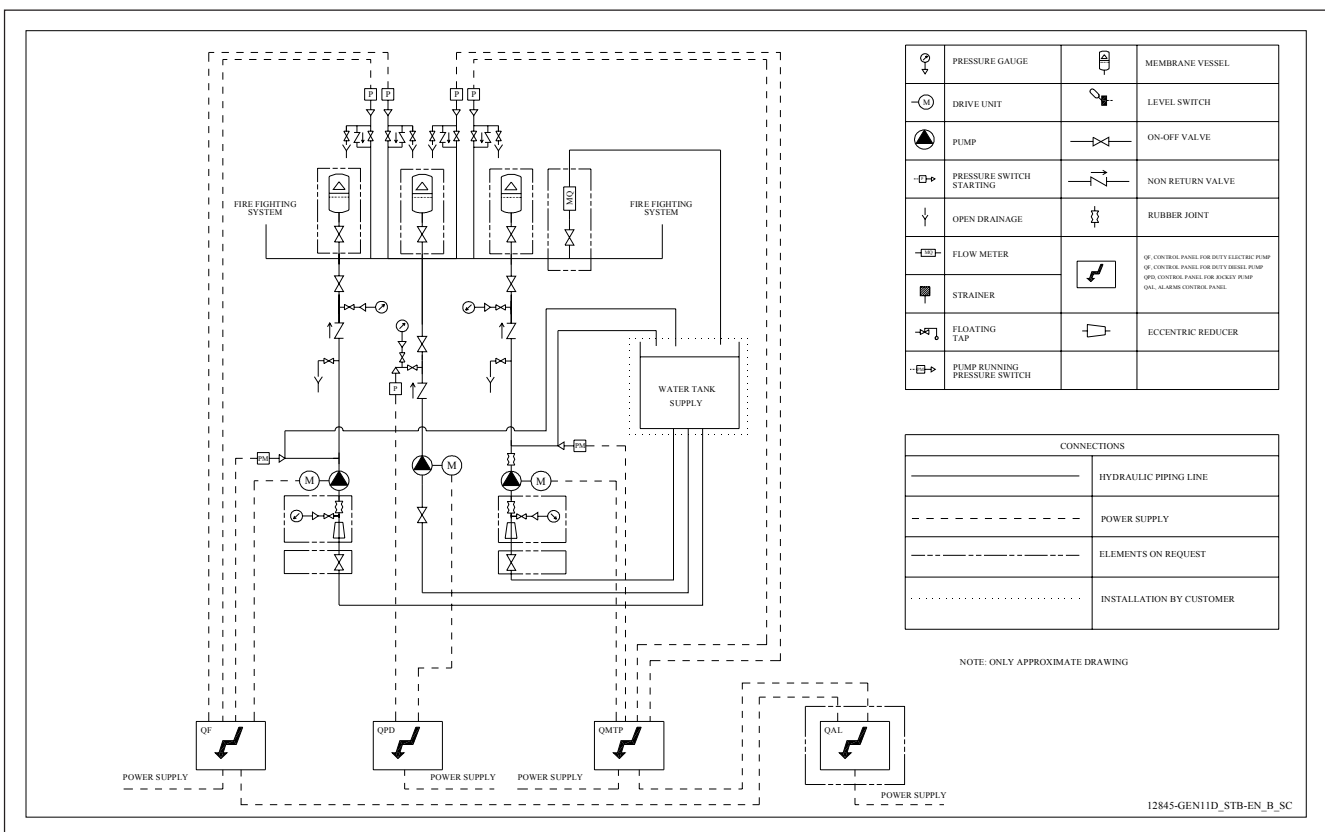

**GEN SERIES OF BOOSTER SETS
MECHANICAL CONFIGURATION**

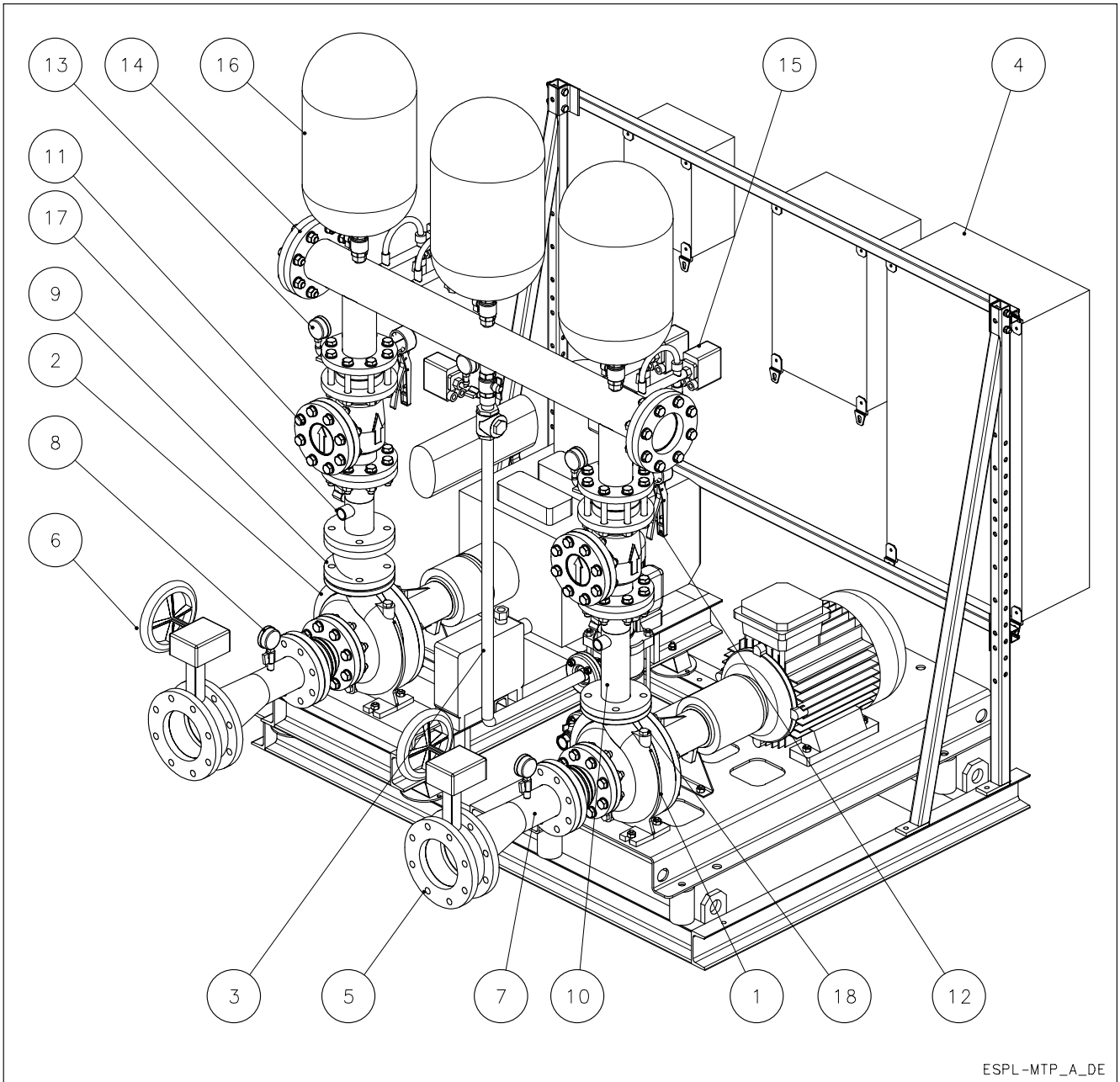

ESPL-MTP_A_DE

INTRODUCTION

REF.	DESCRIPTION
1	electric service pump
2	diesel engine service pump
3	jockey pump discharge line
4	control panels
5	pump suction line
6*	on-off valve on suction line
7	eccentric divergent
8	vacuum pressure gauge
9	anti-vibration joint

REF.	DESCRIPTION
10	divergent on discharge line
11	inspectable check valve
12	on-off valve on discharge line
13	pressure gauge
14	discharge manifold
15	service pump starter (2x)
16	diaphragm tanks
17	priming circuit tap
18	recirculation circuit tap

* Optional in case of positive suction head installation.

CHARACTERISTICS OF THE PUMPS USED IN THE GEN SERIES OF BOOSTER SETS

1SV ELECTRIC PUMPS (JOCKEY PUMP)

- Multistage centrifugal vertical electric pumps. All metal parts in contact with pumped liquid are made of stainless steel.
- Version F: round flanges, in-line discharge and suction ports, AISI 304 (Standard version).
- Version N: round flanges, in-line discharge and suction ports, AISI 316 (Available on request).
- Reduced axial thrusts enable the use of **standard motors** that are easily found in the market. **Standard supplied IE2 three-phase surface motors $\geq 0,75$ kW are compliant with Regulation (EC) no. 640/2009.**
- Mechanical seal according to EN 12756 (ex DIN 24960) and ISO 3069.
- Easy maintenance. No special tools required for assembly or disassembly.
- For other characteristics, consult the relative dedicated technical catalogue.

FHF32, 40, 50, 65, 80, 100, 125 PUMP SERIES

- Single impeller cast iron horizontal centrifugal pump and shaft made of AISI 316L stainless steel. End suction and radial discharge ports.
- Impeller: made of AISI 316L stainless steel laser technology welded, for sizes 32, 40, 50, 65-125, or cast iron for sizes 65-160, 65-200, 65-250, 80, 100, 125.
- Hydraulic sizes and nominal diameter DN of suction and discharge ports according to EN 733 (ex DIN 24255).
- Flanges according to EN 1092-2 (ex UNI 2236) and DIN 2532.
- Motor: motor/pump coupling with bracket, support, flexible coupling with spacer coupling and aligning and anchoring base. **Standard supplied IE2 three-phase surface motors $\geq 0,75$ kW are compliant with Regulation (EC) no. 640/2009 and IEC 60034-30.** Performance levels according to EN 60034-1.
- **“Back pull out”** design, impeller, adaptor and motor can be extracted without disconnecting the pump body from the pipes.
- For other characteristics, consult the relative dedicated technical catalogue.

SHF32, 40, 50, 65, 80 PUMP SERIES

- Single impeller horizontal centrifugal pump with pump body and shaft made of AISI 316L stainless steel. End suction and radial discharge ports.
- Closed impeller made of AISI 316L stainless steel laser technology welded (for sizes 25, 32, 40, 50, 65-160/75 and 65-160/110A) or AISI CF8M cast stainless steel.
- Hydraulic sizes and nominal diameter DN of suction and discharge ports according to EN 733 (ex DIN 24255).
- Flanges according to EN 1092-1 (ex UNI 2236) and DIN 2532.
- Motor: motor/pump coupling with bracket, support, flexible coupling with spacer coupling and aligning and anchoring base. **Standard supplied IE2 three-phase surface motors $\geq 0,75$ kW are compliant with Regulation (EC) no. 640/2009 and IEC 60034-30.** Performance levels according to EN 60034-1.
- **“Back pull out”** design, impeller, adaptor and motor can be extracted without disconnecting the pump body from the pipes.
- For other characteristics, consult the relative dedicated technical catalogue.

MAIN COMPONENTS

FIRE-FIGHTING DIESEL ENGINE PUMP (D..)

- Diesel engine with coupling to service pump.
- Electric panel for control of diesel engine pump and battery charger.
- Diesel engine start circuit with two independent batteries.
- Double engine starting relay.
- Engine shut-off device from electric control (Electric stop).
- Fuel tank for diesel engine equipped with float.
- Base made of structural steel with epoxy powder painting RAL 5010.

The diesel engine pump is mounted on its own base complete with vibration-damping feet, and comes with a wall-mounted electric panel fitted with 3-metre cables (5 metre length available on request), fuel tank with wall or floor mounting depending on capacity, floor-mounted or on-board batteries. Special versions of additional diesel fuel tank available on request.

A panel mounting bracket kit for floor mounting and a jockey pump kit can be supplied on request.

The installation of the diesel engine must provide for adequate ventilation and exhaust of combustion fumes.

FIRE-FIGHTING SETS WITH DIESEL ENGINE PUMP (GEN..00D) FIRE-FIGHTING SETS WITH ELECTRIC PUMP AND DIESEL ENGINE (GEN..D)

- On/off valves on the delivery side of each pump, ball valves with lever handle for diameters up to and including 1" 1/2 butterfly valve with lever handle from DN50 to DN100 diameter, butterfly valve with handwheel and reduction manual gear for DN125 diameter and above. Device for monitoring ON/OFF status included. Electrical connections by customer.
 (Lockable kit available on request).
- Recirculation device for each service pump.
 The re-circulation device allows a minimum capacity in order to prevent the pump overheating when working with closed delivery. It includes the activation pressure switch for the alarms of the pumps running, the test valve for checking the seal of the check valves, the couplings for any connecting pipes to the priming tank in the case of suction lift installation. The connection of each re-circulation to the suction tank or the priming tank is to be seen to by the person installing the equipment.
- Pressure gauge on the delivery side of each service pump between check valve and on/off valve.
- Inspectable check valve on the discharge side of each pump. Threaded coupling for diameters up to 1"1/2 included, flanged coupling for larger sizes.
- Painted iron delivery manifold (PN 16) and threaded stubs with relative caps for connecting any 24 litre membrane tanks. Blind and welding zinc-plated flanges.
- Two start-up pressure switches for every service pump.
 For the electric service pumps, start-up takes place through the pressure switch, but it must be manually stopped using the key-operated selector switch on the panel (excluding the version with automatic shut-off). For the electric jockey pump, if present, both start-up and stopping are determined by the pressure switch.
- Start-up pressure switch circuit for the service pump, including connecting pipes for the delivery manifold, recirculation circuit.
 This circuit includes on/off valve, a non-return valve, a discharge valve and various pipe fittings. The configuration of the circuit allows the pressure switch to intervene also when the relative on/off valve is closed.
- Various pipe fittings (copper, zinc-plated steel).
- Base made of bent sheet or structural iron with epoxy powder painting RAL 5010.
- Control panel frame made of structural iron with epoxy powder painting RAL 5010.
- Diesel engine with coupling to service pump.
- Vibration-damping joints on discharge side.
- Electric panel for control of diesel engine pump and battery charger.
- Diesel engine start circuit with two independent batteries. Length of cable connecting the batteries to the connection box 3 m.
- Double engine starting relay.
- Engine shut-off device from electric control (Electric stop).

- Fuel tank for diesel engine. Special versions of additional diesel fuel tank available on request.
- Electric panel for each electric service pump.
Starting: Direct (DOL) up to and including 22 kW, star/triangle from 30 kW up.

The diesel engine pump is mounted on its own base complete with vibration-damping feet, and comes with a wall-mounted electric panel fitted with 3-metre cables (5 metre length available on request), fuel tank with wall or floor mounting depending on capacity, floor-mounted or on-board batteries depending on size. A panel mounting bracket kit for floor mounting and a jockey pump kit can be supplied on request. The installation of the diesel engine must provide for adequate ventilation and exhaust of combustion fumes.

The control panels for the electric pumps up to 55 kW power supply are fixed on bracket. For higher powers, the control panels for electric pump service are floor mounted, instead the jockey electric pump panel is wall mounted fixed.

Sets featuring a single diesel engine pump plus jockey pump are equipped with electric jockey pump with 1 x 230V single-phase power supply.

SUCTION KIT

The set is supplied with its suction side free from components.

On request, for the SUCTION side of the individual service pump, TWO versions are available according to the system's installation type:

• POSITIVE SUCTION HEAD and SUCTION LIFT KIT

Kit suitable for positive suction head or suction lift installation.

The suction side of the individual pump includes:

- Anti-vibration joint to attach to the pump inlet.
- Eccentric cone or flanged stub pipe.
- Vacuum pressure gauge.
- On/off butterfly valve (optional in case of positive suction head installation) with lever handle for diameters up to DN100, butterfly valve with handwheel and reduction manual gear for DN125 and higher. Device for monitoring ON/OFF status included. Electrical connections by customer.
(Valve lock kit available on request).
- Weld-on flange.

Conforming to the requirements of the EN 12845 Standard (chapter 10.5 and chapter 10.6).

These requirements are connected with the type of installation and the measurement of the piping sections. (see tables on pages 140-143).

OTHER VERSIONS

As well as the basic GENDB versions (direct start-up), GENYB (star triangle start-up), GENIB (impedance start-up), the following versions are also available:

• GEN..A

With periodic self-test function.

There is a self-test circuit including a weekly clock on the electric panel of each electric service pump. For the time and date pre-set, the pump is started up and kept functioning for 1 minute. During this interval the check circuit checks that the pressure in the re-circulation circuit closes the pressure switch contact of the pump which is running. In the case of irregularities, the relative auxiliary self-test alarm relay available for remote signalling is activated and memorised.

The EN12845 Standard does not provide for the presence of a self-test circuit but asks for periodic checks to be carried out by the user, hence the periodic self-test function cannot substitute the above checks.

• GEN..X (For fire hydrant systems, UNI 10779)

With automatic shut-off.

There is an automatic shut-off circuit on the electric panel of each electric service pump.

In certain situations, it allows automatic shut-off once the system pressure has been kept at higher values than the start-up values for at least twenty minutes.

The self-test and automatic shut-off versions are available for each type of GEND., GENY., GENI.. start-up and in combination between them (See identification codes page).

ACCESSORIES AVAILABLE ON REQUEST

- Protection against dry running for the electric jockey pump in one of the following versions:
 - Float switch, in case of suction lift.
 - Probes kit in case of suction lift (needs optional probe module in the electric jockey pump).
 - Minimum pressure switch, in case of positive suction head.
- Electric panel for remote status and alarm monitoring of one or two Lowara pumps installed in GEN fire-fighting booster sets, according to EN12845.

In the electric service pump mode, the following conditions are visualised: Motor powered, pump start-up request, pump running, failure to start.

In the diesel engine service pump mode, the following conditions are visualised: switch in non-automatic position, diesel engine fails to start after 6 attempts, pump running, controller failure.

Additionally: minimum suction tank or fuel level, minimum priming tank level, on-off valve on suction and discharge side not fully open.

All the above conditions, required by EN12845, are visualised with signal LED's and buzzers.

A buzzer alarm reset button and LED tester button are included.

The control unit is also fitted out to signal the following general alarms, if present:

- General alarm for incorrect electrical connection in the exchange contacts of: flow meter circuit valve, discharge pump, jockey pump status.
- Fault in electrical connection in the exchange contact relative to panel 1 (electric pump/diesel engine pump).
- Fault in electrical connection in the exchange contact relative to panel 2 (electric pump/diesel engine pump).
- Jockey pump overload; - Jockey pump running; - Discharge pump overload;
- Battery low; - No communication with ModBus system.

All the above conditions are visualised with signal LED's and on the display. The customer may decide to enable the buzzer. Further information available on page 144.

- Circuit for test flow of the service pumps. Includes the direct reading flow meter (sized according to the capacity of the service pump) according to the type of flow meter, connecting piping and straight piping upline from the instrument, on/off ball valve for diameters up to and including 2" butterfly valve with lever handle from DN65 to DN100 diameter, butterfly valve with handwheel and reduction manual gear for DN125 diameter and above. ON/OFF status monitoring included.
New model of flow meter (P6) for diameters up to and including DN80.
- Diaphragm tank with relative ball valve, in the same number as that of the pumps present, for dampening any pressure oscillations in the system. 24 litre model with maximum pressure 8, 10 and 16 bar or 20 litre model with maximum pressure 25 bar according to the maximum head of the pumps.
- Priming tank for each service pump, in the case of suction lift installation.
- Accessories for the priming tank such as float switch tap, level indicator, valves, automatic air discharger on each service pump, in the case of suction lift installation.



QAL12845 Panel

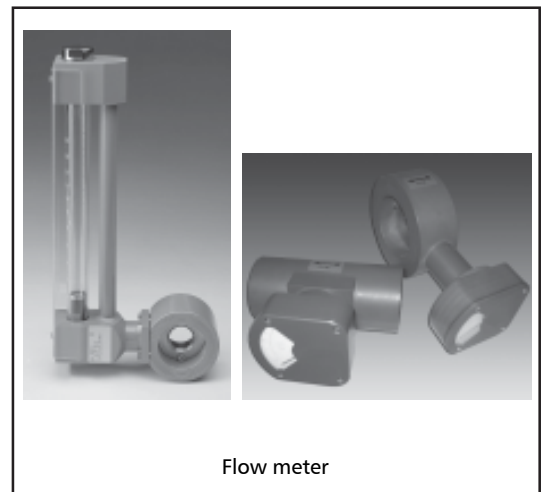

Flow meter

All the main characteristics of the priming tanks, the flow meters and the available membrane tanks are shown in the accessories section.

SPECIAL EQUIPMENT ON REQUEST

(Contact the Sales and technical Assistance Service)

Sets for pumping sea water with electric pumps, valves, manifold and AISI 316 piping or compatible alloys.

Non-standard supply power sets.

Sets with two diesel engine service pumps. (See page 15).

Sets with separate electric jockey pump supplied as a kit.

Sets installed inside prefabricated boxes for outdoor use.

Sets with oversized fuel tank.

Sets with diesel engine pump with compressed air start system.

Diesel engine pump with ambient air cooling device.

Notes

The set is supplied without a suction manifold in accordance with the EN12845 Standard (points 10.6.2.2 and 10.6.2.3) which provides for independent suction for each pump.

Please see the EN12845 Standard on fixed systems and fire extinguishing – Automatic sprinkler systems – Design, installation and maintenance? - for sizing the suction piping, define whether the installation is to be considered suction lift or positive suction head for the use limits.

The Standard ask that, whenever possible, the pumps are installed with positive suction head, otherwise priming tanks must be provided with suitable automatic devices for signalling and reintegration.

The EN12845 Standard states that the water pressure should not exceed 12 bar (point 8.2.1). In some applications it is possible to have pressures of over 12 bar (point 8.2.2).

In this case, pump sets with higher pressures than those within the regulatory limit are used.

The catalogue also shows booster sets with pump closing head up to 150 metres suitable for such installations.

SPECIAL EQUIPMENT ON REQUEST

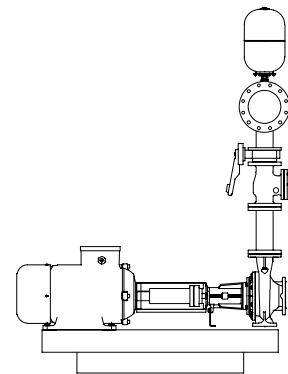
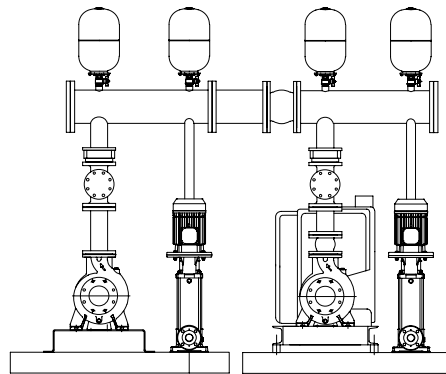

GENYAX12D

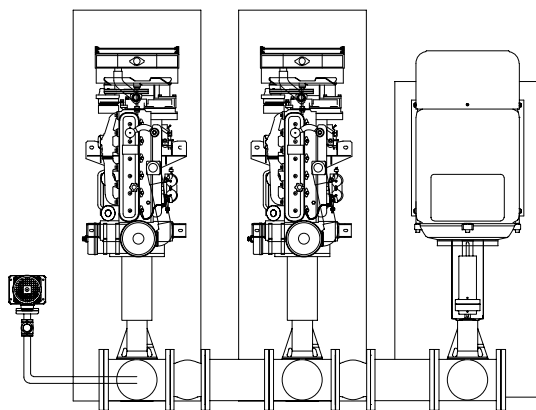
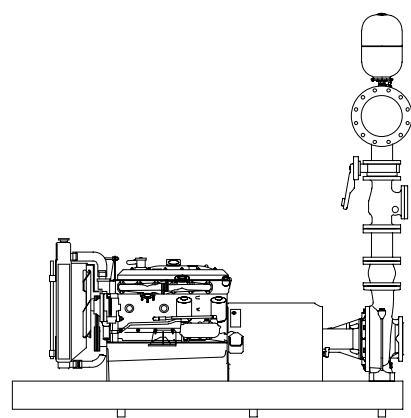
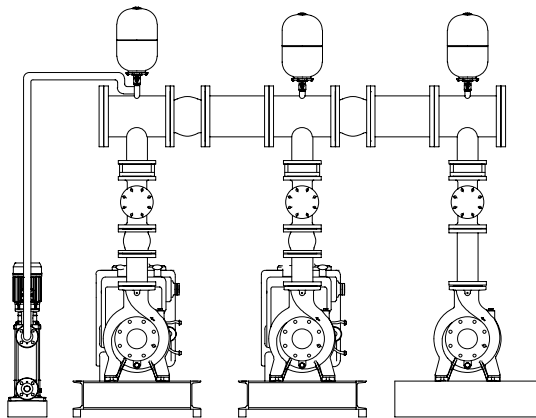
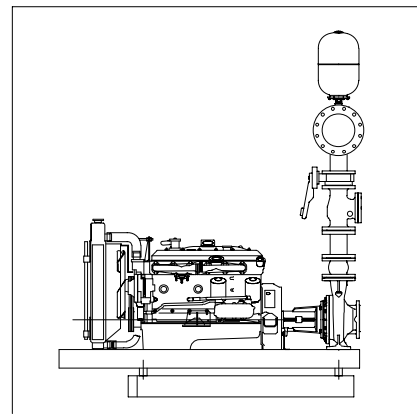
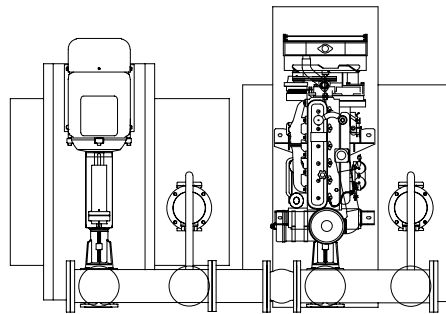

GENYAX11D2

GEN-SPECIAL_A_SC

INTRODUCTION

COMMAND PANEL FOR THE ELECTRIC SERVICE PUMP

Painted metal casing (IP 54) complete with:

- General door-locking switch.
- Analogical ammeter.
- "MAN – AUT – 0" selector with extractable key only in automatic position.
- Keyboard for indicating electric voltage presence, correct phase sequence (three phase power supply), start-up request, pump functioning and no start-up, through LED lamps, lamp test button and starting and stopping buttons, according to the provisions of EN12845 paragraph 10.8.6.

Inside:

- 12/24V transformer for auxiliary circuits and electronic board.
- Fuse holder and fuses for power and auxiliary circuits.
- Line contact maker (direct start-up up to 22 kW included), line and star/triangle contact makers (star-triangle start-up), line contact makers and reactance switching (impedance start-up).
- Star/triangle exchanger timer or reactance switching.
- Relay for signalling no phase.
- Auxiliary relays.
- Current transformer.
- Terminal boards.
- Clean contacts (max. 24V, 1A) for activating acoustic/visual alarms for no phase, pump on demand, pump running and start failure.
- Cable glands (excluding the versions to be fixed to the floor).
- Wiring diagram.



COMMAND PANEL FOR THE ELECTRIC JOCKEY PUMP

Painted metal casing (IP 55) complete with:

- General door-locking switch.
- Visual indicators for line, running, thermal shutdown.
- Manual – automatic selector – excluded.

Inside:

- Transformer for 24V auxiliary circuits.
- Fuse holder and fuses for power and auxiliary circuits.
- Line contact maker.
- Overload cut-out switch.
- Pump shut-off timer (0 ÷ 90 s).
- Terminal boards.
- Cable glands.
- Wiring diagram.

Suitable for connecting to a float switch or a minimum pressure switch for preventing dry running. An optional level control module (supplied on request) allows the connection of probes with the possibility of regulating the sensitivity according to the hardness of the water.



OPTIONS AVAILABLE ON REQUEST

CP alternative

Series of clean contacts for checking the status of the electric service pump panel, as well as the contacts already provided for signalling alarms:

- No phase
- Motor running
- Selector position MAN-AUT-0
- No start-up
- Start-up request

Series of clean contacts for checking the status of the electric jockey pump:

- Pump running
- Thermal shutdown (overload)
- No water

KV alternative

Control panel for the electric service pump with analogical voltmeter and with phase switch.

IP55 alternative

Electric service pump panel with extra IP55 protection.

COMMAND PANEL FOR DIESEL ENGINE PUMP

Painted metal casing (IP 54) complete with:

- Electronic control and management unit for the diesel engine. Display of alarms and status, battery voltage, speedometer, hour counter, alarm programming, date display, main signals and manual start button.
- Man-Auto-0 selector switch with key removable only in the auto position.
- Pair of emergency battery start buttons.
- General door-locking switch.

Inside:

- Fuse holder and fuses for power and auxiliary circuits.
- Pair of battery chargers 12Vdc/24Vdc.
- Control unit for management of diesel engine and alarms.
- Auxiliary relays.
- Power circuits for engine heaters.
- Terminal boards.
- RS232 connector for communication port.
- Cable glands.
- Wiring diagram.

The panel is supplied standard with clean alarm signal contacts (max. 1A,30Vdc/125Vac/277Vac):

- Non-automatic operating mode.
- Controller fault.
- Motor running.
- Failure to start.
- General alarm.

Single-phase 1x230V standard power supply.



Diesel engine pump panel

OPTIONS AVAILABLE ON REQUEST

IP55 alternative

Diesel engine service pump panel with additional IP55 protection.

The set is supplied already assembled, calibrated and factory tested. The set is supplied complete with an instruction manual, pump manuals and wiring diagrams for the panels.

For the sets including floor panels, the electric panels are sent together with the set in a separate pack and supplied with 5-metre long connecting cables (longer lengths available on request). The fitter is responsible for preparing the routes and installing the cables.

COMMAND PANEL DIMENSIONS

SERVICE PUMP PANEL

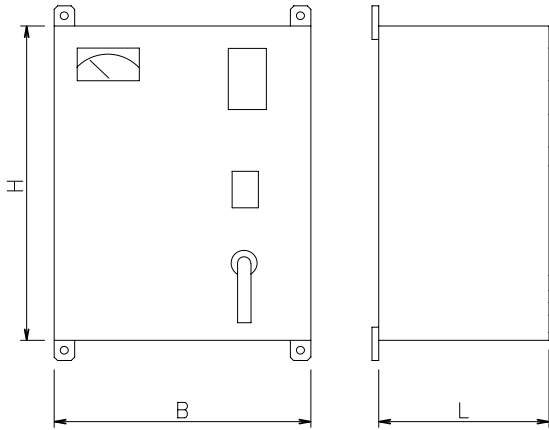

POWER (kW)	PROTECTION CLASS	B	L	H
from 0,7 to 7,5	IP54	350	160	500
from 9,2 to 22	IP54	400	200	600
from 30 to 37	IP54	500	200	700
from 45 to 55	IP54	600	250	800
from 75 to 90	IP54	600	300	1500
from 110 to 160	IP54	800	400	1700

IP55: same dimensions as standard panels IP54

qe-serv-en_d_td

Power over 55 kW: floor cupboard

QE-ELP_B_DD

JOCKEY PUMP PANEL

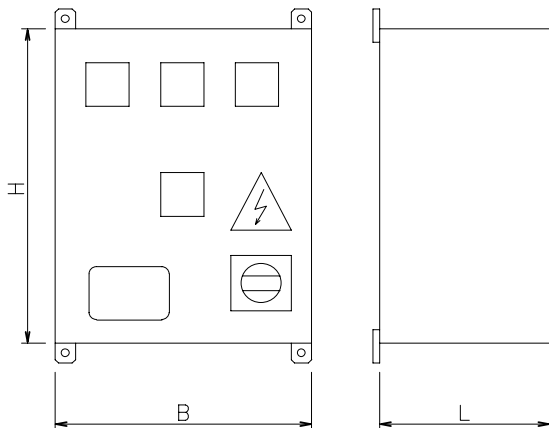

PROTECTION CLASS	B	L	H
IP54	250	160	300

IP55: same dimensions as standard panels IP54

qe-pil-en_b_td

QE-PIL_A_DD

ENGINE PUMP PANEL

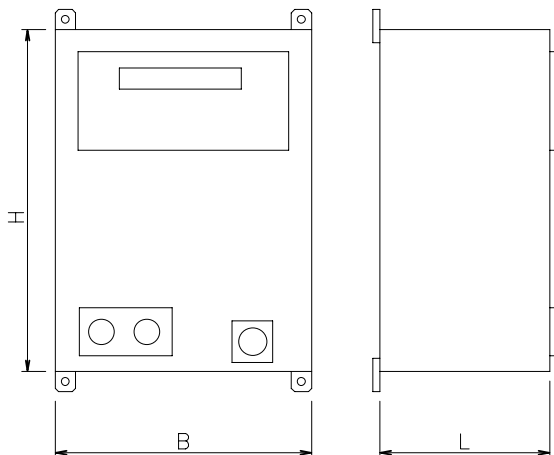

PROTECTION CLASS	B	L	H
IP54	350	200	500

IP55: same dimensions as standard panels IP54

qe-mtp12845_en_b_td

QE-MTP-EN_A_DD

* The control panels are included in the supply.

EN 12845 DIESEL ENGINE PUMP TANKS DIMENSIONS AND CAPACITY

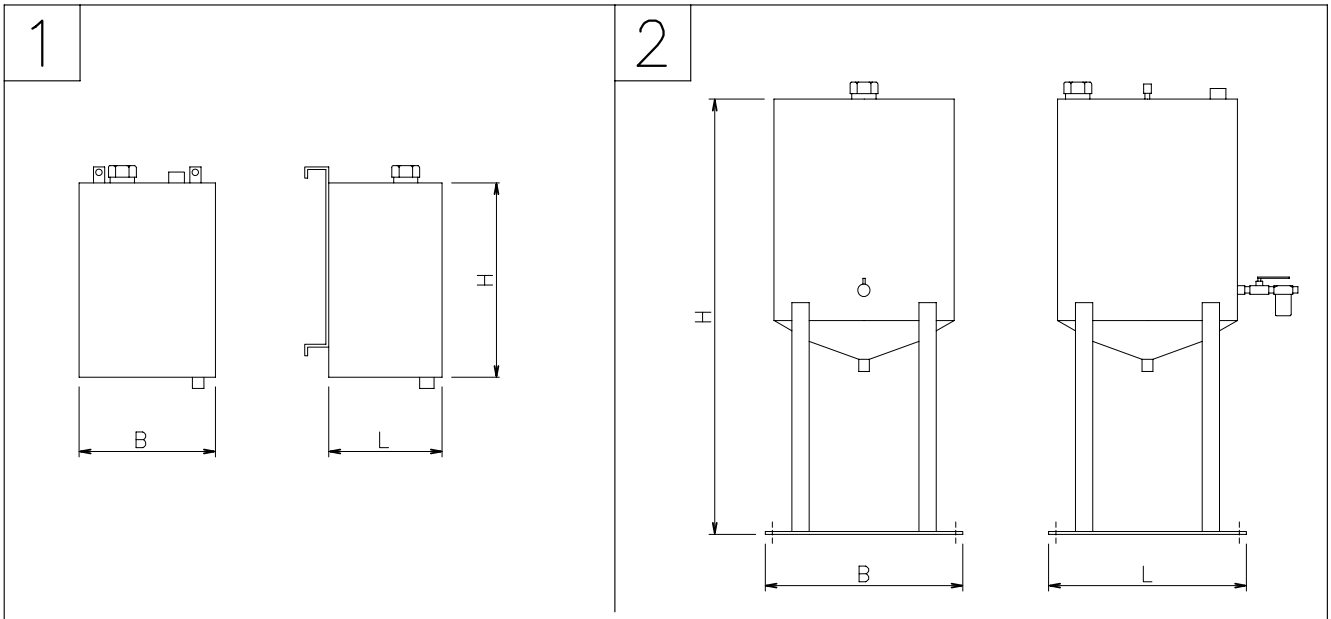

VOLUME (litres)	B	L	H	TYPE
30	260	280	550	1
65	380	330	550	1
90	420	420	1200	2
130	420	420	1450	2
190	540	550	1340	2
240	570	570	1400	2

serb-mtp-en_b_td

SERB-MTP_A_DD

Note: Special versions of additional diesel fuel tank available on request.

EN 12845 DIESEL ENGINE PUMP TANKS COMBINATIONS AND POSITIONING

PUMP	CAPACITY' (l)	D..	GEN..00D	GEN..01D	GEN..10D	GEN..11D
FHF32-125/D119	30	WALL MOUNTED	WALL MOUNTED	ON BOARD	ON BOARD	ON BOARD
FHF32-125/D136	30					
FHF32-160/D150	30					
FHF32-160/D164	30					
FHF32-200/D188	30					
FHF32-200/D204	30					
FHF40-125/D112	30	WALL MOUNTED	WALL MOUNTED	ON BOARD	ON BOARD	ON BOARD
FHF40-125/D122	30					
FHF40-125/D143	30					
FHF40-160/D159	30					
FHF40-160/D171	30					
FHF40-200/D190	30					
FHF40-200/D209	30					
FHF40-250/D218	30					
FHF40-250/D233	30					
FHF40-250/D251	30					
FHF50-125/D119	30	WALL MOUNTED	WALL MOUNTED	ON BOARD	ON BOARD	ON BOARD
FHF50-125/D130	30					
FHF50-125/D139	30					
FHF50-160/D158	30					
FHF50-160/D174	30					
FHF50-200/D197	30					
FHF50-200/D209	30					
FHF50-250/D224	30					
FHF50-250/D237	65					
FHF50-250/D250	65					
FHF65-125/D121	30	WALL MOUNTED	WALL MOUNTED	ON BOARD	ON BOARD	ON BOARD
FHF65-125/D129	30					
FHF65-125/D140	30					
FHF65-160/D161	30					
FHF65-160/D168	30					
FHF65-160/D178	30					
FHF65-200/D187	30					
FHF65-200/D198	65					
FHF65-200/D210	65					
FHF65-250/D220	65					
FHF65-250/D241	65	FLOOR-MOUNTED	FLOOR-MOUNTED	FLOOR-MOUNTED	FLOOR-MOUNTED	FLOOR-MOUNTED
FHF80-160/D163	30	WALL MOUNTED	WALL MOUNTED	ON BOARD	ON BOARD	ON BOARD
FHF80-160/D173	65					
FHF80-200/D189	65					
FHF80-200/D207	65	FLOOR-MOUNTED	FLOOR-MOUNTED	FLOOR-MOUNTED	FLOOR-MOUNTED	FLOOR-MOUNTED
FHF80-250/D225	90					
FHF80-250/D238	90					
FHF80-250/D256	130					

pos-serb-fhf12845-en_c_td

EN 12845 DIESEL ENGINE PUMP TANKS COMBINATIONS AND POSITIONING

PUMP	CAPACITY' (l)	D..	GEN..00D	GEN..01D	GEN..11D
FHF100-160/D150	30	WALL MOUNTED	WALL MOUNTED	ON BOARD	ON BOARD
FHF100-160/D165	65				
FHF100-160/D185	65				
FHF100-200/D168	65				
FHF100-200/D192	65				
FHF100-200/D203	90	FLOOR-MOUNTED	FLOOR-MOUNTED	FLOOR-MOUNTED	FLOOR-MOUNTED
FHF100-200/D213	90				
FHF100-250/D200	65	WALL MOUNTED	WALL MOUNTED	ON BOARD	ON BOARD
FHF100-250/D221	90	FLOOR-MOUNTED	FLOOR-MOUNTED	FLOOR-MOUNTED	FLOOR-MOUNTED
FHF100-250/D235	130				
FHF100-250/D254	190				
FHF100-250/D267	190				
FHF125-200/D180	65	WALL MOUNTED	WALL MOUNTED	ON BOARD	ON BOARD
FHF125-200/D206	90	FLOOR-MOUNTED	FLOOR-MOUNTED	FLOOR-MOUNTED	FLOOR-MOUNTED
FHF125-200/D216	130				
FHF125-270/D224	190				
FHF125-270/D237	190				
FHF125-270/D253	240				
FHF125-270/D266	240				

pos-serb-fhf100-12845-en_c_td

EN 12845 DIESEL ENGINE PUMP TANKS COMBINATIONS AND POSITIONING

PUMP	CAPACITY' (l)	D..	GEN..00D	GEN..01D	GEN..10D	GEN..11D					
SHF32-125/D121	30	WALL MOUNTED	WALL MOUNTED	ON BOARD	ON BOARD	ON BOARD					
SHF32-125/D136	30										
SHF32-160/D150	30										
SHF32-160/D168	30										
SHF32-200/D188	30										
SHF32-200/D204	30										
SHF32-250/D222	30										
SHF32-250/D242	30										
SHF32-250/D256	30	WALL MOUNTED	WALL MOUNTED	ON BOARD	ON BOARD	ON BOARD					
SHF40-125/D112	30										
SHF40-125/D126	30										
SHF40-125/D143	30										
SHF40-160/D159	30										
SHF40-160/D171	30										
SHF40-200/D190	30										
SHF40-200/D209	30										
SHF40-250/D218	30	WALL MOUNTED	WALL MOUNTED	ON BOARD	ON BOARD	ON BOARD					
SHF40-250/D233	30										
SHF40-250/D251	30										
SHF50-125/D119	30										
SHF50-125/D130	30										
SHF50-125/D139	30										
SHF50-160/D158	30										
SHF50-160/D174	30										
SHF50-200/D197	30	WALL MOUNTED	WALL MOUNTED	ON BOARD	ON BOARD	ON BOARD					
SHF50-200/D209	30										
SHF50-250/D224	30										
SHF50-250/D237	65										
SHF50-250/D250	65										
SHF65-160/D119	30						WALL MOUNTED	WALL MOUNTED	ON BOARD	ON BOARD	ON BOARD
SHF65-160/D129	30										
SHF65-160/D137	30										
SHF65-160/D168	30										
SHF65-160/D177	30										
SHF65-200/D192	30										
SHF65-200/D203	65										
SHF65-200/D215	65										
SHF65-250/D240	65	FLOOR-MOUNTED	FLOOR-MOUNTED	FLOOR-MOUNTED	FLOOR-MOUNTED	FLOOR-MOUNTED					
SHF65-250/D255	90										
SHF80-160/D169	30	WALL MOUNTED	WALL MOUNTED	ON BOARD	ON BOARD	ON BOARD					
SHF80-160/D177	30										
SHF80-160/D186	65										
SHF80-200/D198	65										
SHF80-200/D215	65	FLOOR-MOUNTED	FLOOR-MOUNTED	FLOOR-MOUNTED	FLOOR-MOUNTED	FLOOR-MOUNTED					
SHF80-200/D226	90										
SHF80-250/D237	90										
SHF80-250/D252	130										
SHF80-250/D270	190										

pos-serb-shf12845-en_c_td

STARTING BATTERIES FOR DIESEL ENGINE PUMP EN 12845 COMBINATIONS AND SIZES

INTRODUCTION

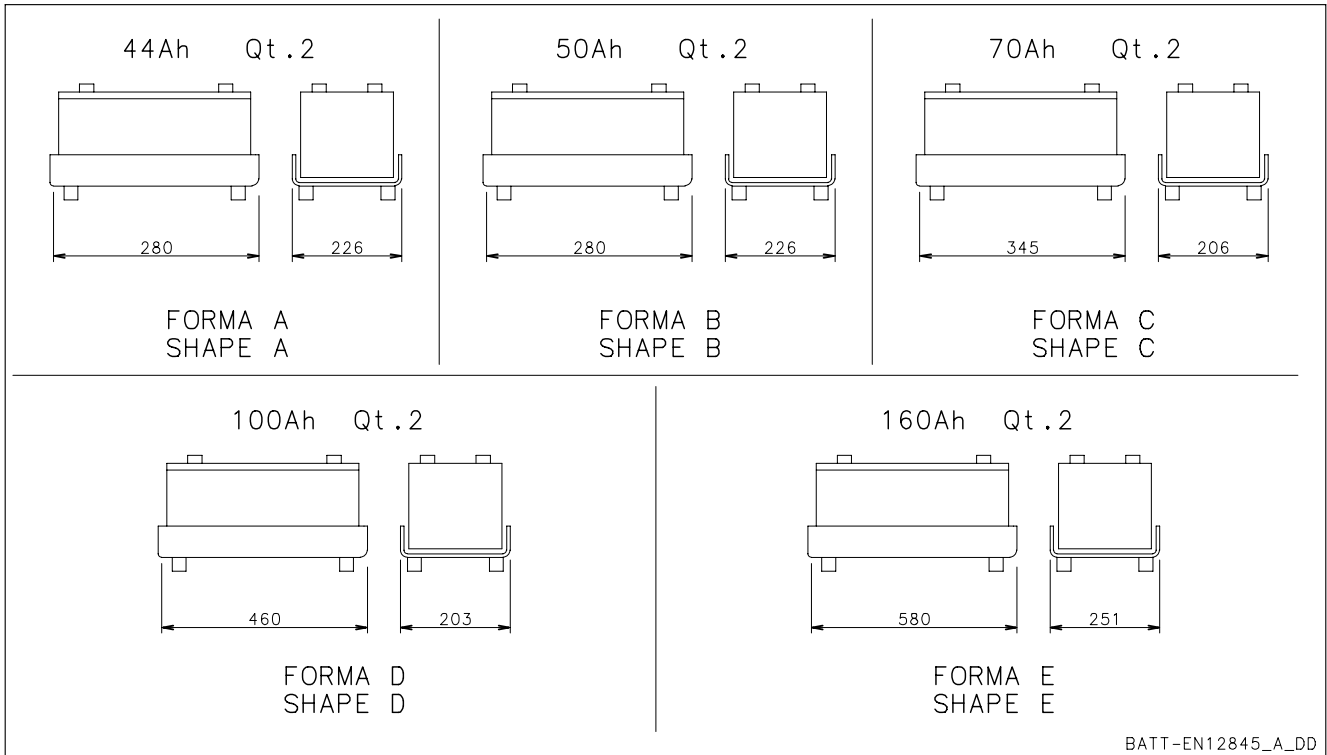

TABLE OF DIESEL ENGINE PUMP FHF 32-125 COMBINATIONS

DIESEL ENGINE PUMP TYPE DFHFE.. PUMP	BATTERY TYPE				
	A	B	C	D	E
32-125/D119	•				
32-125/D136	•				
32-160/D150	•				
32-160/D164	•				
32-200/D188	•				
32-200/D204	•				
40-125/D112	•				
40-125/D122	•				
40-125/D143	•				
40-160/D159	•				
40-160/D171	•				
40-200/D190		•			
40-200/D209		•			
40-250/D218			•		
40-250/D233				•	
40-250/D251				•	
50-125/D119	•				
50-125/D130	•				
50-125/D139	•				
50-160/D158		•			
50-160/D174		•			
50-200/D197			•		
50-200/D209				•	
50-250/D224				•	
50-250/D237					•
50-250/D250					•
65-125/D121	•				
65-125/D129		•			
65-125/D140			•		
65-160/D161			•		
65-160/D168				•	
65-160/D178				•	

DIESEL ENGINE PUMP TYPE DFHFE.. PUMP	BATTERY TYPE				
	A	B	C	D	E
65-200/D187				•	
65-200/D198					•
65-200/D210					•
65-250/D220					•
65-250/D241					•
65-250/D258					•
80-160/D163				•	
80-160/D173					•
80-200/D189					•
80-200/D207					•
80-250/D225					•
80-250/D238					•
80-250/D256					•
100-160/D150				•	
100-160/D165					•
100-160/D185					•
100-200/D168					•
100-200/D192					•
100-200/D203					•
100-200/D213					•
100-250/D200					•
100-250/D221					•
100-250/D235					•
100-250/D254					•
100-250/D267					•
125-200/D180					•
125-200/D206					•
125-200/D216					•
125-270/D224					•
125-270/D237					•
125-270/D253					•
125-270/D266					•

STARTING BATTERIES FOR DIESEL ENGINE PUMP EN 12845 TABLE OF DIESEL ENGINE PUMP SHF 32-80 COMBINATIONS

DIESEL ENGINE PUMP	BATTERY TYPE				
	A	B	C	D	E
TYPE DSHFE..					
PUMP					
32-125/D121	•				
32-125/D136	•				
32-160/D150	•				
32-160/D168	•				
32-200/D188	•				
32-200/D204	•				
32-250/D222		•			
32-250/D242		•			
32-250/D256			•		
40-125/D112	•				
40-125/D126	•				
40-125/D143	•				
40-160/D159	•				
40-160/D171	•				
40-200/D190		•			
40-200/D209		•			
40-250/D218			•		
40-250/D233				•	
40-250/D251				•	
50-125/D119	•				
50-125/D130	•				
50-125/D139	•				
50-160/D158		•			
50-160/D174		•			
50-200/D197			•		
50-200/D209			•		
50-250/D224				•	
50-250/D237					•
50-250/D250					•
65-160/D119	•				
65-160/D129		•			
65-160/D137			•		
65-160/D168			•		
65-160/D177				•	
65-200/D192				•	
65-200/D203					•
65-200/D215					•
65-250/D240					•
65-250/D255					•
80-160/D169				•	
80-160/D177				•	
80-160/D186					•
80-200/D198					•
80-200/D215					•
80-200/D226					•
80-250/D237					•
80-250/D252					•
80-250/D270					•

12845-SHF32-80_ab-en_a_tc

GEN SERIES OF BOOSTER SETS CHOICE AND SELECTION

Criteria for choosing fire-fighting sets

The correct choice of a fire-fighting set must consider various factors, including the correct sizing of the performance levels required for the system, local regulations and legislation, and especially the installation conditions relative to the installation site and whether a suction lift or a positive suction head is involved.

Choosing the type of water supply

The type of water supply and, therefore, the type of booster set to select depends on the type of system involved and is chosen according to the risk analysis performed by the designer.

There is no written rule for identifying the correct number of pumps to install.

GEN booster sets are normally designed so that every service pump can satisfy the following requirements:

100% of rated capacity with one or two pumps installed (one in service and the other in reserve).

If three pumps are installed, the capacity of the pump will be 50% of the total rated capacity and the third service pump will be considered as a reserve. In these cases, when superior or duplicated water supplies are involved, only one pump must be driven by an electric motor. This type of configuration is available on request.

Suction conditions of the booster set

The type of installation, suction lift or positive suction head, tends to affect (negatively or positively) the hydraulic performance of the pump. Remembering that EN12845 recommends against using suction lift installations, the following condition given by EN12845 must be satisfied in order to use the pump curve correctly:

$$NPSHd \geq NPSHr + 1 \text{ [m]}$$

Where: NPSHd is defined available.

NPSHr is defined requested from the pump.

As the suction check condition must be made at the max. requested flow, there can be different performance levels always respecting the NPSHd condition.

To select the booster set, consult the dedicated sections. Choice and selection. Hydraulic performance levels. Suction lift or positive suction head installation.

Performance levels of booster sets: using the tables

The tables showing the hydraulic performance levels of booster sets indicate the flow values according to the risk class for precalculated systems followed by the respective pressure value. This value does not refer to pump performance but is net of the pressure drop on the pump discharge line, to the discharge manifold flange.

This field is shown in grey and the selection must be made here, where performance levels comply with the reference standard which considers the following conditions:

- Maximum water speed in the service pump discharge piping 6 m/sec.
- $NPSHd \geq NPSHr + 1$ at the maximum flow required.
- Max. difference in level of water considered 3,2 m (for positive suction head).
- Suction pressure drops due to valves, piping, suction kit 1,5 m (limit value).

The reference suction conditions are the severest and most extreme that can occur.

The values taken in the fields that are not in grey indicate booster set performance levels in areas outside the limits of the standard and must not be used to choose the set.

GEN SERIES OF BOOSTER SETS CHOICE AND SELECTION

Method of selecting a fire-fighting booster set

Referring to EN 12845, after identifying the risk classes of the activity to protect and performing the precalculation method, the flow and head values required for the fire-fighting system can be obtained.

This data is used as follows:

1. Configuration of the booster set, choice of the number of service pumps and relative type of motor/engine (two pumps, one electric and the other driven by a diesel engine).
2. Installation conditions (e.g.. positive suction head), see performance levels for positive suction head installation.
3. Determination of service flow e.g.: 1100 l/min risk class OH3.

TYPE FHF..	RATED POWER	RISK CLASS													
		OH2n						OH3n							
		Q = DELIVERY													
ELECTRIC PUMP	PUMP	kW	l/min 0	600	700	725	850	1000	1100	1200	1300	1350	1400	1500	1600
			m3/h 0	36	42	44	51	60	66	72	78	81	84	90	96
H = TOTAL HEAD METRES COLUMN OF WATER															

4. Determining the head – e.g.: 35 m.

TYPE FHF..	RATED POWER	RISK CLASS													
		OH2n						OH3n							
		Q = DELIVERY													
ELECTRIC PUMP	PUMP	kW	l/min 0	600	700	725	850	1000	1100	1200	1300	1350	1400	1500	1600
			m3/h 0	36	42	44	51	60	66	72	78	81	84	90	96
H = TOTAL HEAD METRES COLUMN OF WATER															
50-125/22	50-125/D119	1 x 2,2	16,8	13,7	12,3	11,8	9,5	6,2	3,7	0,9					
50-125/30	50-125/D130	1 x 3	19,9	17,5	16,1	15,8	13,6	10,5	8,0	5,3	2,3				
50-125/40	50-125/D139	1 x 4	24,3	21,8	20,6	20,2	18,3	15,3	13,1	10,5	7,7	6,2	4,6		
50-160/55	50-160/D158	1 x 5,5	31,8	29,3	27,7	27,3	24,8	21,1	18,2	15,0	11,4	9,5	7,6		
50-160/75	50-160/D174	1 x 7,5	39,8	36,6	35,2	34,8	32,5	29,1	26,5	23,5	20,2	18,5	16,7	12,7	
50-200/110A	50-200/D197	1 x 11	50,6	45,6	43,4	42,8	39,5	34,8	31,2	27,3	23,1	20,9	18,6		
50-200/110	50-200/D209	1 x 11	58,0	52,6	50,5	49,9	46,7	42,1	38,6	34,7	30,4	28,1	25,7	20,7	

As can be seen, the required flow value enters the operating area in accordance with the standard, and the value of the corresponding head enters the field in grey.

From the example shown above, we can identify the **booster set** that satisfies the request. The model is pump 50-200/110 providing a head of 38,6 m.

GEN SERIES OF BOOSTER SETS CHOICE AND SELECTION - POSITIVE SUCTION HEAD INSTALLATION

EN12845 recommends always installing pumps in suction lift conditions, where possible. If this is not possible, the pumps can be installed in positive suction head conditions according to the following rules:

- The height of the minimum water level at the pump axis must not be greater than 3,2 m.
- A foot valve must be installed in the lowest point of the suction piping.
- If more than one pump is installed, the suction piping must not be interconnected.

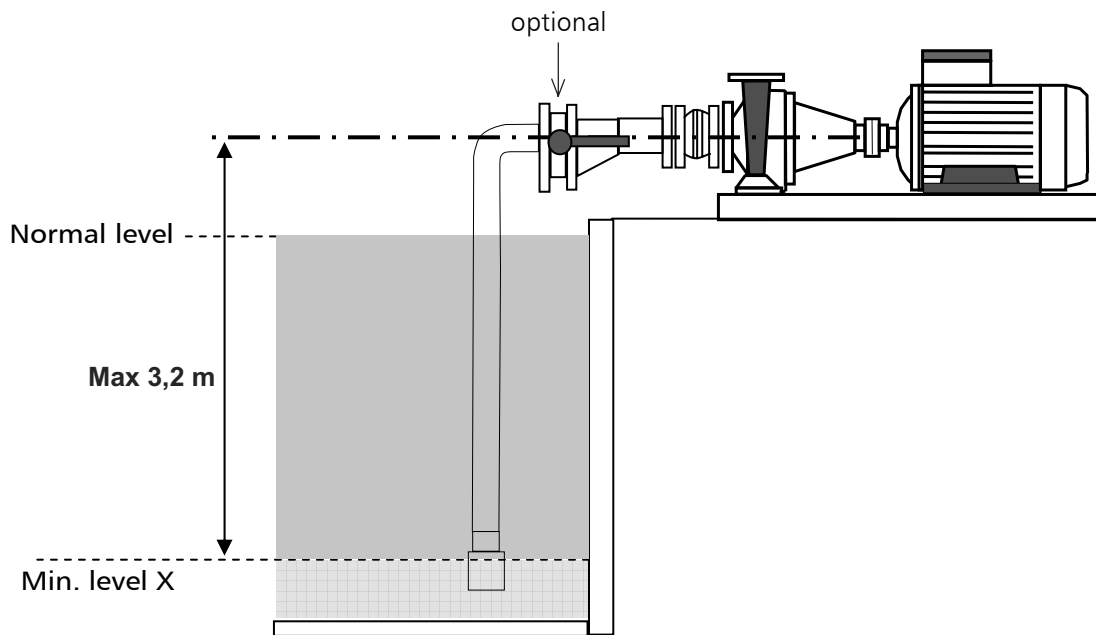

Fig. 1 positive suction head installation diagram

In accordance with EN 12845 (10.6.2.1), the suction piping, including all the valves and unions, must be designed to ensure that the NPSH available at the pump inlet exceeds the required NPSH by at least 1 m at the maximum required flow rate.

$$\text{NPSHd} \geq \text{NPSHr} + 1$$

When selecting the type of pump to use for the boosters sets, the installation conditions must be considered as these determine different pump performance levels.

An example of how to choose and check of the installation conditions is shown below:

considering the precalculation method, a suitable risk class for the system is identified, e.g.: OH3. For this risk class, the rated flow is 1100 l/min (Q_n), while the maximum requested flow is 1350 l/min (Q_m). Being in a positive suction head condition, the most difficult situation is considered, i.e.: the maximum difference in water level of 3,2 m, as indicated in the standard.

Being aware of the rated flow 1100 l/min and the pressure required for the system (e.g.: 35 m), the pump is selected according to the tables on page 44-45, making sure the performance rating lies inside the area shown in grey. The pump that satisfies the required work point is FHF50-200/110.

GEN SERIES OF BOOSTER SETS CHOICE AND SELECTION - POSITIVE SUCTION HEAD INSTALLATION

At this point, the installation conditions (positive suction head) must be checked at the **maximum required flow**.

The following values are replaced in the known relation, $NPSH_d \geq NPSH_r + 1$:

$NPSH_r$ can be deduced from the table on page 45 which in this case is 4,6 m at the maximum requested flow. After replacing the value, the following will be true (water temperature around 15°C):

$$NPSH_d = 10,33 + (-3,2) - \Sigma H_{ct}$$

Where

10,33 atmospheric pressure

3,2 geodetic difference in level

ΣH_{ct} suction pressure drop ((valves, pipes, elbows..))

The value of ΣH_{ct} considers the pressure drops of the suction kit, inclusive of vibration-proof joint, reduction cone and on-off valve (H_c), as well as the pressure drops relative to all the suction piping, foot valve, elbows, elbows, etc...

The value of H_c at the maximum required flow of the selected pump can be found in the diagram on page 81. This value is 0,16 m.

After entering it in the formula, we will have:

$$\Sigma H_{ct} = 0,16 + X$$

Where X is the pressure drop relative to all the suction piping

Hence

$NPSH_d \geq NPSH_r + 1$. After replacing this, we will have:

$$10,33 + (-3,2) - \Sigma H_{ct} = 4,6 + 1$$

$$10,33 + (-3,2) - 0,16 - X = 4,6 + 1 \text{ which gives}$$

$$X = 1,37 \text{ m}$$

Maximum value of total drops to consider on the inlet piping in order to respect the conditions of the standard. Of course, this case was deliberately put in the worst suction conditions. The designer must check and set the values in an attempt to optimise suction conditions.

GEN SERIES OF BOOSTER SETS CHOICE AND SELECTION - POSITIVE SUCTION HEAD INSTALLATION

Checking performance of the set at rated flow.

The performance of the booster set must now be checked in the installation conditions of the example used up until now.

Work point: Q_n : 1100 l/min $H = 35$ m
The selected pump is FHF50-200/110

Starting from the usual relation given by the standard, we will have:

$$NPSH_d \geq NPSH_r + 1$$

$$NPSH_d = 10,33 + (-3,2) - \sum H_{ct}$$

$NPSH_r$ can be deduced from the table on page 45 which in this case is 2,9 m **at the rated flow**.

The value of $\sum H_{ct}$ considers the pressure drops of the suction kit, inclusive of vibration-proof joint, reduction cone and on-off valve (H_c), as well as the pressure drops relative to all the suction piping, foot valve, elbows, elbows, etc...

The value of H_c at the rated required flow of the selected pump can be found in the diagram on page 81. This value is 0,12 m.

After entering it in the formula, we will have:

$$\sum H_{ct} = 0,12 + X$$

Where X is the pressure drop relative to all the suction piping

Hence

$NPSH_d \geq NPSH_r + 1$. After replacing this, we will have:

$$10,33 + (-3,2) - \sum H_{ct} = 2,9 + 1$$

$$10,33 + (-3,2) - 0,12 - X = 2,9 + 1 \text{ which gives}$$

$$X = 3,11 \text{ m}$$

Value of the total drops to consider on the suction piping

Taking the pressure value of the selected set, the value corresponds to 38,6 m at the rated flow.

Therefore, the verification of the pressure values in the above suction conditions becomes:

$$H = 38,6 - 0,12 - 3,11 = \mathbf{35,4 \text{ m}} > \mathbf{35 \text{ m}}$$
 which is the pressure required for the system

The result satisfies the performance required for the system in the installation conditions of the example.

GEN SERIES OF BOOSTER SETS CHOICE AND SELECTION - SUCTION LIFT INSTALLATION

Suction lift installation

EN12845 recommends always installing pumps in suction lift conditions, where possible, according to the following rules:

- At least two thirds of the effective capacity of the suction tank must be above the level of the pump axis.
- The pump axis must not be more than 2 m above the minimum water level in the suction tank.

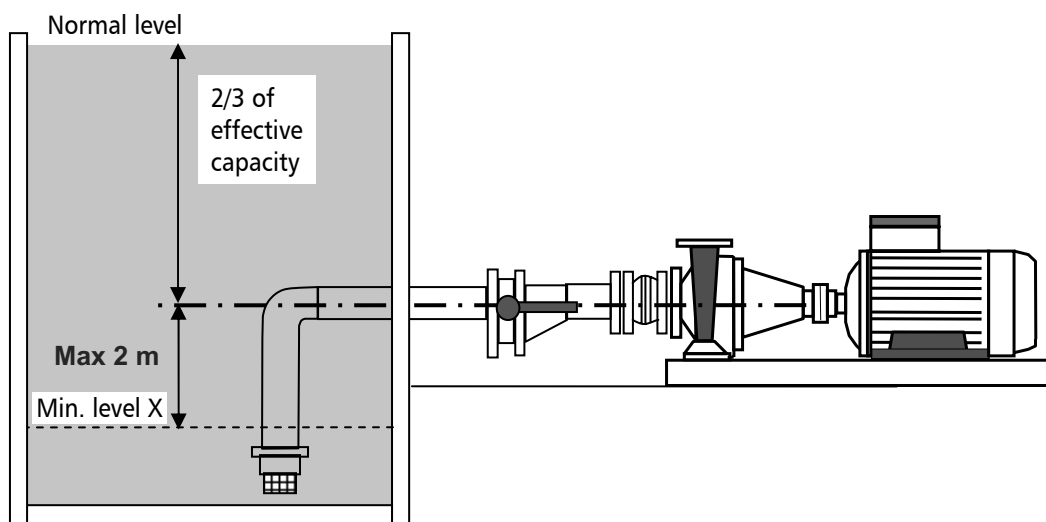

Fig. 2 suction lift installation diagram

In accordance with EN 12845 (10.6.2.1), the suction piping, including all the valves and unions, must be designed to ensure that the NPSH available at the pump inlet exceeds the required NPSH by at least 1 m at the maximum required flow rate.

$$\text{NPSHd} \geq \text{NPSHr} + 1$$

When selecting the type of pump to use for the boosters sets, the installation conditions must be considered as these determine different pump performance levels.

An example of how to choose and check of the installation conditions is shown below:

considering the precalculation method, a suitable risk class for the system is identified, e.g.: OH3. For this risk class, the rated flow is 1100 l/min (Q_n), while the maximum requested flow is 1350 l/min (Q_m). Being in the suction lift condition, a neutral situation is used in order to consider the water level on the same horizontal plane as the pump, without benefiting from any positive suction head.

GEN SERIES OF BOOSTER SETS CHOICE AND SELECTION - SUCTION LIFT INSTALLATION

Being aware of the rated flow 1100 l/min and the pressure required for the system (e.g.: 35 m), the pump is selected according to the tables on page 44-45, making sure the performance rating lies inside the area shown in grey. The pump that satisfies the required work point is FHF50-200/110.

At this point, the installation conditions (suction lift) must be checked at the maximum required flow.

The following values are replaced in the known relation, $NPSH_d \geq NPSH_r + 1$:

$NPSH_r$ can be deduced from the table on page 45 which in this case is 4,6 m at the maximum requested flow.

After replacing the value, the following will be true (water temperature around 15°C):

$$NPSH_d = 10,33 + (0) - \Sigma H_{ct}$$

Where

10,33 atmospheric pressure

0 geodetic difference in level

ΣH_{ct} suction pressure drop (valves, pipes, elbows...)

The value of ΣH_{ct} considers the pressure drops of the suction kit, inclusive of vibration-proof joint, reduction cone and on-off valve (H_c), as well as the pressure drops relative to all the suction piping, foot valve, elbows, etc...

The value of H_c at the maximum required flow of the selected pump can be found in the diagram on page 87.

This value is 0,32 m.

After entering it in the formula, we will have:

$$\Sigma H_{ct} = 0,32 + X$$

Where X is the pressure drop relative to all the suction piping

Hence

$NPSH_d \geq NPSH_r + 1$. After replacing this, we will have:

$$10,33 + (0) - \Sigma H_{ct} = 4,6 + 1$$

$$10,33 + (0) - 0,32 - X = 4,6 + 1 \quad \text{which gives}$$

$$X = 4,41 \text{ m}$$

Maximum value of total drops to consider on the inlet piping in order to respect the conditions of the standard. Of course, the case in point was deliberately tested in neutral suction conditions that neither benefit nor optimise suction.

The designer must check and set the values in an attempt to make suction conditions as efficient as possible.

GEN SERIES OF BOOSTER SETS CHOICE AND SELECTION - SUCTION LIFT INSTALLATION

Checking performance of the selected set at rated flow.

The performance of the booster set must now be checked in the installation conditions of the example used up until now.

Work point: Q_n 1100 l/min $H = 35$ m
 The selected pump is FHF50-200/110

Starting from the usual relation given by the standard, we will have:

$$NPSH_d \geq NPSH_r + 1$$

$$NPSH_d = 10,33 + (0) - \sum H_{ct}$$

$NPSH_r$ can be deduced from the table on page 45 which in this case is 2,9 m **at the rated flow**.

The value of $\sum H_{ct}$ considers the pressure drops of the suction kit, inclusive of vibration-proof joint, reduction cone and on-off valve (H_c), as well as the pressure drops relative to all the suction piping, foot valve, elbows, etc...

The value of H_c at the rated required flow of the selected pump can be found in the diagram on page 87. This value is 0,22 m.

After entering it in the formula, we will have:

$$\sum H_{ct} = 0,22 + X$$

Where X is the pressure drop relative to all the suction piping

Hence

$NPSH_d \geq NPSH_r + 1$. After replacing this, we will have:

$$10,33 + (0) - \sum H_{ct} = 2,9 + 1$$

$$10,33 + (0) - 0,22 - X = 2,9 + 1 \quad \text{which gives}$$

$$X = 6,21 \text{ m}$$

Value of the total drops to consider on the suction piping

Taking the pressure value of the selected set, the value corresponds to 38,6 m at the rated flow.

Therefore, the verification of the pressure values in the above suction conditions becomes:

$$H = 38,6 - 0,22 - 6,21 = \mathbf{32,17 \text{ m} < 35 \text{ m}}$$
 which is the pressure required for the system.

The value obtained, doesn't satisfy the performance necessary for the system, but as is evident, we have used deliberately a neutral installation condition that it doesn't give benefits to the suction. It results that installed the pump with positive suction of 3 m, we will have a pressure value of 35,17 m that it satisfied the relation.

GEN..D/FHF Series

Fire-fighting booster sets EN 12845,
electric pumps FHF series with high efficiency
motors and diesel engine pumps

50 Hz

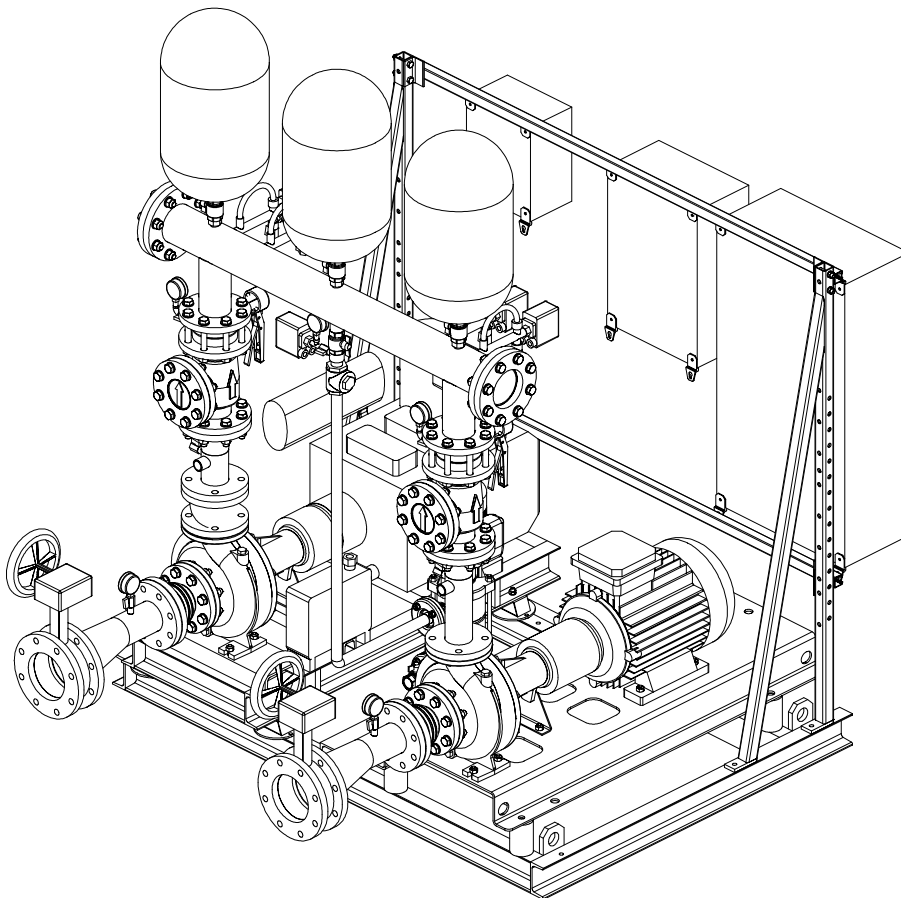

RANGE

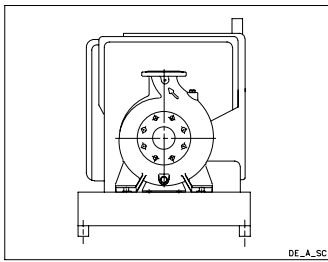

DE_A_SC

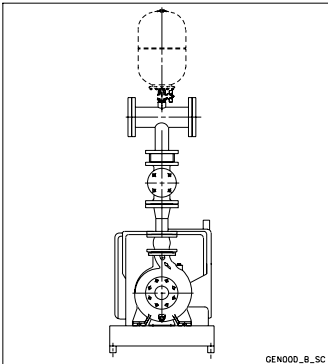

GEN000_B_SC

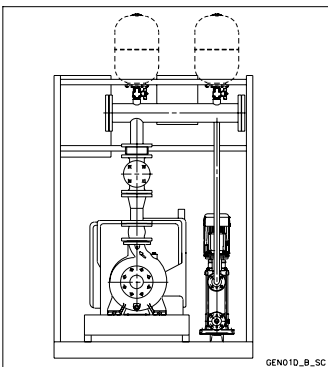

GEN010_B_SC

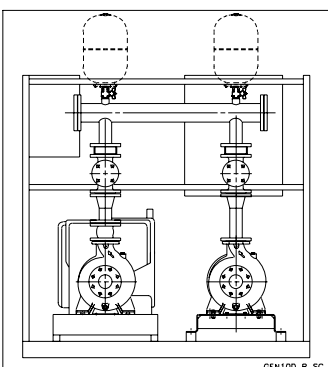

GEN100_B_SC

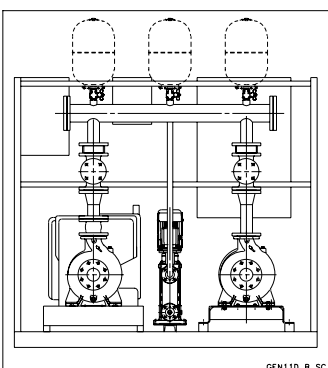

GEN110_B_SC

GEN..D/FHF RANGE

- The range of EN 12845 fire-fighting booster sets with diesel and electric service pumps and optional jockey pump to adapt to the specific needs of every application.

D.. ENGINE PUMP

- Single fire-fighting centrifugal pump in horizontal design with cast iron casing, FHF series.

Head up to 100 m.
Flow up to 650 m³/h.

GEN..00D SERIES

- Fire-fighting sets with diesel engine centrifugal service pump, in horizontal design with cast iron casing, FHF series.

Head up to 100 m.
Flow up to 650 m³/h.

GEN..01D SERIES

- Fire-fighting sets with diesel engine service pump and electric jockey pump. The centrifugal service pump has horizontal design and cast iron casing. FHF series.

Head up to 100 m.
Flow up to 650 m³/h.

GEN..10D SERIES

- Fire-fighting sets with diesel engine service pump and electric jockey pump. The centrifugal service pump has horizontal design and cast iron casing. FHF series.

Head up to 100 m.
Flow up to 1300 m³/h.

GEN..11D SERIES

- Fire-fighting sets with diesel engine service pump, electric service pump and electric jockey pump. The centrifugal service pump has horizontal design and cast iron casing. FHF series.

Head up to 100 m.
Flow up to 1300 m³/h.

GEN..D/FHF

GEN..D/FHF BOOSTER SETS SERIES HYDRAULIC PERFORMANCE TABLE AT 50 Hz (JOCKEY PUMP)

PUMP TYPE	NOMINAL POWER		Q = DELIVERY						
			l/min 0	12	20	25	30	35	40
	kW	HP	m ³ /h 0	0,7	1,2	1,5	1,8	2,1	2,4
H = TOTAL HEAD METRES COLUMN OF WATER									
1SV 02	0,37	0,5	12,2	12,2	11,5	10,7	9,5	7,9	6,0
1SV 03	0,37	0,5	18,0	18,0	17,0	15,7	13,8	11,4	8,4
1SV 04	0,37	0,5	23,7	23,5	22,1	20,4	17,9	14,6	10,6
1SV 05	0,37	0,5	29,3	28,9	27,0	24,8	21,6	17,4	12,5
1SV 06	0,37	0,5	34,8	34,2	31,7	28,9	25,0	20,0	14,0
1SV 07	0,37	0,5	40,2	39,2	36,1	32,7	28,1	22,2	15,2
1SV 08	0,55	0,75	48,1	47,9	45,2	41,8	36,8	30,4	22,4
1SV 09	0,55	0,75	53,7	53,4	50,4	46,4	40,8	33,5	24,6
1SV 10	0,55	0,75	59,4	59,0	55,5	51,0	44,7	36,6	26,6
1SV 11	0,55	0,75	65,1	64,5	60,4	55,5	48,5	39,5	28,5
1SV 12	0,75	1	73,3	73,1	69,3	64,3	57,1	47,6	35,7
1SV 13	0,75	1	79,2	78,9	74,8	69,4	61,6	51,2	38,2
1SV 15	0,75	1	90,9	90,5	85,6	79,3	70,1	58,1	43,1
1SV 17	1,1	1,5	105,2	104,9	100,0	93,1	82,6	68,6	51,2
1SV 19	1,1	1,5	117,0	116,7	111,0	103,2	91,5	75,8	56,3
1SV 22	1,1	1,5	134,6	134,1	127,4	118,1	104,4	86,1	63,5
1SV 25	1,5	2	152,6	152,4	145,5	135,4	120,0	99,1	72,7

Prestazioni conformi alle norme ISO 9906 - Annex A.

EN12845_pp_1sv-2p50-en_a_th

GEN..D/FHF 32-80 BOOSTER SETS SERIES SERVICE PUMP – JOCKEY PUMP COMBINATIONS

SERVICE PUMP		JOCKEY PUMP									
ELECTRIC PUMP	TYPE FHF..	1SV 07	1SV 08	1SV 09	1SV 10	1SV 11	1SV 12	1SV 13	1SV 15	1SV 17	1SV 19
	PUMP										
32-125/07	32-125/D119	•									
32-125/11	32-125/D136		•								
32-160/15	32-160/D150		•								
32-160/22	32-160/D164			•							
32-200/30	32-200/D188					•					
32-200/40	32-200/D204						•				
40-125/11	40-125/D112	•									
40-125/15	40-125/D122		•								
40-125/22	40-125/D143		•								
40-160/30	40-160/D159			•							
40-160/40	40-160/D171				•						
40-200/55	40-200/D190					•					
40-200/75	40-200/D209						•				
40-250/110A	40-250/D218							•			
40-250/110	40-250/D233								•		
40-250/150	40-250/D251									•	
50-125/22	50-125/D119	•									
50-125/30	50-125/D130		•								
50-125/40	50-125/D139		•								
50-160/55	50-160/D158			•							
50-160/75	50-160/D174				•						
50-200/110A	50-200/D197						•				
50-200/110	50-200/D209						•				
50-250/150	50-250/D224								•		
50-250/185	50-250/D237								•		
50-250/220	50-250/D250									•	
65-125/40	65-125/D121	•									
65-125/55	65-125/D129		•								
65-125/75	65-125/D140		•								
65-160/110A	65-160/D161			•							
65-160/110	65-160/D168				•						
65-160/150	65-160/D178				•						
65-200/150	65-200/D187					•					
65-200/185	65-200/D198						•				
65-200/220	65-200/D210						•				
65-250/220	65-250/D220							•			
65-250/300	65-250/D241								•		
65-250/370	65-250/D258									•	
80-160/150	80-160/D163			•							
80-160/185	80-160/D173				•						
80-200/220	80-200/D189					•					
80-200/300	80-200/D207						•				
80-250/370	80-250/D225								•		
80-250/450	80-250/D238								•		
80-250/550	80-250/D256									•	

GEN..D/FHF

**GEN..D/FHF 100-125 BOOSTER SETS SERIES
SERVICE PUMP – JOCKEY PUMP COMBINATIONS**

SERVICE PUMP		JOCKEY PUMP									
ELECTRIC PUMP	TYPE FHF..	1SV 07	1SV 08	1SV 09	1SV 10	1SV 11	1SV 12	1SV 13	1SV 15	1SV 17	1SV 19
	PUMP										
100-160/185	100-160/D150		•								
100-160/220	100-160/D165			•							
100-160/300	100-160/D185					•					
100-200/185	100-200/D168				•						
100-200/300	100-200/D192					•					
100-200/370	100-200/D203						•				
100-200/450	100-200/D213							•			
100-250/300	100-250/D200						•				
100-250/450	100-250/D221								•		
100-250/550	100-250/D235								•		
100-250/750	100-250/D254									•	
100-250/900	100-250/D267										•
125-200/300	125-200/D180			•							
125-200/450	125-200/D206					•					
125-200/550	125-200/D216						•				
125-270/750	125-270/D224							•			
125-270/900	125-270/D237								•		
125-270/1100	125-270/D253									•	
125-270/1320	125-270/D266										•

12845-FHF100-125_ap-en_b_tc

GEN..D/FHF

HYDRAULIC PERFORMANCE TABLE AT 50 HZ (POSITIVE SUCTION HEAD) GEN..D/FHF 32 BOOSTER SETS SERIES

TYPE FHF..	RATED POWER	RISK CLASS LHn	Q = DELIVERY												
			l/min 0	100	150	200	225	250	275	300	375	400	425	450	500
			m ³ /h 0	6	9	12	14	15	17	18	23	24	26	27	30
ELECTRIC PUMP	PUMP	kW	H = TOTAL HEAD METRES COLUMN OF WATER												
32-125/07	32-125/D119	1 x 0,75	16,9	15,6	14,1	12,1	10,9	9,6	8,1	6,6					
32-125/11	32-125/D136	1 x 1,1	21,9	20,5	19,1	17,2	16,1	14,9	13,5	12,1	7,1	5,2			
32-160/15	32-160/D150	1 x 1,5	27,3	25,6	24,0	21,8	20,5	19,0	17,4	15,6	9,5	7,2			
32-160/22	32-160/D164	1 x 2,2	34,7	33,1	31,5	29,3	27,9	26,5	24,9	23,2	17,3	15,0	12,7	10,2	
32-200/30	32-200/D188	1 x 3	44,2	41,3	39,3	36,8	35,3	33,7	32,0	30,1	23,4	20,8	18,0	15,0	
32-200/40	32-200/D204	1 x 4	54,4	51,7	49,5	46,8	45,2	43,5	41,7	39,7	33,2	30,8	28,2	25,6	20,0

Performance levels relative to set with 1 service pump running and compliant with ISO 9906 - Annex A.

12845_1pg-sp-fhf32-2p50-en_a_th

LHn = class of risk value referred to the required rated capacity (Tab.6 para 7.3.1 EN12845)

Inlet pressure drops must be deducted. Make sure that these drops, added to the difference in level (max. 3.2m), are less than 4.5m

The values shown identify performance levels according to the reference standard EN12845.

HYDRAULIC PERFORMANCE TABLE AT 50 HZ (SUCTION LIFT) GEN..D/FHF 32 BOOSTER SETS SERIES

TYPE FHF..	RATED POWER	RISK CLASS LHn	Q = DELIVERY												
			l/min 0	100	150	200	225	250	275	300	375	400	425	450	500
			m ³ /h 0	6	9	12	14	15	17	18	23	24	26	27	30
ELECTRIC PUMP	PUMP	kW	H = TOTAL HEAD METRES COLUMN OF WATER												
32-125/07	32-125/D119	1 x 0,75	16,9	15,6	14,1	12,1	10,9	9,6	8,1	6,6					
32-125/11	32-125/D136	1 x 1,1	21,9	20,5	19,1	17,2	16,1	14,9	13,5	12,1	7,1	5,2			
32-160/15	32-160/D150	1 x 1,5	27,3	25,6	24,0	21,8	20,5	19,0	17,4	15,6	9,5	7,2			
32-160/22	32-160/D164	1 x 2,2	34,7	33,1	31,5	29,3	27,9	26,5	24,9	23,2	17,3	15,0	12,7	10,2	
32-200/30	32-200/D188	1 x 3	44,2	41,3	39,3	36,8	35,3	33,7	32,0	30,1	23,4	20,8	18,0	15,0	
32-200/40	32-200/D204	1 x 4	54,4	51,7	49,5	46,8	45,2	43,5	41,7	39,7	33,2	30,8	28,2	25,6	20,0

Performance levels relative to set with 1 service pump running and compliant with ISO 9906 - Annex A.

12845_1pg-st-fhf32-2p50-en_a_th

LHn = class of risk value referred to the required rated capacity (Tab.6 para 7.3.1 EN12845)

Inlet pressure drops must be deducted. Make sure these drops are less than 4.5m

The values shown identify performance levels according to the reference standard EN12845.

NPSH REQUIRED FOR PUMP SERIES FHF 32

TYPE FHF..	RATED POWER	RISK CLASS LHn	NPSHr [METRES COLUMN OF WATER]												
			l/min 0	100	150	200	225	250	275	300	350	375	400	450	500
			m ³ /h 0	6	9	12	14	15	17	18	21	23	24	27	30
ELECTRIC PUMP	PUMP	kW													
32-125/07	32-125/D119	1 x 0,75			1,6	1,6	1,7	1,8	2,0	2,2					
32-125/11	32-125/D136	1 x 1,1			1,6	1,6	1,7	1,8	2,0	2,2	2,9	3,4	4,0		
32-160/15	32-160/D150	1 x 1,5			2,2	2,4	2,5	2,7	2,8	3,0	3,6	3,9	4,4		
32-160/22	32-160/D164	1 x 2,2			2,2	2,4	2,5	2,7	2,8	3,0	3,6	3,9	4,4	5,9	
32-200/30	32-200/D188	1 x 3			2,7	2,9	3,1	3,3	3,5	3,8	4,3	4,6	4,9	5,5	
32-200/40	32-200/D204	1 x 4			2,7	2,9	3,1	3,3	3,5	3,8	4,3	4,6	4,9	5,5	6,2

The declared NPSH values were obtained in the laboratory and refer to a single service pump

12845_1p-fhf32-2p50_NPSHr-en_a_th

LHn = class of risk value referred to the required rated capacity (Tab.6 para 7.3.1 EN12845)

Check that NPSHd ≥ NPSHr+1m is satisfied

HYDRAULIC PERFORMANCE TABLE AT 50 HZ (POSITIVE SUCTION HEAD) GEN..D/FHF 40 BOOSTER SETS SERIES

TYPE FHF..	RATED POWER	RISK CLASS OH1n	RISK CLASS															
			ELECTRIC PUMP	PUMP	kW	Q = DELIVERY												
						l/min 0	300	350	375	540	600	700	725	750	800	900	1000	1100
			m3/h 0	18	21	23	32	36	42	44	45	48	54	60	66			
			H = TOTAL HEAD METRES COLUMN OF WATER															
40-125/11	40-125/D112	1 x 1,1	13,9	11,3	10,0	9,3	3,4	0,7										
40-125/15	40-125/D122	1 x 1,5	18,0	15,3	14,0	13,3	7,4	4,7										
40-125/22	40-125/D143	1 x 2,2	25,3	21,8	20,5	19,8	14,0	11,4	6,4	5,0	3,6	0,6						
40-160/30	40-160/D159	1 x 3	31,6	28,1	26,8	26,0	19,5	16,5	10,8	9,2	7,6							
40-160/40	40-160/D171	1 x 4	38,3	35,1	33,7	32,9	26,5	23,6	18,1	16,5	15,0	11,7						
40-200/55	40-200/D190	1 x 5,5	46,4	42,7	41,2	40,4	33,1	29,7	23,3	21,5	19,6							
40-200/75	40-200/D209	1 x 7,5	57,5	53,1	51,6	50,7	43,8	40,7	34,8	33,2	31,5	28,0						
40-250/110A	40-250/D218	1 x 11	63,6	57,8	56,2	55,2	47,8	44,5	38,2	36,5	34,8	31,1						
40-250/110	40-250/D233	1 x 11	71,7	66,0	64,3	63,4	55,7	52,3	45,8	44,0	42,1	38,3						
40-250/150	40-250/D251	1 x 15	85,0	78,6	76,9	76,0	68,4	65,0	58,6	56,8	55,0	51,1	42,6					

Performance levels relative to set with 1 service pump running and compliant with ISO 9906 - Annex A.

12845_1pg-sp-fhf40-2p50-en_a_th

OHn = class of risk value referred to the required rated capacity (Tab.6 para 7.3.1 EN12845)

Inlet pressure drops must be deducted. Make sure that these drops, added to the difference in level (max. 3.2m), are less than 4.5m

The values shown identify performance levels according to the reference standard EN12845.

GEN..D/FHF

HYDRAULIC PERFORMANCE TABLE AT 50 HZ (SUCTION LIFT) GEN..D/FHF 40 BOOSTER SETS SERIES

TYPE FHF..	RATED POWER	RISK CLASS OH1n	RISK CLASS															
			ELECTRIC PUMP	PUMP	kW	Q = DELIVERY												
						l/min 0	300	350	375	540	600	700	725	750	800	900	1000	1100
			m3/h 0	18	21	23	32	36	42	44	45	48	54	60	66			
			H = TOTAL HEAD METRES COLUMN OF WATER															
40-125/11	40-125/D112	1 x 1,1	13,9	11,3	10,0	9,3	3,4	0,7										
40-125/15	40-125/D122	1 x 1,5	18,0	15,3	14,0	13,3	7,4	4,7										
40-125/22	40-125/D143	1 x 2,2	25,3	21,8	20,5	19,8	14,0	11,4	6,4	5,0	3,6	0,6						
40-160/30	40-160/D159	1 x 3	31,6	28,1	26,8	26,0	19,5	16,5	10,8	9,2	7,6							
40-160/40	40-160/D171	1 x 4	38,3	35,1	33,7	32,9	26,5	23,6	18,1	16,5	15,0	11,7						
40-200/55	40-200/D190	1 x 5,5	46,4	42,7	41,2	40,4	33,1	29,7	23,3	21,5	19,6							
40-200/75	40-200/D209	1 x 7,5	57,5	53,1	51,6	50,7	43,8	40,7	34,8	33,2	31,5	28,0						
40-250/110A	40-250/D218	1 x 11	63,6	57,8	56,2	55,2	47,8	44,5	38,2	36,5	34,8	31,1						
40-250/110	40-250/D233	1 x 11	71,7	66,0	64,3	63,4	55,7	52,3	45,8	44,0	42,1	38,3						
40-250/150	40-250/D251	1 x 15	85,0	78,6	76,9	76,0	68,4	65,0	58,6	56,8	55,0	51,1	42,6					

Performance levels relative to set with 1 service pump running and compliant with ISO 9906 - Annex A.

12845_1pg-st-fhf40-2p50-en_a_th

OHn = class of risk value referred to the required rated capacity (Tab.6 para 7.3.1 EN12845)

Inlet pressure drops must be deducted. Make sure these drops are less than 4.5m

The values shown identify performance levels according to the reference standard EN12845.

NPSH REQUIRED FOR PUMP SERIES FHF 40

TYPE FHF.. ELECTRIC PUMP		RATED POWER kW	RISK CLASS														
			OHn		OHm		Q = DELIVERY										
			l/min	0	300	350	375	540	600	700	725	750	800	900	1000	1100	
PUMP		NPSHr [METRES COLUMN OF WATER]															
		m ³ /h															
		0															
40-125/11	40-125/D112	1 x 1,1		1,8	1,9	1,9	2,4	2,7									
40-125/15	40-125/D122	1 x 1,5		1,8	1,9	1,9	2,4	2,7	3,7								
40-125/22	40-125/D143	1 x 2,2		1,8	1,9	1,9	2,4	2,7	3,7	4,1	4,6	6,3					
40-160/30	40-160/D159	1 x 3		1,9	1,9	1,9	2,4	2,9	4,1	4,5	5,0						
40-160/40	40-160/D171	1 x 4		1,9	1,9	1,9	2,4	2,9	4,1	4,5	5,0	6,2					
40-200/55	40-200/D190	1 x 5,5		2,0	2,1	2,2	2,9	3,4	4,5	4,9	5,3						
40-200/75	40-200/D209	1 x 7,5		2,0	2,1	2,2	2,9	3,4	4,5	4,9	5,3	6,3					
40-250/110A	40-250/D218	1 x 11		1,0	1,1	1,2	1,6	1,7	2,1	2,2	2,3	2,6					
40-250/110	40-250/D233	1 x 11		1,0	1,1	1,2	1,6	1,7	2,1	2,2	2,3	2,6					
40-250/150	40-250/D251	1 x 15		1,0	1,1	1,2	1,6	1,7	2,1	2,2	2,3	2,6	3,5				

The declared NPSH values were obtained in the laboratory and refer to a single service pump

12845_1p-fhf40-2p50_NPSHr-en_a_th

OHn, OHm = class of risk value referred to the required rated and maximum capacity (Tab.6 para 7.3.1 EN12845)

Check that $NPSH_d \geq NPSH_r + 1m$ is satisfied at the maximum requested capacity

HYDRAULIC PERFORMANCE TABLE AT 50 HZ (POSITIVE SUCTION HEAD) GEN..D/FHF 50 BOOSTER SETS SERIES

TYPE FHF..	RATED POWER	RISK CLASS OH _{2n} OH _{3n}	RISK CLASS												
			Q = DELIVERY												
			l/min 0	600	700	725	850	1000	1100	1200	1300	1350	1400	1500	1600
ELECTRIC PUMP	PUMP	kW	m ³ /h 0	36	42	44	51	60	66	72	78	81	84	90	96
H = TOTAL HEAD METRES COLUMN OF WATER															
50-125/22	50-125/D119	1 x 2,2	16,8	13,7	12,3	11,8	9,5	6,2	3,7	0,9					
50-125/30	50-125/D130	1 x 3	19,9	17,5	16,1	15,8	13,6	10,5	8,0	5,3	2,3				
50-125/40	50-125/D139	1 x 4	24,3	21,8	20,6	20,2	18,3	15,3	13,1	10,5	7,7	6,2	4,6		
50-160/55	50-160/D158	1 x 5,5	31,8	29,3	27,7	27,3	24,8	21,1	18,2	15,0	11,4	9,5	7,6		
50-160/75	50-160/D174	1 x 7,5	39,8	36,6	35,2	34,8	32,5	29,1	26,5	23,5	20,2	18,5	16,7	12,7	
50-200/110A	50-200/D197	1 x 11	50,6	45,6	43,4	42,8	39,5	34,8	31,2	27,3	23,1	20,9	18,6		
50-200/110	50-200/D209	1 x 11	58,0	52,6	50,5	49,9	46,7	42,1	38,6	34,7	30,4	28,1	25,7	20,7	
50-250/150	50-250/D224	1 x 15	68,1	62,8	60,9	60,4	57,3	52,6	48,8	44,4	39,4	36,7	33,8		
50-250/185	50-250/D237	1 x 18,5	76,5	71,7	70,0	69,5	66,6	62,3	58,8	54,7	50,0	47,4	44,7	38,6	
50-250/220	50-250/D250	1 x 22	86,0	81,2	79,5	79,0	76,1	71,7	68,1	64,0	59,4	56,8	54,1	48,1	41,4

Performance levels relative to set with 1 service pump running and compliant with ISO 9906 - Annex A.

12845_1pg-sp-fhf50-2p50-en_a_th

OH_n = class of risk value referred to the required rated capacity (Tab.6 para 7.3.1 EN12845)

Inlet pressure drops must be deducted. Make sure that these drops, added to the difference in level (max. 3.2m), are less than 4.5m

The values shown identify performance levels according to the reference standard EN12845.

GEN..D/FHF

HYDRAULIC PERFORMANCE TABLE AT 50 HZ (SUCTION LIFT) GEN..D/FHF 50 BOOSTER SETS SERIES

TYPE FHF..	RATED POWER	RISK CLASS OH _{2n} OH _{3n}	RISK CLASS												
			Q = DELIVERY												
			l/min 0	600	700	725	850	1000	1100	1200	1300	1350	1400	1500	1600
ELECTRIC PUMP	PUMP	kW	m ³ /h 0	36	42	44	51	60	66	72	78	81	84	90	96
H = TOTAL HEAD METRES COLUMN OF WATER															
50-125/22	50-125/D119	1 x 2,2	16,8	13,7	12,3	11,8	9,5	6,2	3,7	0,9					
50-125/30	50-125/D130	1 x 3	19,9	17,5	16,1	15,8	13,6	10,5	8,0	5,3	2,3				
50-125/40	50-125/D139	1 x 4	24,3	21,8	20,6	20,2	18,3	15,3	13,1	10,5	7,7	6,2	4,6		
50-160/55	50-160/D158	1 x 5,5	31,8	29,3	27,7	27,3	24,8	21,1	18,2	15,0	11,4	9,5	7,6		
50-160/75	50-160/D174	1 x 7,5	39,8	36,6	35,2	34,8	32,5	29,1	26,5	23,5	20,2	18,5	16,7	12,7	
50-200/110A	50-200/D197	1 x 11	50,6	45,6	43,4	42,8	39,5	34,8	31,2	27,3	23,1	20,9	18,6		
50-200/110	50-200/D209	1 x 11	58,0	52,6	50,5	49,9	46,7	42,1	38,6	34,7	30,4	28,1	25,7	20,7	
50-250/150	50-250/D224	1 x 15	68,1	62,8	60,9	60,4	57,3	52,6	48,8	44,4	39,4	36,7	33,8		
50-250/185	50-250/D237	1 x 18,5	76,5	71,7	70,0	69,5	66,6	62,3	58,8	54,7	50,0	47,4	44,7	38,6	
50-250/220	50-250/D250	1 x 22	86,0	81,3	79,5	79,0	76,1	71,7	68,2	64,1	59,5	56,9	54,2	48,2	41,6

Performance levels relative to set with 1 service pump running and compliant with ISO 9906 - Annex A.

12845_1pg-st-fhf50-2p50-en_a_th

OH_n = class of risk value referred to the required rated capacity (Tab.6 para 7.3.1 EN12845)

Inlet pressure drops must be deducted. Make sure these drops are less than 4.5m

The values shown identify performance levels according to the reference standard EN12845.

NPSH REQUIRED FOR PUMP SERIES FHF 50

TYPE FHF..	RATED POWER	RISK CLASS														
		OH														
		Q = DELIVERY														
		l/min 0	600	700	725	850	1000	1100	1200	1300	1350	1400	1500	1600		
ELECTRIC PUMP	PUMP	kW	NPSHr [METRES COLUMN OF WATER]													
			m ³ /h 0	36	42	44	51	60	66	72	78	81	84	90	96	
50-125/22	50-125/D119	1 x 2,2		2,1	2,3	2,3	2,6	3,1	3,5	3,9						
50-125/30	50-125/D130	1 x 3		2,1	2,3	2,3	2,6	3,1	3,5	3,9	4,4					
50-125/40	50-125/D139	1 x 4		2,1	2,3	2,3	2,6	3,1	3,5	3,9	4,4	4,7	5,0			
50-160/55	50-160/D158	1 x 5,5		1,9	2,1	2,2	2,5	2,9	3,2	3,6	4,2	4,6	5,1			
50-160/75	50-160/D174	1 x 7,5		1,9	2,1	2,2	2,5	2,9	3,2	3,6	4,2	4,6	5,1	6,5		
50-200/110A	50-200/D197	1 x 11		1,8	1,9	2,0	2,2	2,6	2,9	3,4	4,1	4,6	5,1			
50-200/110	50-200/D209	1 x 11		1,8	1,9	2,0	2,2	2,6	2,9	3,4	4,1	4,6	5,1	6,7		
50-250/150	50-250/D224	1 x 15		1,5	1,7	1,7	2,0	2,4	2,7	3,1	3,6	3,9	4,2			
50-250/185	50-250/D237	1 x 18,5		1,5	1,7	1,7	2,0	2,4	2,7	3,1	3,6	3,9	4,2	5,1		
50-250/220	50-250/D250	1 x 22		1,5	1,7	1,7	2,0	2,4	2,7	3,1	3,6	3,9	4,2	5,1	6,4	

The declared NPSH values were obtained in the laboratory and refer to a single service pump

12845_1p-fhf50-2p50_NPSHr-en_a_th

OHn, OHm = class of risk value referred to the required rated and maximum capacity (Tab.6 para 7.3.1 EN12845)

Check that $NPSH_d \geq NPSH_r + 1m$ is satisfied at the maximum requested capacity

HYDRAULIC PERFORMANCE TABLE AT 50 HZ (POSITIVE SUCTION HEAD) GEN..D/FHF 65 BOOSTER SETS SERIES

TYPE FHF.. ELECTRIC PUMP		RATED POWER kW	RISK CLASS											
			OH _{3n}										OH _{4n}	
			Q = DELIVERY											
PUMP	kW	l/min 0	800	900	1000	1100	1200	1350	1400	1500	1800	2000	2100	2300
		m ³ /h 0	48	54	60	66	72	81	84	90	108	120	126	138
H = TOTAL HEAD METRES COLUMN OF WATER														
65-125/40	65-125/D121	1 x 4	19,1	15,6	14,6	13,5	12,3	10,9	8,7	7,9	6,2			
65-125/55	65-125/D129	1 x 5,5	22,7	19,6	18,8	17,8	16,7	15,5	13,5	12,7	11,2	5,7		
65-125/75	65-125/D140	1 x 7,5	27,1	24,3	23,5	22,7	21,7	20,7	18,9	18,2	16,8	12,0	8,1	
65-160/110A	65-160/D161	1 x 11	32,7		29,2	28,3	27,2	26,0	23,9	23,2	21,6	15,9	11,5	9,0
65-160/110	65-160/D168	1 x 11	35,9		32,5	31,5	30,5	29,4	27,4	26,7	25,2	19,8	15,6	13,3
65-160/150	65-160/D178	1 x 15	41,9		38,9	38,1	37,1	36,1	34,2	33,6	32,2	27,2	23,2	21,1 16,3
65-200/150	65-200/D187	1 x 15	45,2		43,4	42,3	41,1	39,7	37,3	36,4	34,6	28,4	23,8	21,3
65-200/185	65-200/D198	1 x 18,5	51,6		50,2	49,2	48,2	47,0	44,9	44,1	42,4	36,5	31,8	29,2
65-200/220	65-200/D210	1 x 22	59,1		57,2	56,3	55,3	54,2	52,1	51,4	49,8	44,1	39,6	37,1 31,6
65-250/220	65-250/D220	1 x 22	62,8		60,6	59,4	58,0	56,4	53,5	52,5	50,2	42,1	35,7	32,1
65-250/300	65-250/D241	1 x 30	76,4		75,0	73,9	72,6	71,1	68,5	67,5	65,4	57,8	51,6	48,2 40,6
65-250/370	65-250/D258	1 x 37	90,8		89,9	89,0	88,0	86,7	84,5	83,7	81,8	74,8	68,8	65,4 57,7

Performance levels relative to set with 1 service pump running and compliant with ISO 9906 - Annex A.

12845_1pg-sp-fhf65-2p50-en_a_th

OH_n = class of risk value referred to the required rated capacity (Tab.6 para 7.3.1 EN12845)

Inlet pressure drops must be deducted. Make sure that these drops, added to the difference in level (max. 3.2m), are less than 4.5m

The values shown identify performance levels according to the reference standard EN12845.

GEN..D/FHF

HYDRAULIC PERFORMANCE TABLE AT 50 HZ (SUCTION LIFT) GEN..D/FHF 65 BOOSTER SETS SERIES

TYPE FHF.. ELECTRIC PUMP		RATED POWER kW	RISK CLASS											
			OH _{3n}										OH _{4n}	
			Q = DELIVERY											
PUMP	kW	l/min 0	800	900	1000	1100	1200	1350	1400	1500	1800	2000	2100	2300
		m ³ /h 0	48	54	60	66	72	81	84	90	108	120	126	138
H = TOTAL HEAD METRES COLUMN OF WATER														
65-125/40	65-125/D121	1 x 4	19,1	15,6	14,6	13,5	12,3	10,9	8,7	7,9	6,2			
65-125/55	65-125/D129	1 x 5,5	22,7	19,6	18,8	17,8	16,7	15,5	13,5	12,7	11,2	5,7		
65-125/75	65-125/D140	1 x 7,5	27,1	24,3	23,5	22,7	21,7	20,7	18,9	18,2	16,8	12,0	8,1	
65-160/110A	65-160/D161	1 x 11	32,7		29,2	28,3	27,2	26,0	23,9	23,2	21,6	15,9	11,5	9,0
65-160/110	65-160/D168	1 x 11	35,9		32,5	31,5	30,5	29,4	27,4	26,7	25,2	19,8	15,6	13,3
65-160/150	65-160/D178	1 x 15	41,9		38,9	38,1	37,1	36,1	34,2	33,6	32,2	27,2	23,2	21,1 16,3
65-200/150	65-200/D187	1 x 15	45,2		43,4	42,3	41,1	39,7	37,3	36,4	34,6	28,4	23,8	21,3
65-200/185	65-200/D198	1 x 18,5	51,6		50,2	49,2	48,2	47,0	44,9	44,1	42,4	36,5	31,8	29,2
65-200/220	65-200/D210	1 x 22	59,1		57,2	56,3	55,3	54,2	52,1	51,4	49,8	44,1	39,6	37,1 31,6
65-250/220	65-250/D220	1 x 22	62,8		60,6	59,4	58,0	56,4	53,5	52,5	50,2	42,1	35,7	32,1
65-250/300	65-250/D241	1 x 30	76,4		75,0	73,9	72,6	71,1	68,5	67,5	65,4	57,8	51,6	48,2 40,6
65-250/370	65-250/D258	1 x 37	90,8		89,9	89,0	88,0	86,7	84,5	83,7	81,8	74,8	68,8	65,4 57,7

Performance levels relative to set with 1 service pump running and compliant with ISO 9906 - Annex A.

12845_1pg-st-fhf65-2p50-en_a_th

OH_n = class of risk value referred to the required rated capacity (Tab.6 para 7.3.1 EN12845)

Inlet pressure drops must be deducted. Make sure these drops are less than 4.5m

The values shown identify performance levels according to the reference standard EN12845.

NPSH REQUIRED FOR PUMP SERIES FHF 65

TYPE FHF..		RATED POWER	RISK CLASS												
			OH3n			OH3m				OH4n			OH4m		
			Q = DELIVERY												
ELECTRIC PUMP	PUMP	kW	l/min 0	800	900	1000	1100	1200	1350	1400	1500	1800	2000	2100	2300
			m ³ /h 0	48	54	60	66	72	81	84	90	108	120	126	138
NPSHr [METRES COLUMN OF WATER]															
65-125/40	65-125/D121	1 x 4		1,0	1,2	1,3	1,6	1,9	2,4	2,6	3,1				
65-125/55	65-125/D129	1 x 5,5		1,0	1,2	1,3	1,6	1,9	2,4	2,6	3,1	5,1			
65-125/75	65-125/D140	1 x 7,5		1,0	1,2	1,3	1,6	1,9	2,4	2,6	3,1	5,1	7,0		
65-160/110A	65-160/D161	1 x 11			2,4	2,4	2,5	2,6	2,9	2,9	3,2	4,2	5,3	6,0	
65-160/110	65-160/D168	1 x 11			2,3	2,4	2,5	2,7	2,8	2,9	3,1	3,7	4,4	4,9	
65-160/150	65-160/D178	1 x 15			2,3	2,4	2,5	2,7	2,8	2,9	3,1	3,7	4,4	4,9	6,6
65-200/150	65-200/D187	1 x 15			1,8	1,9	2,0	2,1	2,3	2,4	2,6	3,4	4,5	5,3	
65-200/185	65-200/D198	1 x 18,5			1,8	1,9	2,0	2,1	2,3	2,4	2,6	3,4	4,3	4,9	
65-200/220	65-200/D210	1 x 22			1,8	1,9	2,0	2,1	2,3	2,4	2,6	3,4	4,3	4,9	6,6
65-250/220	65-250/D220	1 x 22			1,7	2,0	2,2	2,5	2,9	3,1	3,4	4,3	5,0	5,4	
65-250/300	65-250/D241	1 x 30			1,7	2,0	2,2	2,5	2,9	3,1	3,4	4,3	5,0	5,4	6,2
65-250/370	65-250/D258	1 x 37			1,7	2,0	2,2	2,5	2,9	3,1	3,4	4,3	5,0	5,4	6,2

The declared NPSH values were obtained in the laboratory and refer to a single service pump

12845_1p-fhf65-2p50_NPSHr-en_a_th

OHn, OHm = class of risk value referred to the required rated and maximum capacity (Tab.6 para 7.3.1 EN12845)

Check that $NPSH_d \geq NPSH_r + 1m$ is satisfied at the maximum requested capacity

HYDRAULIC PERFORMANCE TABLE AT 50 HZ (POSITIVE SUCTION HEAD) GEN..D/FHF 80 BOOSTER SETS SERIES

TYPE	FHF..	RATED POWER	RISK CLASS												
			OH4n						HHn						
			Q = DELIVERY												
ELECTRIC PUMP	PUMP	kW	l/min 0	1500	1650	1800	2050	2100	2200	2300	2600	3216	3500	3600	3650
			m3/h 0	90	99	108	123	126	132	138	156	193	210	216	219
H = TOTAL HEAD METRES COLUMN OF WATER															
80-160/150	80-160/D163	1 x 15	32,9	30,2	29,1	27,8	25,4	24,9	23,8	22,7	18,8	9,4	4,4		
80-160/185	80-160/D173	1 x 18,5	39,0	35,6	34,5	33,4	31,2	30,7	29,7	28,6	25,1	16,2	11,3	9,5	8,5
80-200/220	80-200/D189	1 x 22	48,0	44,7	43,4	41,8	39,0	38,3	37,0	35,6	30,9	19,2	12,8		
80-200/300	80-200/D207	1 x 30	59,9	56,9	55,8	54,4	51,9	51,3	50,1	48,9	44,7	34,2	28,5	26,4	25,3
80-250/370	80-250/D225	1 x 37	70,8	67,3	65,8	63,9	60,4	59,6	57,9	56,1	50,1	34,7	26,1		
80-250/450	80-250/D238	1 x 45	80,0	78,0	76,5	74,8	71,5	70,8	69,2	67,6	62,0	47,5	39,6	36,5	
80-250/550	80-250/D256	1 x 55	88,9	89,9	88,8	87,5	84,8	84,2	82,9	81,5	76,7	64,0	56,7	54,0	52,6

Performance levels relative to set with 1 service pump running and compliant with ISO 9906 - Annex A.

12845_1pg-sp-fhf80-2p50-en_a_th

OHn, HHn = class of risk value referred to the required rated capacity (Tab.6 para 7.3.1, Tab.7 para 7.3.2 EN12845)

Inlet pressure drops must be deducted. Make sure that these drops, added to the difference in level (max. 3.2m), are less than 4.5m

The values shown identify performance levels according to the reference standard EN12845.

GEN..D/FHF

HYDRAULIC PERFORMANCE TABLE AT 50 HZ (SUCTION LIFT) GEN..D/FHF 80 BOOSTER SETS SERIES

TYPE	FHF..	RATED POWER	RISK CLASS												
			OH4n						HHn						
			Q = DELIVERY												
ELECTRIC PUMP	PUMP	kW	l/min 0	1500	1650	1800	2050	2100	2200	2300	2600	3216	3500	3600	3650
			m3/h 0	90	99	108	123	126	132	138	156	193	210	216	219
H = TOTAL HEAD METRES COLUMN OF WATER															
80-160/150	80-160/D163	1 x 15	32,9	30,2	29,1	27,8	25,4	24,9	23,8	22,7	18,8	9,4	4,4		
80-160/185	80-160/D173	1 x 18,5	39,0	35,6	34,5	33,4	31,2	30,7	29,7	28,6	25,1	16,2	11,3	9,5	8,5
80-200/220	80-200/D189	1 x 22	48,0	44,7	43,4	41,8	39,0	38,3	37,0	35,6	30,9	19,2	12,8		
80-200/300	80-200/D207	1 x 30	59,9	56,9	55,8	54,4	51,9	51,3	50,1	48,9	44,7	34,2	28,5	26,4	25,3
80-250/370	80-250/D225	1 x 37	70,8	67,3	65,8	63,9	60,4	59,6	57,9	56,1	50,1	34,7	26,1		
80-250/450	80-250/D238	1 x 45	80,0	78,0	76,5	74,8	71,5	70,8	69,2	67,6	62,0	47,5	39,6	36,5	
80-250/550	80-250/D256	1 x 55	88,9	89,9	88,8	87,5	84,8	84,2	82,9	81,5	76,7	64,0	56,7	54,0	52,6

Performance levels relative to set with 1 service pump running and compliant with ISO 9906 - Annex A.

12845_1pg-st-fhf80-2p50-en_a_th

OHn, HHn = class of risk value referred to the required rated capacity (Tab.6 para 7.3.1, Tab.7 para 7.3.2 EN12845)

Inlet pressure drops must be deducted. Make sure these drops are less than 4.5m

The values shown identify performance levels according to the reference standard EN12845.

NPSH REQUIRED FOR PUMP SERIES FHF 80

TYPE FHF..	RATED POWER	RISK CLASS														
				OH4n		OH4m		HH1n		HH1m						
		Q = DELIVERY														
		l/min 0	1500	1650	1800	2050	2100	2200	2300	2600	3216	3500	3600	3650		
ELECTRIC PUMP	PUMP	kW	NPSHr [METRES COLUMN OF WATER]													
				m ³ /h 0	90	99	108	123	126	132	138	156	193	210	216	219
80-160/150	80-160/D163	1 x 15		3,7	3,8	3,9	4,0	4,1	4,2	4,2	4,5	5,4	6,2			
80-160/185	80-160/D173	1 x 18,5		3,7	3,8	3,9	4,0	4,1	4,2	4,2	4,5	5,4	6,2	6,5	6,8	
80-200/220	80-200/D189	1 x 22		2,8	3,0	3,1	3,3	3,4	3,5	3,6	3,9	5,1	6,3			
80-200/300	80-200/D207	1 x 30		2,8	3,0	3,1	3,3	3,4	3,5	3,6	3,9	5,1	6,3	6,9	7,3	
80-250/370	80-250/D225	1 x 37		3,0	3,1	3,3	3,6	3,6	3,8	3,9	4,4	6,0	7,4			
80-250/450	80-250/D238	1 x 45		2,4	2,6	2,7	3,0	3,1	3,2	3,3	3,8	4,9	5,5	5,7		
80-250/550	80-250/D256	1 x 55		2,4	2,6	2,7	3,0	3,1	3,2	3,3	3,8	4,9	5,5	5,7	5,8	

The declared NPSH values were obtained in the laboratory and refer to a single service pump

12845_1p-fhf80-2p50_NPSHr-en_a_th

OHn, OHm, HHn, HHm = class of risk value referred to the required rated and maximum capacity (Tab.6 para 7.3.1, Tab.7 para 7.3.2 EN12845)

Check that $NPSHd \geq NPSHr + 1m$ is satisfied at the maximum requested capacity

HYDRAULIC PERFORMANCE TABLE AT 50 HZ (POSITIVE SUCTION HEAD) GEN..D/FHF 100 BOOSTER SETS SERIES

TYPE FHF..	RATED POWER	RISK CLASS																	
		HH1n				HH2n				HH3n				HH4n					
		Q = DELIVERY																	
ELECTRIC PUMP	PUMP	kW	l/min 0	1333	1500	1667	2300	2900	3050	3216	3800	4066	4266	4333	5000	5166	5316	5500	6000
			m3/h 0	80	90	100	138	174	183	193	228	244	256	260	300	310	319	330	360
			H = TOTAL HEAD METRES COLUMN OF WATER																
100-160/185	100-160/D150	1 x 18,5	26,7	26,0	25,6	25,2	22,9	19,9	19,0	18,0	13,9	11,8	10,2	9,6	3,5	1,8			
100-160/220	100-160/D165	1 x 22	33,0	32,2	31,7	31,2	28,7	25,3	24,4	23,3	18,8	16,6	14,8	14,2	7,6	5,9	4,2	2,2	
100-160/300	100-160/D185	1 x 30	42,3	41,2	40,8	40,3	37,8	34,6	33,6	32,5	28,2	26,0	24,2	23,6	16,9	15,1	13,5	11,4	5,3
100-200/185	100-200/D168	1 x 18,5	36,3		33,5	32,7	28,6	23,5	22,0	20,3	13,5	10,1	7,4	6,4					
100-200/300	100-200/D192	1 x 30	49,0		47,5	46,9	43,7	39,5	38,3	36,8	31,0	28,0	25,5	24,7	15,5	12,9			
100-200/370	100-200/D203	1 x 37	56,0		54,6	54,0	51,0	46,9	45,8	44,4	38,7	35,8	33,4	32,6	23,7	21,2	18,9	16,0	
100-200/450	100-200/D213	1 x 45	61,0		60,0	59,5	57,1	53,6	52,6	51,4	46,3	43,7	41,5	40,7	32,3	29,9	27,7	24,8	
100-250/300	100-250/D200	1 x 30	54,6			52,1	47,7	41,8	40,0	37,9	29,3	24,8	21,2	19,9	5,9				
100-250/450	100-250/D221	1 x 45	68,8			66,9	63,5	58,7	57,2	55,4	48,1	44,2	41,0	39,9	27,2	23,6	20,3	15,9	
100-250/550	100-250/D235	1 x 55	78,5			76,9	74,0	69,8	68,5	66,9	60,2	56,6	53,6	52,6	40,6	37,2	34,0	29,8	

TYPE FHF..	RATED POWER	RISK CLASS																	
		HH4n				HH5n				HH6n									
		Q = DELIVERY																	
ELECTRIC PUMP	PUMP	kW	l/min 0	1667	2500	3800	4150	4550	4700	4800	5000	5316	5500	6000	6366	6416	6500	6716	6750
			m3/h 0	100	150	228	249	273	282	288	300	319	330	360	382	385	390	403	405
			H = TOTAL HEAD METRES COLUMN OF WATER																
100-250/750	100-250/D254	1 x 75	91,7	90,5	86,9	75,9	71,7	66,1	63,7	62,1	58,7	52,9	49,3	38,3	29,3	28,0			
100-250/900	100-250/D267	1 x 90	102,9	101,6	98,2	87,5	83,4	77,9	75,6	74,0	70,7	64,9	61,3	50,5	41,5	40,2	38,0	32,0	31,1

Performance levels relative to set with 1 service pump running and compliant with ISO 9906 - Annex A.

12845_1pg-sp-fhf100-2p50-en_b_th

HHn = class of risk value referred to the required rated capacity (Tab.7 par. 7.3.2 EN12845)

Inlet pressure drops must be deducted. Make sure these drops, added to the difference in level (max 3,2mt), are less than 4,5mt

The values shown identify performance levels according to the reference standard EN12845.

HYDRAULIC PERFORMANCE TABLE AT 50 HZ (SUCTION LIFT) GEN..D/FHF 100 BOOSTER SETS SERIES

TYPE FHF..	RATED POWER	RISK CLASS																	
		HH1n				HH2n				HH3n				HH4n					
		Q = DELIVERY																	
ELECTRIC PUMP	PUMP	kW	l/min 0	1333	1500	1667	2300	2900	3050	3216	3800	4066	4266	4333	5000	5166	5316	5500	6000
			m3/h 0	80	90	100	138	174	183	193	228	244	256	260	300	310	319	330	360
			H = TOTAL HEAD METRES COLUMN OF WATER																
100-160/185	100-160/D150	1 x 18,5	26,7	26,0	25,6	25,2	22,9	19,9	19,0	18,0	13,9	11,8	10,2	9,6	3,5	1,8			
100-160/220	100-160/D165	1 x 22	33,0	32,2	31,7	31,2	28,7	25,3	24,4	23,3	18,8	16,6	14,8	14,2	7,6	5,9	4,2	2,2	
100-160/300	100-160/D185	1 x 30	42,3	41,2	40,8	40,3	37,8	34,6	33,6	32,5	28,2	26,0	24,2	23,6	16,9	15,1	13,5	11,4	5,3
100-200/185	100-200/D168	1 x 18,5	36,3		33,5	32,7	28,6	23,5	22,0	20,3	13,5	10,1	7,4	6,4					
100-200/300	100-200/D192	1 x 30	49,0		47,5	46,9	43,7	39,5	38,3	36,8	31,0	28,0	25,5	24,7	15,5	12,9			
100-200/370	100-200/D203	1 x 37	56,0		54,6	54,0	51,0	46,9	45,8	44,4	38,7	35,8	33,4	32,6	23,7	21,2	18,9	16,0	
100-200/450	100-200/D213	1 x 45	61,0		60,0	59,5	57,1	53,6	52,6	51,4	46,3	43,7	41,5	40,7	32,3	29,9	27,7	24,8	
100-250/300	100-250/D200	1 x 30	54,6			52,1	47,7	41,8	40,0	37,9	29,3	24,8	21,2	19,9	5,9				
100-250/450	100-250/D221	1 x 45	68,8			66,9	63,5	58,7	57,2	55,4	48,1	44,2	41,0	39,9	27,2	23,6	20,3	15,9	
100-250/550	100-250/D235	1 x 55	78,5			76,9	74,0	69,8	68,5	66,9	60,2	56,6	53,6	52,6	40,6	37,2	34,0	29,8	

TYPE FHF..	RATED POWER	RISK CLASS																	
		HH4n				HH5n				HH6n									
		Q = DELIVERY																	
ELECTRIC PUMP	PUMP	kW	l/min 0	1667	2500	3800	4150	4550	4700	4800	5000	5316	5500	6000	6366	6416	6500	6716	6750
			m3/h 0	100	150	228	249	273	282	288	300	319	330	360	382	385	390	403	405
			H = TOTAL HEAD METRES COLUMN OF WATER																
100-250/750	100-250/D254	1 x 75	91,7	90,5	86,9	75,9	71,7	66,1	63,7	62,1	58,7	52,9	49,3	38,3	29,3	28,0			
100-250/900	100-250/D267	1 x 90	102,9	101,6	98,2	87,5	83,4	77,9	75,6	74,0	70,7	64,9	61,3	50,5	41,5	40,2	38,0	32,0	31,1

Performance levels relative to set with 1 service pump running and compliant with ISO 9906 - Annex A.

12845_1pg-st-fhf100-2p50-en_b_th

HHn = class of risk value referred to the required rated capacity (Tab.7 par. 7.3.2 EN12845)

Inlet pressure drops must be deducted. Make sure these drops are less than 4,5mt

The values shown identify performance levels according to the reference standard EN12845.

NPSH REQUIRED FOR PUMP SERIES FHF 100

TYPE		RATED	RISK CLASS																	
FHF..	POWER		HH1n	HH2n	HH3n	HH1m	HH4n	HH2m	HH3m	HH4m										
ELECTRIC PUMP	PUMP	kW	Q = DELIVERY																	
			V/min 0	1333	1500	1667	2300	2900	3050	3216	3800	4066	4266	4333	5000	5166	5316	5500	6000	
			m3/h 0	80	90	100	138	174	183	193	228	244	256	260	300	310	319	330	360	
			NPSHr [METRES COLUMN OF WATER]																	
100-160/185	100-160/D150	1 x 18,5		6,3	6,4	6,6	7,3	8,0	8,2	8,4	9,2	9,5	9,8	9,9	11,0	11,4				
100-160/220	100-160/D165	1 x 22		5,0	5,2	5,4	6,2	6,9	7,0	7,2	7,9	8,3	8,5	8,6	9,6	9,9	10,3	10,7		
100-160/300	100-160/D185	1 x 30		5,0	5,2	5,4	6,2	6,9	7,0	7,2	7,9	8,3	8,5	8,6	9,6	9,9	10,3	10,7	12,8	
100-200/185	100-200/D168	1 x 18,5			4,2	4,2	4,6	5,6	6,0	6,5	9,2	11,1	12,8	13,5						
100-200/300	100-200/D192	1 x 30			3,1	3,1	3,3	3,5	3,6	3,7	4,2	4,6	4,9	5,1	7,0	7,7				
100-200/370	100-200/D203	1 x 37			3,1	3,1	3,3	3,5	3,6	3,7	4,2	4,6	4,9	5,1	7,0	7,7	8,4	9,5		
100-200/450	100-200/D213	1 x 45			3,1	3,1	3,3	3,5	3,6	3,7	4,2	4,6	4,9	5,1	7,0	7,7	8,4	9,5		
100-250/300	100-250/D200	1 x 30				4,7	5,0	5,3	5,4	5,4	5,7	5,8	5,9	6,0	6,3					
100-250/450	100-250/D221	1 x 45				4,6	4,7	4,7	4,8	4,8	4,8	4,9	4,9	4,9	5,1	5,2	5,2	5,3		
100-250/550	100-250/D235	1 x 55				4,6	4,7	4,7	4,8	4,8	4,8	4,9	4,9	4,9	5,1	5,2	5,2	5,3		

TYPE		RATED	RISK CLASS																	
FHF..	POWER		HH4n	HH5n	HH6n	HH4m	HH5m						HH6m							
ELECTRIC PUMP	PUMP	kW	Q = DELIVERY																	
			V/min 0	1667	2500	3800	4150	4550	4700	4800	5000	5316	5500	6000	6366	6416	6500	6716	6750	
			m3/h 0	100	150	228	249	273	282	288	300	319	330	360	382	385	390	403	405	
			NPSHr [METRES COLUMN OF WATER]																	
100-250/750	100-250/D254	1 x 75		4,6	4,7	4,8	4,9	5,0	5,0	5,0	5,1	5,2	5,3	5,8	6,6	6,7				
100-250/900	100-250/D267	1 x 90		4,6	4,7	4,8	4,9	5,0	5,0	5,0	5,1	5,2	5,3	5,8	6,6	6,7	6,9	7,8	7,9	

The declared NPSH values were obtained in the laboratory and refer to a single service pump

12845_1p-fhf100-2p50_NPSHr-en_a_th

HHn, HHm = class of risk value referred to the required rated and maximum capacity (Tab.7 para 7.3.2 EN12845)

Check that $NPSH_d \geq NPSH_r + 1m$ is satisfied at the maximum requested capacity

GEN..D/FHF

HYDRAULIC PERFORMANCE TABLE AT 50 HZ (POSITIVE SUCTION HEAD) GEN..D/FHF 125 BOOSTER SETS SERIES

TYPE	FHF..	RATED POWER	RISK CLASS																			
			HH6n					HH7n					HH8n					HH9n		HH10n		
			Q = DELIVERY																			
ELECTRIC PUMP	PUMP	kW	l/min	2000	2500	4800	4850	5700	6000	6400	6716	6783	7500	7983	8400	8667	8966	9333	9583	10000	10333	10833
			m ³ /h	120	150	288	291	342	360	384	403	407	450	479	504	520	538	560	575	600	620	650
H = TOTAL HEAD METRES COLUMN OF WATER																						
125-200/300	125-200/D180	1 x 30	32,8	29,8	28,4	19,8	19,6	15,8	14,4	12,6	11,2	10,9	7,6									
125-200/450	125-200/D206	1 x 45	47,2	44,8	43,5	34,8	34,6	30,3	28,6	26,4	24,5	24,1	19,7	16,6	13,9	12,1						
125-200/550	125-200/D216	1 x 55	57,4	55,1	54,0	45,6	45,4	41,0	39,3	36,8	34,8	34,3	29,3	25,6	22,3	20,0	17,4	14,1				
125-270/750	125-270/D224	1 x 75	65,1		63,7	56,0	55,8	51,5	49,8	47,3	45,3	44,8	39,8	36,1	32,7	30,5	27,9	24,6	22,3			
125-270/900	125-270/D237	1 x 90	75,3		73,6	67,0	66,8	62,8	61,1	58,8	56,8	56,3	51,2	47,4	43,8	41,4	38,5	34,8	32,2	27,5		
125-270/1100	125-270/D253	1 x 110	88,2		85,4	79,2	79,0	75,1	73,5	71,2	69,2	68,8	63,5	59,5	55,7	53,0	49,9	45,8	42,8	37,6	33,1	
125-270/1320	125-270/D266	1 x 132	97,5		94,8	88,6	88,4	84,7	83,2	81,1	79,2	78,8	74,0	70,3	66,8	64,5	61,7	58,0	55,4	50,7	46,8	

Performance levels relative to set with 1 service pump running and compliant with ISO 9906 - Annex A.

12845_1pg-sp-fhf125-2p50-en_b_th

HHn = class of risk value referred to the required rated capacity (Tab.7 par. 7.3.2 EN12845)

Inlet pressure drops must be deducted. Make sure these drops, added to the difference in level (max 3,2mt), are less than 4,5mt

The values shown identify performance levels according to the reference standard EN12845.

HYDRAULIC PERFORMANCE TABLE AT 50 HZ (SUCTION LIFT) GEN..D/FHF 125 BOOSTER SETS SERIES

TYPE	FHF..	RATED POWER	RISK CLASS																			
			HH6n					HH7n					HH8n					HH9n		HH10n		
			Q = DELIVERY																			
ELECTRIC PUMP	PUMP	kW	l/min	2000	2500	4800	4850	5700	6000	6400	6716	6783	7500	7983	8400	8667	8966	9333	9583	10000	10333	10833
			m ³ /h	120	150	288	291	342	360	384	403	407	450	479	504	520	538	560	575	600	620	650
H = TOTAL HEAD METRES COLUMN OF WATER																						
125-200/300	125-200/D180	1 x 30	32,8	29,8	28,4	19,8	19,6	15,8	14,4	12,6	11,2	10,9	7,6									
125-200/450	125-200/D206	1 x 45	47,2	44,8	43,5	34,8	34,6	30,3	28,6	26,4	24,5	24,1	19,7	16,6	13,9	12,1						
125-200/550	125-200/D216	1 x 55	57,4	55,1	54,0	45,6	45,4	41,0	39,3	36,8	34,8	34,3	29,3	25,6	22,3	20,0	17,4	14,1				
125-270/750	125-270/D224	1 x 75	65,1		63,7	56,0	55,8	51,5	49,8	47,3	45,3	44,8	39,8	36,1	32,7	30,5	27,9	24,6	22,3			
125-270/900	125-270/D237	1 x 90	75,3		73,6	67,0	66,8	62,8	61,1	58,8	56,8	56,3	51,2	47,4	43,8	41,4	38,5	34,8	32,2	27,5		
125-270/1100	125-270/D253	1 x 110	88,2		85,4	79,2	79,0	75,1	73,5	71,2	69,2	68,8	63,5	59,5	55,7	53,0	49,9	45,8	42,8	37,6	33,1	
125-270/1320	125-270/D266	1 x 132	97,5		94,8	88,6	88,4	84,7	83,2	81,1	79,2	78,8	74,0	70,3	66,8	64,5	61,7	58,0	55,4	50,7	46,8	

Performance levels relative to set with 1 service pump running and compliant with ISO 9906 - Annex A.

12845_1pg-st-fhf125-2p50-en_b_th

HHn = class of risk value referred to the required rated capacity (Tab.7 par. 7.3.2 EN12845)

Inlet pressure drops must be deducted. Make sure these drops are less than 4,5mt

The values shown identify performance levels according to the reference standard EN12845.

NPSH REQUIRED FOR PUMP SERIES FHF 125

TYPE	FHF..	RATED POWER	RISK CLASS																			
			HH6n					HH7n					HH8n					HH9n		HH10n		
			Q = DELIVERY																			
ELECTRIC PUMP	PUMP	kW	l/min	2000	2500	4800	4850	5700	6000	6400	6716	6783	7500	7983	8400	8667	8966	9333	9583	10000	10333	10833
			m ³ /h	120	150	288	291	342	360	384	403	407	450	479	504	520	538	560	575	600	620	650
NPSHr [METRES COLUMN OF WATER]																						
125-200/300	125-200/D180	1 x 30		6,5	6,8	8,5	8,5	9,1	9,3	9,6	9,9	9,9	10,4									
125-200/450	125-200/D206	1 x 45		6,1	6,2	7,1	7,1	7,6	7,7	8,0	8,3	8,3	8,9	9,5	10,0	10,4						
125-200/550	125-200/D216	1 x 55		6,1	6,2	7,1	7,1	7,6	7,7	8,0	8,3	8,3	8,9	9,5	10,0	10,4	10,8	11,5				
125-270/750	125-270/D224	1 x 75			7,8	8,3	8,3	8,5	8,6	8,7	8,8	8,9	9,3	9,7	10,1	10,5	11,1	11,9	12,7			
125-270/900	125-270/D237	1 x 90			6,0	6,9	6,9	7,2	7,3	7,5	7,7	7,7	8,1	8,4	8,8	9,0	9,4	9,9	10,4	11,4		
125-270/1100	125-270/D253	1 x 110			6,0	6,9	6,9	7,2	7,3	7,5	7,7	7,7	8,1	8,4	8,8	9,0	9,4	9,9	10,4	11,4	12,5	
125-270/1320	125-270/D266	1 x 132			6,0	6,9	6,9	7,2	7,3	7,5	7,7	7,7	8,1	8,4	8,8	9,0	9,4	9,9	10,4	11,4	12,5	

The declared NPSH values were obtained in the laboratory and refer to a single service pump

12845_1pg-fhf125-2p50_NPSHr-en_a_th

HHn, HHm = class of risk value referred to the required rated and maximum capacity (Tab.7 para 7.3.2 EN12845)

Check that NPSHd ≥ NPSHr+1m is satisfied at the maximum requested capacity

GEN..D/FHF 100-125 BOOSTER SETS ELECTRICAL DATA TABLE AT 50 Hz

SERVICE PUMP 3 X 400 V				ELECTRIC JOCKEY PUMP				CURRENT (*) ABSORBED SET			
TYPE FHF..		NOMINAL POWER		TYPE	Pn kW	1x230V	3x400V	1 x 230V		3x400	
ELECTRIC PUMP	PUMP	Pn kW	In A			In A	In A	GEN..00D A	GEN..01D A	GEN..10D A	GEN..11D A
32-125/07	32-125/D119	0,75	1,76	1SV 07	0,37	2,82	1,35	3	5,8	4,8	6,1
32-125/11	32-125/D136	1,1	2,36	1SV 08	0,55	3,88	1,48	3	6,9	5,4	6,8
32-160/15	32-160/D150	1,5	3,02	1SV 08	0,55	3,88	1,48	3	6,9	6,0	7,5
32-160/22	32-160/D164	2,2	4,64	1SV 09	0,55	3,88	1,48	3	6,9	7,6	9,1
32-200/30	32-200/D188	3	5,91	1SV 11	0,55	3,88	1,48	3	6,9	8,9	10,4
32-200/40	32-200/D204	4	7,50	1SV 12	0,75	4,88	1,76	3	7,9	10,5	12,3
40-125/11	40-125/D112	1,1	2,36	1SV 07	0,37	2,82	1,35	3	5,8	5,4	6,7
40-125/15	40-125/D122	1,5	3,02	1SV 08	0,55	3,88	1,48	3	6,9	6,0	7,5
40-125/22	40-125/D143	2,2	4,64	1SV 08	0,55	3,88	1,48	3	6,9	7,6	9,1
40-160/30	40-160/D159	3	5,91	1SV 09	0,55	3,88	1,48	3	6,9	8,9	10,4
40-160/40	40-160/D171	4	7,50	1SV 10	0,55	3,88	1,48	3	6,9	10,5	12,0
40-200/55	40-200/D190	5,5	11,00	1SV 11	0,55	3,88	1,48	3	6,9	14,0	15,5
40-200/75	40-200/D209	7,5	14,30	1SV 12	0,75	4,88	1,76	3	7,9	17,3	19,1
40-250/110A	40-250/D218	11	19,80	1SV 13	0,75	4,88	1,76	3	7,9	22,8	24,6
40-250/110	40-250/D233	11	19,80	1SV 15	0,75	4,88	1,76	3	7,9	22,8	24,6
40-250/150	40-250/D251	15	26,20	1SV 17	1,1	6,77	2,36	3	9,8	29,2	31,6
50-125/22	50-125/D119	2,2	4,64	1SV 07	0,37	2,82	1,35	3	5,8	7,6	9,0
50-125/30	50-125/D130	3	5,91	1SV 08	0,55	3,88	1,48	3	6,9	8,9	10,4
50-125/40	50-125/D139	4	7,50	1SV 08	0,55	3,88	1,48	3	6,9	10,5	12,0
50-160/55	50-160/D158	5,5	11,00	1SV 09	0,55	3,88	1,48	3	6,9	14,0	15,5
50-160/75	50-160/D174	7,5	14,30	1SV 10	0,55	3,88	1,48	3	6,9	17,3	18,8
50-200/110A	50-200/D197	11	19,80	1SV 12	0,75	4,88	1,76	3	7,9	22,8	24,6
50-200/110	50-200/D209	11	19,80	1SV 12	0,75	4,88	1,76	3	7,9	22,8	24,6
50-250/150	50-250/D224	15	26,20	1SV 15	0,75	4,88	1,76	3	7,9	29,2	31,0
50-250/185	50-250/D237	18,5	32,90	1SV 15	0,75	4,88	1,76	3	7,9	35,9	37,7
50-250/220	50-250/D250	22	39,10	1SV 17	1,1	6,77	2,36	3	9,8	42,1	44,5
65-125/40	65-125/D121	4	7,50	1SV 07	0,37	2,82	1,35	3	5,8	10,5	11,9
65-125/55	65-125/D129	5,5	11,00	1SV 08	0,55	3,88	1,48	3	6,9	14,0	15,5
65-125/75	65-125/D140	7,5	14,30	1SV 08	0,55	3,88	1,48	3	6,9	17,3	18,8
65-160/110A	65-160/D161	11	19,80	1SV 09	0,55	3,88	1,48	3	6,9	22,8	24,3
65-160/110	65-160/D168	11	19,80	1SV 10	0,55	3,88	1,48	3	6,9	22,8	24,3
65-160/150	65-160/D178	15	26,20	1SV 10	0,55	3,88	1,48	3	6,9	29,2	30,7
65-200/150	65-200/D187	15	26,20	1SV 11	0,55	3,88	1,48	3	6,9	29,2	30,7
65-200/185	65-200/D198	18,5	32,90	1SV 12	0,75	4,88	1,76	3	7,9	35,9	37,7
65-200/220	65-200/D210	22	39,10	1SV 12	0,75	4,88	1,76	3	7,9	42,1	43,9
65-250/220	65-250/D220	22	39,10	1SV 13	0,75	4,88	1,76	3	7,9	42,1	43,9
65-250/300	65-250/D241	30	53,60	1SV 15	0,75	4,88	1,76	3	7,9	56,6	58,4
65-250/370	65-250/D258	37	65,80	1SV 17	1,1	6,77	2,36	3	9,8	68,8	71,2
80-160/150	80-160/D163	15	26,20	1SV 09	0,55	3,88	1,48	3	6,9	29,2	30,7
80-160/185	80-160/D173	18,5	32,90	1SV 10	0,55	3,88	1,48	3	6,9	35,9	37,4
80-200/220	80-200/D189	22	39,10	1SV 11	0,55	3,88	1,48	3	6,9	42,1	43,6
80-200/300	80-200/D207	30	53,60	1SV 12	0,75	4,88	1,76	3	7,9	56,6	58,4
80-250/370	80-250/D225	37	65,80	1SV 15	0,75	4,88	1,76	3	7,9	68,8	70,6
80-250/450	80-250/D238	45	78,00	1SV 15	0,75	4,88	1,76	3	7,9	81,0	82,8
80-250/550	80-250/D256	55	95,00	1SV 17	1,1	6,77	2,36	3	9,8	98,0	100,4

ENMTP-FHF_2p50-en_d_te

(*) The current indicated is the maximum current absorbed.

At the set 3x400V three-phase power supply GEN..10D and GEN..11D to add the control panel current of the engine pump (GEN..0D) 1x230V
The sets GEN..01D have the electric jockey pump 1x230V single-phase power supply.

GEN..D/FHF

GEN..D/FHF 100-125 BOOSTER SETS ELECTRICAL DATA TABLE AT 50 Hz

SERVICE PUMP 3 X 400 V				ELECTRIC JOCKEY PUMP				CURRENT (*) ABSORBED SET			
TYPE FHF..		NOMINAL POWER		TYPE	Pn kW	1x230V	3x400V	1 x 230V		3x400	
ELECTRIC PUMP	PUMP	Pn kW	In A			In A	In A	GEN..00D A	GEN..01D A	GEN..10D A	GEN..11D A
100-160/185	100-160/D150	18,5	32,9	1SV 08	0,55	3,88	1,48	3	6,9	35,9	37,4
100-160/220	100-160/D165	22	39,1	1SV 09	0,55	3,88	1,48	3	6,9	42,1	43,6
100-160/300	100-160/D185	30	53,6	1SV 11	0,55	3,88	1,48	3	6,9	56,6	58,1
100-200/185	100-200/D168	18,5	32,9	1SV 10	0,55	3,88	1,48	3	6,9	35,9	37,4
100-200/300	100-200/D192	30	53,6	1SV 11	0,55	3,88	1,48	3	6,9	56,6	58,1
100-200/370	100-200/D203	37	65,8	1SV 12	0,75	4,88	1,76	3	7,9	68,8	70,6
100-200/450	100-200/D213	45	78,0	1SV 13	0,75	4,88	1,76	3	7,9	81,0	82,8
100-250/300	100-250/D200	30	53,6	1SV 12	0,75	4,88	1,76	3	7,9	56,6	58,4
100-250/450	100-250/D221	45	78,0	1SV 15	0,75	4,88	1,76	3	7,9	81,0	82,8
100-250/550	100-250/D235	55	95,0	1SV 15	0,75	4,88	1,76	3	7,9	98,0	99,8
100-250/750	100-250/D254	75	129,0	1SV 17	1,1	6,77	2,36	3	9,8	132,0	134,4
100-250/900	100-250/D267	90	154,0	1SV 19	1,1	6,77	2,36	3	9,8	157,0	159,4
125-200/300	125-200/D180	30	53,6	1SV 09	0,55	3,88	1,48	3	6,9	56,6	58,1
125-200/450	125-200/D206	45	78,0	1SV 11	0,55	3,88	1,48	3	6,9	81,0	82,5
125-200/550	125-200/D216	55	95,0	1SV 12	0,75	4,88	1,76	3	7,9	98,0	99,8
125-270/750	125-270/D224	75	129,0	1SV 13	0,75	4,88	1,76	3	7,9	132,0	133,8
125-270/900	125-270/D237	90	154,0	1SV 15	0,75	4,88	1,76	3	7,9	157,0	158,8
125-270/1100	125-270/D253	110	188,0	1SV 17	1,1	6,77	2,36	4,5	11,3	192,5	194,9
125-270/1320	125-270/D266	132	223,0	1SV 19	1,1	6,77	2,36	4,5	11,3	227,5	229,9

ENMTP-FHF100-en_2p50_d_te

(*) The current indicated is the maximum current absorbed.

At the set 3x400V three-phase power supply GEN..10D and GEN..11D to add the control panel current of the engine pump (GEN..0D) 1x230V
The sets GEN..01D have the electric jockey pump 1x230V single-phase power supply.

**Fire-fighting
booster sets
EN 12845**

MARKET SECTORS

CIVIL, INDUSTRIAL

APPLICATIONS

- Fixed fire-fighting systems.
Automatic Sprinkler systems.

**DFHF
Series**

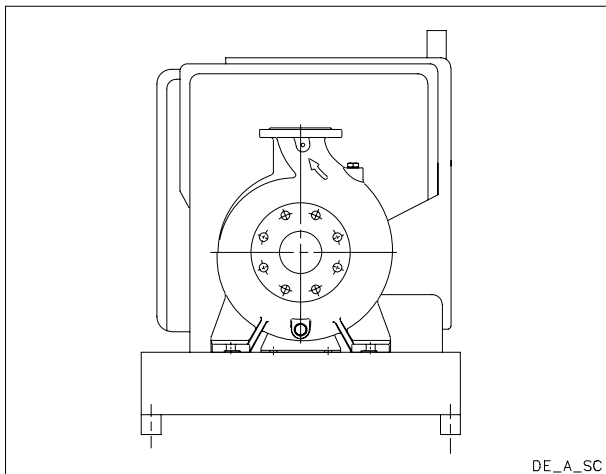

SPECIFICATIONS

- **Flow** up to 650 m³/h.
- **Head** up to 100 m.
- Panel supply power voltage:
1 x 230V ± 10%.
- Frequency: 50 Hz.
- Voltage for controls outside panel:
12 - 24 Vac.
- Protection grade:
- electric panel: IP54.
- Electric pumps maximum power
132 kW.
- Diesel engine with battery start.
- **Diesel engine service pump
in horizontal design:**
- FHF series.
- Maximum running pressure: 12 bar.

**DFHF 32-80 DIESEL ENGINE PUMP SERIES
FIRE-FIGHTING EN 12845**

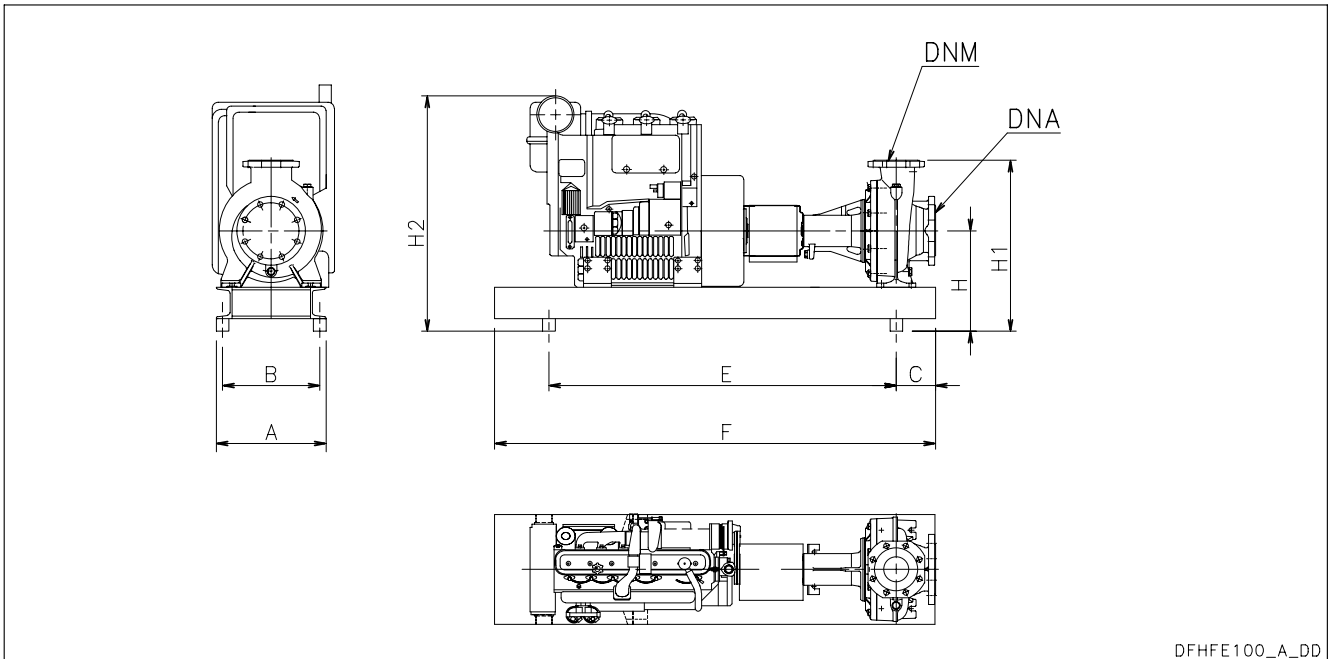

DFHFE100_A_DD

For the overall dimensions of the fuel tank and the starting batteries, see tables on pages 20-25.

DFHF 32-80 DIESEL ENGINE PUMP SERIES FIRE-FIGHTING EN 12845

D..	DNA	DNM	A	B	C	E	F	H	H1	H2
FHFE32-125/D119	R 2"	32	400	350	80	710	900	262	402	630
FHFE32-125/D136	R 2"	32	400	350	80	710	900	262	402	630
FHFE32-160/D150	R 2"	32	400	350	80	690	900	282	442	650
FHFE32-160/D164	R 2"	32	400	350	80	690	900	282	442	650
FHFE32-200/D188	R 2"	32	400	350	80	690	900	260	440	630
FHFE32-200/D204	R 2"	32	500	450	80	790	950	310	490	710
FHFE40-125/D112	65	40	400	350	80	690	900	262	402	630
FHFE40-125/D122	65	40	400	350	80	690	900	262	402	630
FHFE40-125/D143	65	40	400	350	80	690	900	262	402	630
FHFE40-160/D159	65	40	400	350	80	690	900	282	442	650
FHFE40-160/D171	65	40	400	350	80	690	900	282	442	650
FHFE40-200/D190	65	40	500	450	100	770	950	310	490	710
FHFE40-200/D209	65	40	500	450	100	770	950	310	490	720
FHFE40-250/D218	65	40	530	480	100	820	1000	280	505	690
FHFE40-250/D233	65	40	530	480	100	920	1200	330	555	800
FHFE40-250/D251	65	40	530	480	100	920	1200	330	555	800
FHFE50-125/D119	65	50	400	350	100	690	950	282	442	650
FHFE50-125/D130	65	50	400	350	100	690	950	282	442	650
FHFE50-125/D139	65	50	500	450	100	740	950	282	442	650
FHFE50-160/D158	65	50	500	450	100	770	950	310	490	710
FHFE50-160/D174	65	50	500	450	100	770	950	310	490	720
FHFE50-200/D197	65	50	530	480	100	820	1000	310	510	720
FHFE50-200/D209	65	50	530	480	100	870	1200	360	560	830
FHFE50-250/D224	65	50	530	480	100	920	1200	330	555	800
FHFE50-250/D237	65	50	530	480	100	970	1300	380	605	800
FHFE50-250/D250	65	50	530	480	100	970	1300	380	605	900
FHFE65-125/D121	80	65	500	450	100	725	950	310	490	710
FHFE65-125/D129	80	65	500	450	100	755	950	310	490	710
FHFE65-125/D140	80	65	500	450	100	755	1000	310	490	720
FHFE65-160/D161	80	65	530	480	100	820	1000	310	510	720
FHFE65-160/D168	80	65	530	480	100	920	1200	360	560	830
FHFE65-160/D178	80	65	530	480	100	920	1200	360	560	830
FHFE65-200/D187	80	65	530	480	100	920	1200	330	555	800
FHFE65-200/D198	80	65	530	480	100	970	1350	380	605	800
FHFE65-200/D210	80	65	530	480	100	970	1350	380	605	800
FHFE65-250/D220	80	65	530	480	100	955	1450	360	610	880
FHFE65-250/D241	80	65	640	590	100	1130	1550	360	610	1000
FHFE65-250/D258	80	65	640	590	100	1130	1550	360	610	1010
FHFE80-160/D163	100	80	530	480	125	920	1250	330	555	800
FHFE80-160/D173	100	80	530	480	125	970	1350	380	605	800
FHFE80-200/D189	100	80	530	480	125	970	1450	380	630	900
FHFE80-200/D207	100	80	640	590	125	1095	1550	360	610	1000
FHFE80-250/D225	100	80	640	590	125	1130	1550	360	640	1010
FHFE80-250/D238	100	80	640	590	125	1180	1550	365	645	1030
FHFE80-250/D256	100	80	660	610	125	1240	1750	390	670	1080

Dimensions in mm. Tolerance ± 10 mm.

d_fhfe-en_h_td

GEN..D/FHF

DFHF 100-125 DIESEL ENGINE PUMP SERIES FIRE-FIGHTING EN 12845

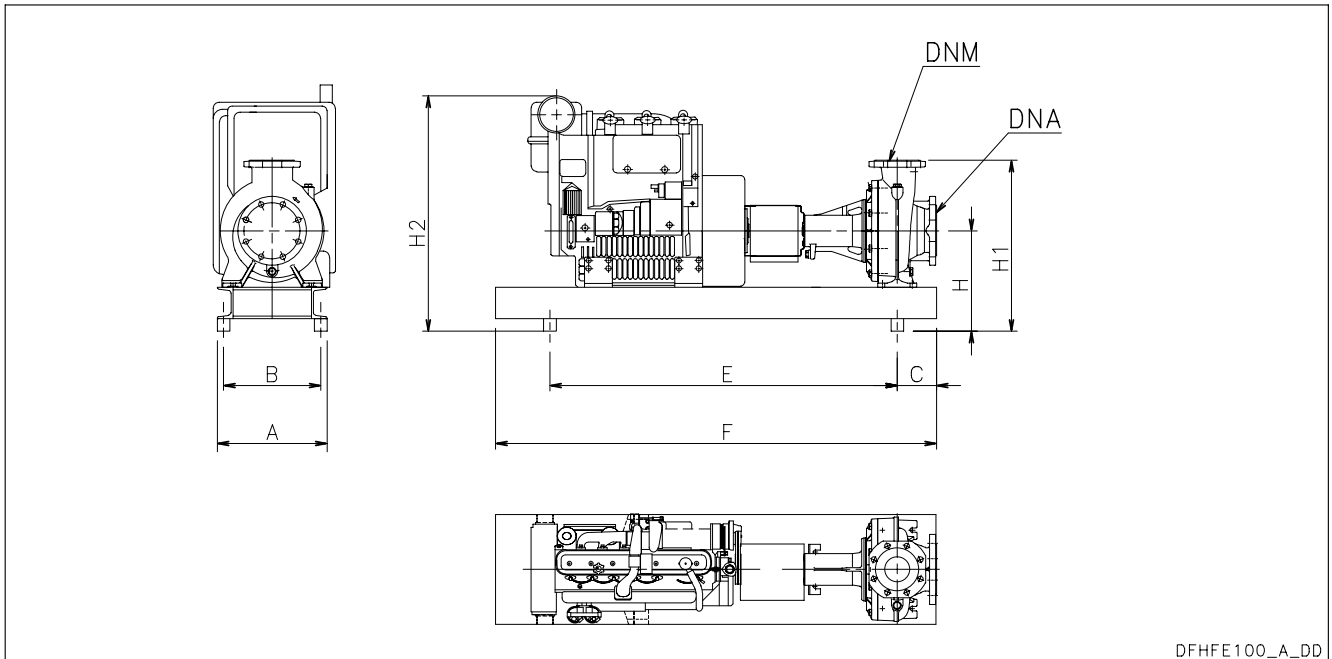

DFHFE100_A_DD

For the overall dimensions of the fuel tank and the starting batteries, see tables on pages 20-25.

GEN..D/FHF

D..	DNA	DNM	A	B	C	E	F	H	H1	H2
FHFE100-160/D150	125	100	530	480	125	1000	1350	348	628	870
FHFE100-160/D165	125	100	530	480	125	960	1450	398	678	870
FHFE100-160/D185	125	100	640	590	125	1150	1550	348	628	990
FHFE100-200/D168	125	100	530	480	125	1000	1450	373	653	800
FHFE100-200/D192	125	100	640	590	125	1150	1550	373	653	1010
FHFE100-200/D203	125	100	640	590	125	1200	1550	373	653	1000
FHFE100-200/D213	125	100	640	590	125	1140	1550	368	648	1010
FHFE100-250/D200	125	100	640	590	140	1200	1600	348	628	990
FHFE100-250/D221	125	100	640	590	140	1200	1600	348	628	1000
FHFE100-250/D235	125	100	640	590	140	1190	1750	393	673	1080
FHFE100-250/D254	125	100	700	650	140	1300	2050	373	653	1040
FHFE100-250/D267	125	100	700	650	140	1300	2050	373	653	1040
FHFE125-200/D180	150	125	640	590	140	1200	1650	373	688	1010
FHFE125-200/D206	150	125	640	590	140	1190	1650	343	658	1000
FHFE125-200/D216	150	125	640	590	140	1190	1800	393	708	1080
FHFE125-270/D224	150	125	700	650	140	1300	2100	423	778	1090
FHFE125-270/D237	150	125	700	650	140	1300	2100	423	778	1100
FHFE125-270/D253	150	125	800	750	140	1300	2050	478	833	1350
FHFE125-270/D266	150	125	800	750	140	1300	2050	478	833	1350

Dimensions in mm. Tolerance ± 10 mm.

d_fhfe100-en_e_td

**Fire-fighting
booster sets
EN 12845**

MARKET SECTORS

CIVIL, INDUSTRIAL

APPLICATIONS

- Fixed fire-fighting systems.
Automatic Sprinkler systems.

**GEN..00D/FHF
Series**

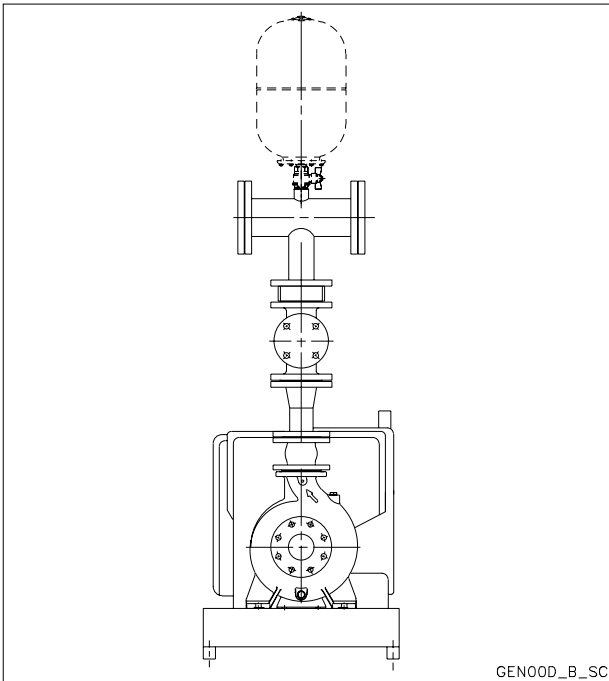

GEN..D/FHF

SPECIFICATIONS

- **Flow** up to 650 m³/h.
- **Head** up to 100 m.
- Panel supply power voltage:
1 x 230V ± 10%.
- Frequency: 50 Hz.
- Voltage for controls outside panel:
12 - 24 Vac.
- Protection grade:
- electric panel: IP54.
- Electric pumps maximum power
132 kW.
- Diesel engine with battery start.
- **Diesel engine service pump
in horizontal design:**
- FHF series.
- Maximum running pressure: 12 bar.

**GEN..00D/FHF 32-80 SERIES
FIRE-FIGHTING BOOSTER SETS EN 12845**

GEN..D/FHF

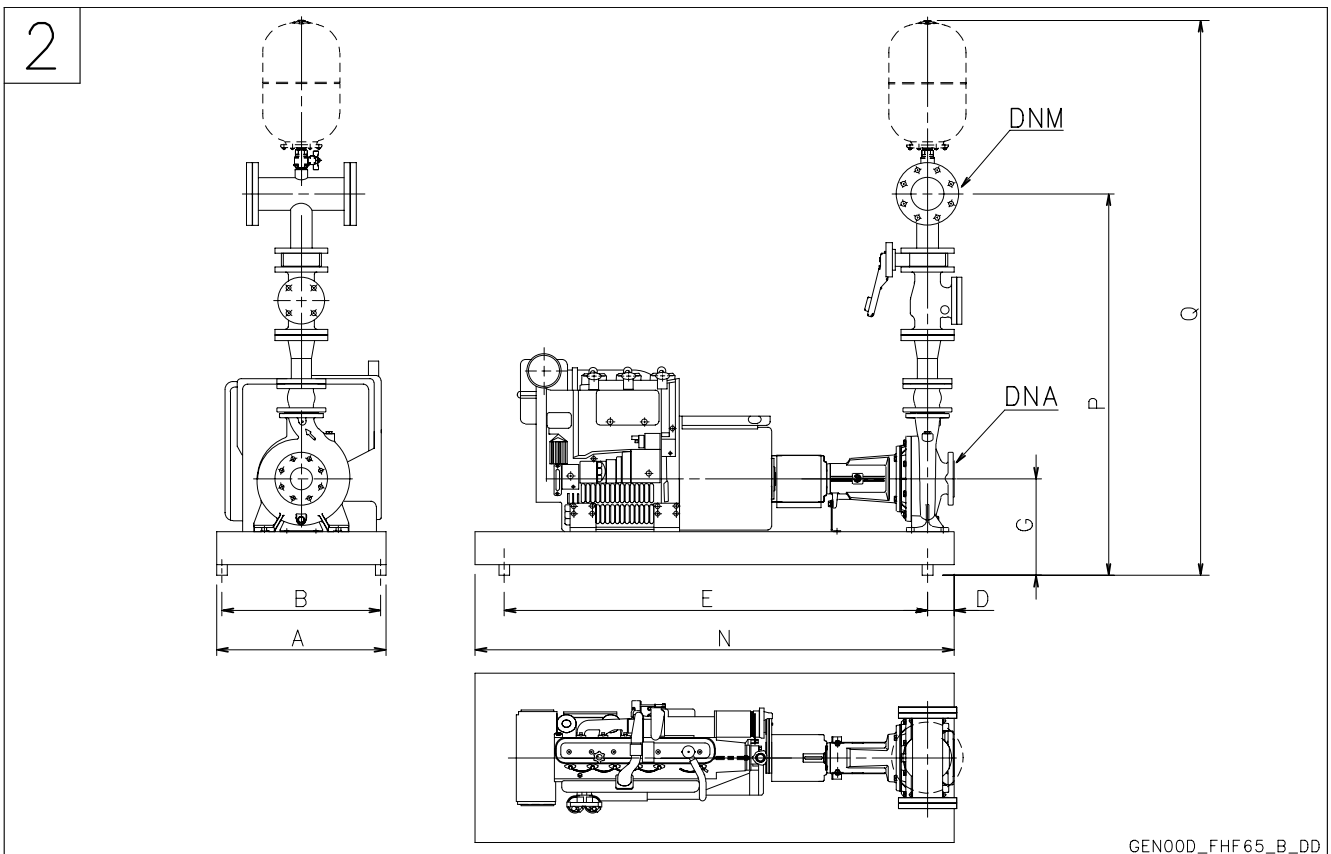
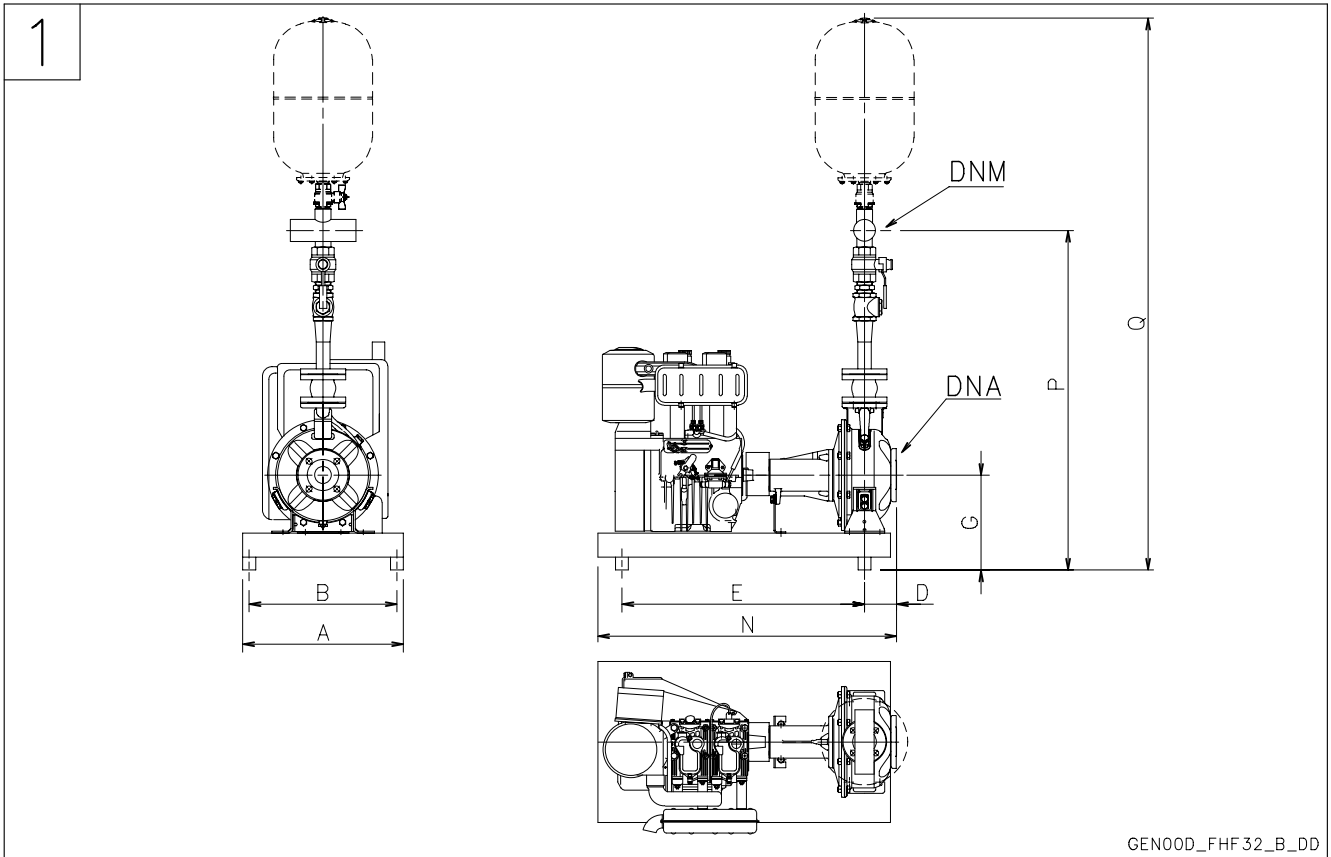

For the overall dimensions of the fuel tank and the starting batteries, see tables on pages 20-25.

**GEN..00D/FHF 32-80 SERIES
FIRE-FIGHTING BOOSTER SETS EN 12845**

GEN..00D	DRW N°	DNA	DNM	A	B	D	E	G	N	P	Q
FHF32-125/D119	1	R 2"	R 1"1/2	400	350	80	710	262	900	913	1487
FHF32-125/D136	1	R 2"	R 1"1/2	400	350	80	710	262	900	913	1487
FHF32-160/D150	1	R 2"	R 1"1/2	400	350	80	690	282	900	953	1527
FHF32-160/D164	1	R 2"	R 1"1/2	400	350	80	690	282	900	953	1527
FHF32-200/D188	1	R 2"	R 1"1/2	400	350	80	690	260	900	951	1525
FHF32-200/D204	1	R 2"	R 1"1/2	500	450	80	790	310	950	1001	1575
FHF40-125/D112	2	65	65	400	350	80	690	262	900	1109	1697
FHF40-125/D122	2	65	65	400	350	80	690	262	900	1109	1697
FHF40-125/D143	2	65	65	400	350	80	690	262	900	1109	1697
FHF40-160/D159	2	65	65	400	350	80	690	282	900	1149	1737
FHF40-160/D171	2	65	65	400	350	80	690	282	900	1149	1737
FHF40-200/D190	2	65	65	500	450	100	770	310	950	1197	1785
FHF40-200/D209	2	65	65	500	450	100	770	310	950	1197	1785
FHF40-250/D218	2	65	65	530	480	100	820	280	1000	1212	1800
FHF40-250/D233	2	65	65	530	480	100	920	330	1200	1262	1850
FHF40-250/D251	2	65	65	530	480	100	920	330	1200	1262	1850
FHF50-125/D119	2	65	65	400	350	100	690	282	950	1241	1829
FHF50-125/D130	2	65	65	400	350	100	690	282	950	1241	1829
FHF50-125/D139	2	65	65	500	450	100	740	282	950	1241	1829
FHF50-160/D158	2	65	65	500	450	100	770	310	950	1289	1877
FHF50-160/D174	2	65	65	500	450	100	770	310	950	1289	1877
FHF50-200/D197	2	65	65	530	480	100	820	310	1000	1309	1897
FHF50-200/D209	2	65	65	530	480	100	870	360	1200	1359	1947
FHF50-250/D224	2	65	65	530	480	100	920	330	1200	1354	1942
FHF50-250/D237	2	65	65	530	480	100	970	380	1300	1404	1992
FHF50-250/D250	2	65	65	530	480	100	970	380	1300	1404	1992
FHF65-125/D121	2	80	80	500	450	100	725	310	950	1356	1950
FHF65-125/D129	2	80	80	500	450	100	755	310	950	1356	1950
FHF65-125/D140	2	80	80	500	450	100	755	310	1000	1356	1950
FHF65-160/D161	2	80	80	530	480	100	820	310	1000	1376	1970
FHF65-160/D168	2	80	80	530	480	100	920	360	1200	1426	2020
FHF65-160/D178	2	80	80	530	480	100	920	360	1200	1426	2020
FHF65-200/D187	2	80	80	530	480	100	920	330	1200	1421	2015
FHF65-200/D198	2	80	80	530	480	100	970	380	1350	1471	2065
FHF65-200/D210	2	80	80	530	480	100	970	380	1350	1471	2065
FHF65-250/D220	2	80	80	530	480	100	955	360	1450	1476	2070
FHF65-250/D241	2	80	80	640	590	100	1130	360	1550	1476	2070
FHF65-250/D258	2	80	80	640	590	100	1130	360	1550	1476	2070
FHF80-160/D163	2	100	100	530	480	125	920	330	1250	1504	2111
FHF80-160/D173	2	100	100	530	480	125	970	380	1350	1554	2161
FHF80-200/D189	2	100	100	530	480	125	970	380	1450	1579	2186
FHF80-200/D207	2	100	100	640	590	125	1095	360	1550	1559	2166
FHF80-250/D225	2	100	100	640	590	125	1130	360	1550	1589	2196
FHF80-250/D238	2	100	100	640	590	125	1180	365	1550	1594	2201
FHF80-250/D256	2	100	100	660	610	125	1240	390	1750	1619	2226

Dimensions in mm. Tolerance ± 10 mm.

gen00d_fhf-en_h_td

GEN..D/FHF

GEN..00D/FHF 100-125 SERIES FIRE-FIGHTING BOOSTER SETS EN 12845

GEN..D/FHF

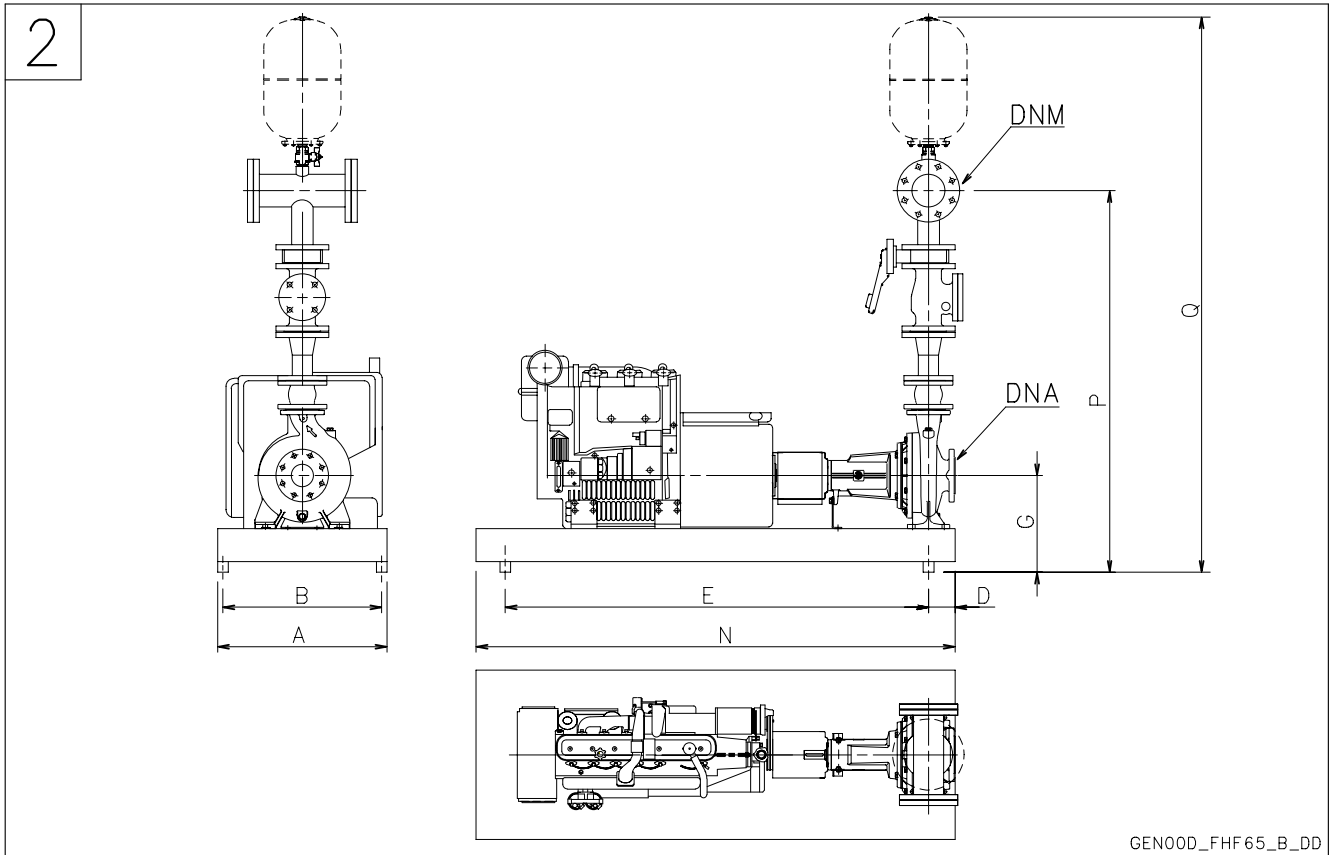

For the overall dimensions of the fuel tank and the starting batteries, see tables on pages 20-25.

GEN..00D	DRW N°	DNA	DNM	A	B	D	E	G	N	P	Q
FHF100-160/D150	2	125	125	530	480	125	1000	348	1350	1676	2296
FHF100-160/D165	2	125	125	530	480	125	960	398	1450	1726	2346
FHF100-160/D185	2	125	125	640	590	125	1150	348	1550	1676	2296
FHF100-200/D168	2	125	125	530	480	125	1000	373	1450	1701	2321
FHF100-200/D192	2	125	125	640	590	125	1150	373	1550	1701	2321
FHF100-200/D203	2	125	125	640	590	125	1200	373	1550	1701	2321
FHF100-200/D213	2	125	125	640	590	125	1140	368	1550	1696	2316
FHF100-250/D200	2	125	125	640	590	140	1200	348	1600	1676	2296
FHF100-250/D221	2	125	125	640	590	140	1200	348	1600	1676	2296
FHF100-250/D235	2	125	125	640	590	140	1190	393	1750	1721	2341
FHF100-250/D254	2	125	125	700	650	140	1300	373	2050	1701	2321
FHF100-250/D267	2	125	125	700	650	140	1300	373	2050	1701	2321
FHF125-200/D180	2	150	150	640	590	140	1200	373	1650	1868	2502
FHF125-200/D206	2	150	150	640	590	140	1190	343	1650	1838	2472
FHF125-200/D216	2	150	150	640	590	140	1190	393	1800	1888	2522
FHF125-270/D224	2	150	150	700	650	140	1300	423	2100	1958	2592
FHF125-270/D237	2	150	150	700	650	140	1300	423	2100	1958	2592
FHF125-270/D253	2	150	150	800	750	140	1300	478	2050	2013	2647
FHF125-270/D266	2	150	150	800	750	140	1300	478	2050	2013	2647

Dimensions in mm. Tolerance ± 10 mm.

gen00d_fhf100-en_f_td

**Fire-fighting
booster sets
EN 12845**

MARKET SECTORS

CIVIL, INDUSTRIAL

APPLICATIONS

- Fixed fire-fighting systems.
Automatic Sprinkler systems.

**GEN..01D/FHF
Series**

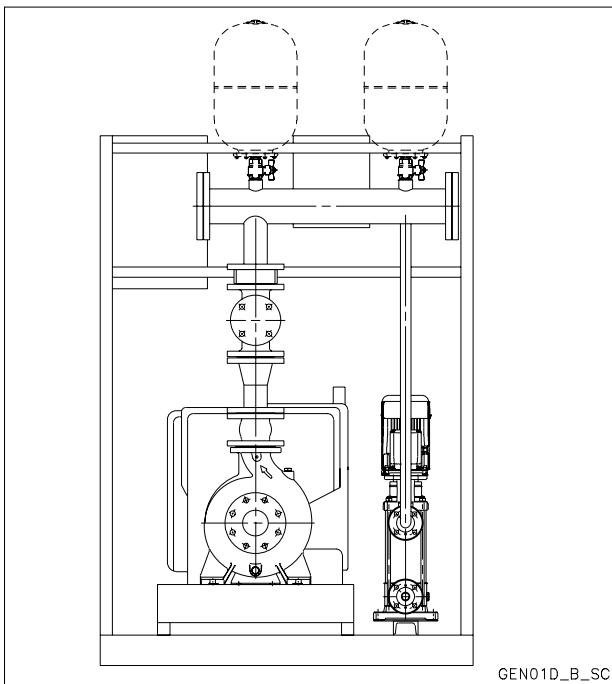

GEN..D/FHF

SPECIFICATIONS

- **Flow** up to 650 m³/h.
- **Head** up to 100 m.
- Panel supply power voltage:
 - Electric pump: 1 x 230V ± 10%.
 - Diesel engine pump: 1 x 230V ± 10%.
- Frequency: 50 Hz.
- Voltage for controls outside panel: 12 - 24 Vac.
- Protection grade:
 - electric panel: IP54.
- Electric pumps maximum power 132 kW.
- Electric motor start :
 - Direct start for powers up to 22 kW included for electric pump.
- Diesel engine with battery start.
- **Service pump in horizontal design:**
 - FHF series.
- **Electric jockey pump with vertical axis:**
 - SV Series (motor protection grade IP55).
- Maximum running pressure: 12 bar.

**GEN..01D/FHF 32-80 SERIES
FIRE-FIGHTING BOOSTER SETS EN 12845**

GEN..D/FHF

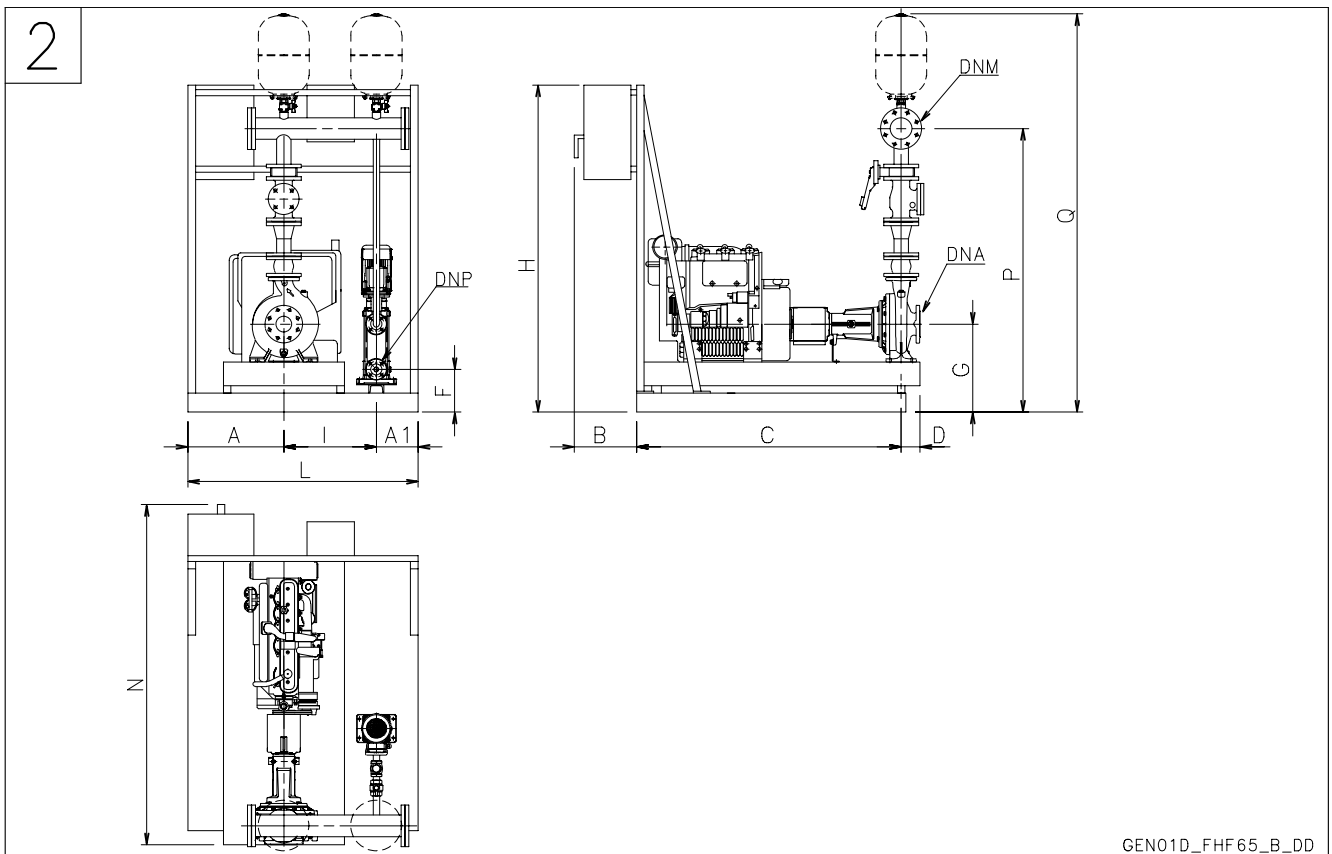
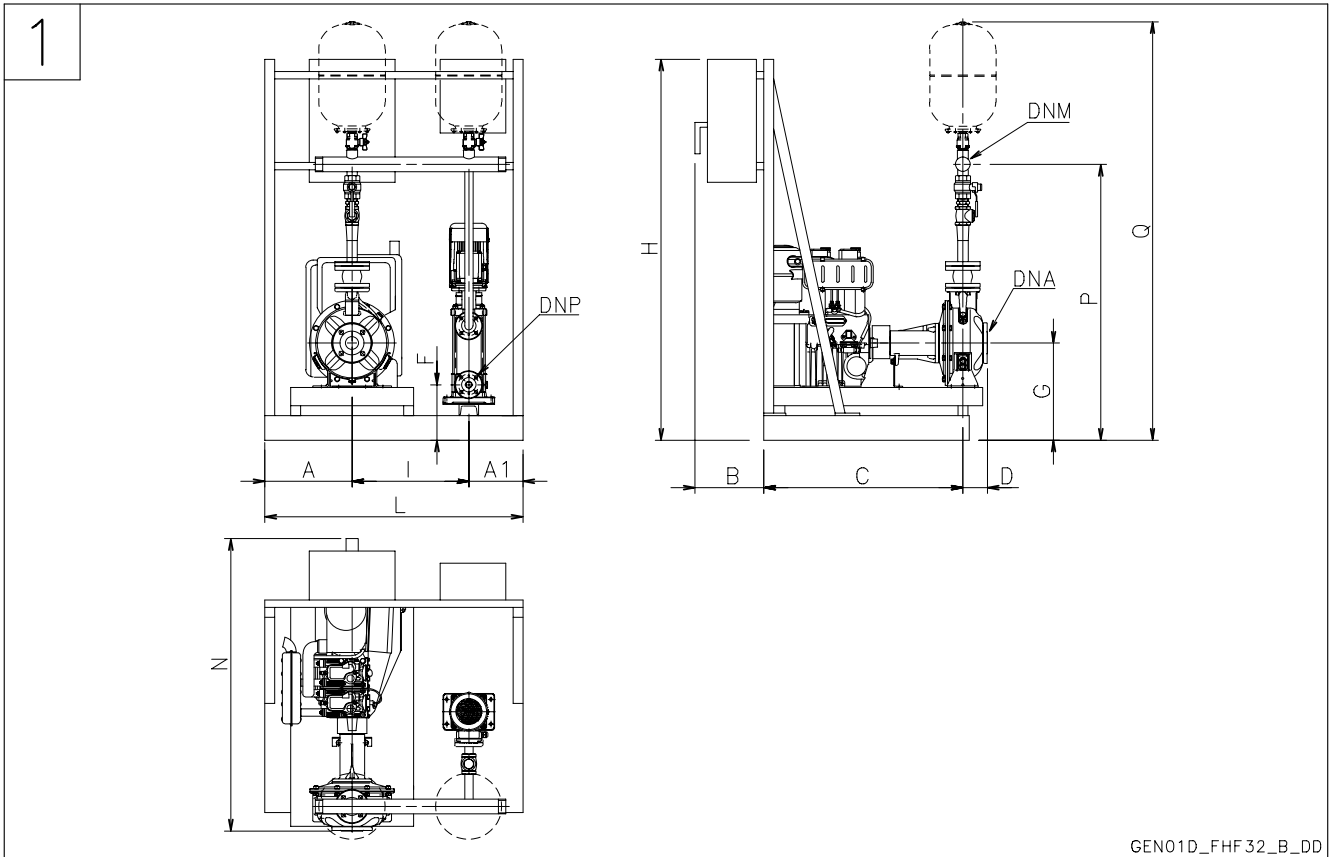

For the overall dimensions of the fuel tank and the starting batteries, see tables on pages 20-25.

GEN..01D/FHF 32-80 SERIES FIRE-FIGHTING BOOSTER SETS EN 12845

GEN..01D	DRW N°	DNA	DNP	DNM	A	A1	B	C	D	F	G	H	I	L	N	P	Q
FHF32-125/D119	1	R 2"	Rp 1"	R 1"1/2	330	220	280	905	80	225	362	1400	400	950	1265	1013	1587
FHF32-125/D136	1	R 2"	Rp 1"	R 1"1/2	330	220	280	905	80	225	362	1400	400	950	1265	1013	1587
FHF32-160/D150	1	R 2"	Rp 1"	R 1"1/2	330	220	280	885	80	225	382	1400	400	950	1245	1053	1627
FHF32-160/D164	1	R 2"	Rp 1"	R 1"1/2	330	220	280	885	80	225	382	1400	400	950	1245	1053	1627
FHF32-200/D188	1	R 2"	Rp 1"	R 1"1/2	330	220	280	885	80	225	360	1400	400	950	1245	1051	1625
FHF32-200/D204	1	R 2"	Rp 1"	R 1"1/2	400	225	280	1005	80	225	410	1400	475	1100	1365	1101	1675
FHF40-125/D112	2	65	Rp 1"	65	330	220	280	885	80	225	362	1400	400	950	1245	1206	1794
FHF40-125/D122	2	65	Rp 1"	65	330	220	280	885	80	225	362	1400	400	950	1245	1206	1794
FHF40-125/D143	2	65	Rp 1"	65	330	220	280	885	80	225	362	1400	400	950	1245	1206	1794
FHF40-160/D159	2	65	Rp 1"	65	330	220	280	885	80	225	382	1400	400	950	1245	1246	1834
FHF40-160/D171	2	65	Rp 1"	65	330	220	280	885	80	225	382	1400	400	950	1245	1246	1834
FHF40-200/D190	2	65	Rp 1"	65	400	225	280	985	100	225	410	1400	475	1100	1365	1294	1882
FHF40-200/D209	2	65	Rp 1"	65	400	225	280	985	100	225	410	1400	475	1100	1365	1294	1882
FHF40-250/D218	2	65	Rp 1"	65	390	235	280	975	100	225	380	1400	475	1100	1355	1309	1897
FHF40-250/D233	2	65	Rp 1"	65	390	235	280	1170	100	225	430	1400	475	1100	1550	1359	1947
FHF40-250/D251	2	65	Rp 1"	65	390	235	280	1170	100	225	430	1400	475	1100	1550	1359	1947
FHF50-125/D119	2	65	Rp 1"	65	330	220	280	885	100	225	382	1400	400	950	1265	1338	1926
FHF50-125/D130	2	65	Rp 1"	65	330	220	280	885	100	225	382	1400	400	950	1265	1338	1926
FHF50-125/D139	2	65	Rp 1"	65	400	225	280	955	100	225	382	1400	475	1100	1335	1338	1926
FHF50-160/D158	2	65	Rp 1"	65	400	225	280	985	100	225	410	1400	475	1100	1365	1386	1974
FHF50-160/D174	2	65	Rp 1"	65	400	225	280	985	100	225	410	1400	475	1100	1365	1386	1974
FHF50-200/D197	2	65	Rp 1"	65	390	235	280	975	100	225	410	1400	475	1100	1355	1406	1994
FHF50-200/D209	2	65	Rp 1"	65	390	235	280	1120	100	225	460	1400	475	1100	1500	1456	2044
FHF50-250/D224	2	65	Rp 1"	65	390	235	280	1170	100	225	430	1400	475	1100	1550	1451	2039
FHF50-250/D237	2	65	Rp 1"	65	390	235	280	1220	100	225	480	1550	475	1100	1600	1501	2089
FHF50-250/D250	2	65	Rp 1"	65	390	235	280	1220	100	225	480	1550	475	1100	1600	1501	2089
FHF65-125/D121	2	80	Rp 1"	80	400	225	280	940	100	225	410	1400	475	1100	1320	1453	2047
FHF65-125/D129	2	80	Rp 1"	80	400	225	280	970	100	225	410	1400	475	1100	1350	1453	2047
FHF65-125/D140	2	80	Rp 1"	80	400	225	280	970	100	225	410	1400	475	1100	1350	1453	2047
FHF65-160/D161	2	80	Rp 1"	80	390	235	280	975	100	225	410	1400	475	1100	1355	1473	2067
FHF65-160/D168	2	80	Rp 1"	80	390	235	280	1170	100	225	460	1400	475	1100	1550	1523	2117
FHF65-160/D178	2	80	Rp 1"	80	390	235	280	1170	100	225	460	1400	475	1100	1550	1523	2117
FHF65-200/D187	2	80	Rp 1"	80	390	235	280	1170	100	225	430	1400	475	1100	1550	1518	2112
FHF65-200/D198	2	80	Rp 1"	80	390	235	280	1220	100	225	480	1550	475	1100	1600	1568	2162
FHF65-200/D210	2	80	Rp 1"	80	390	235	280	1220	100	225	480	1550	475	1100	1600	1568	2162
FHF65-250/D220	2	80	Rp 1"	80	390	235	280	1305	100	225	460	1550	475	1100	1685	1573	2167
FHF65-250/D241	2	80	Rp 1"	80	460	380	180	1270	100	245	480	1750	530	1370	1550	1593	2187
FHF65-250/D258	2	80	Rp 1"	80	460	380	180	1270	100	245	480	1750	530	1370	1550	1593	2187
FHF80-160/D163	2	100	Rp 1"	100	390	235	280	1170	125	225	430	1400	475	1100	1575	1601	2208
FHF80-160/D173	2	100	Rp 1"	100	390	235	280	1220	125	225	480	1550	475	1100	1625	1651	2258
FHF80-200/D189	2	100	Rp 1"	100	390	235	280	1370	125	225	480	1550	475	1100	1775	1676	2283
FHF80-200/D207	2	100	Rp 1"	100	500	270	280	1440	125	245	480	1750	530	1300	1845	1676	2283
FHF80-250/D225	2	100	Rp 1"	100	460	380	155	1270	125	245	480	1750	530	1370	1550	1706	2313
FHF80-250/D238	2	100	Rp 1"	100	505	265	280	1550	125	245	485	1940	530	1300	1955	1711	2318
FHF80-250/D256	2	100	Rp 1"	100	505	265	245	1380	125	265	530	1960	530	1300	1750	1756	2363

Dimensions in mm. Tolerance \pm 10 mm.

gen01d_fhf-en_g_td

GEN..D/FHF

**GEN..01D/FHF 100-125 SERIES
FIRE-FIGHTING BOOSTER SETS EN 12845**

GEN..D/FHF

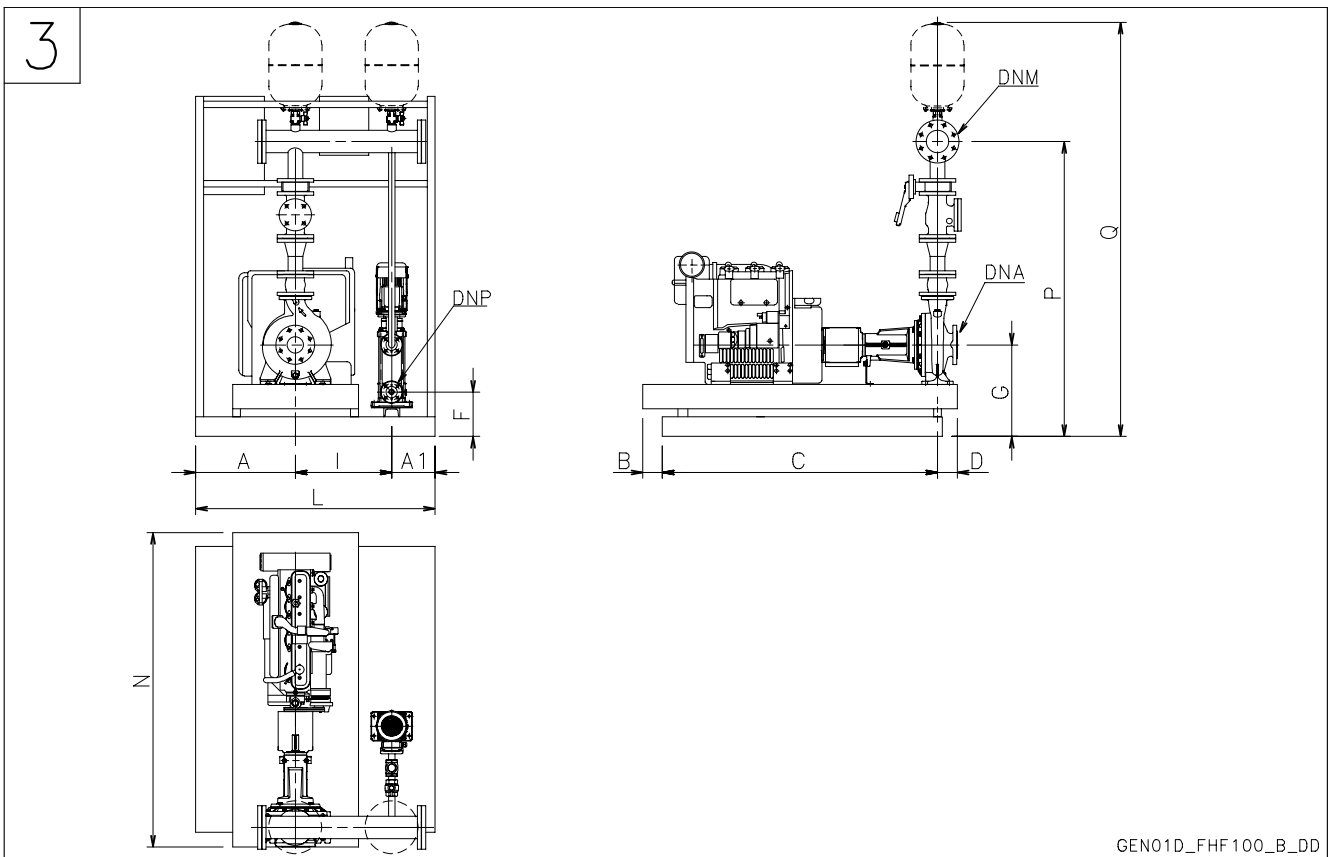
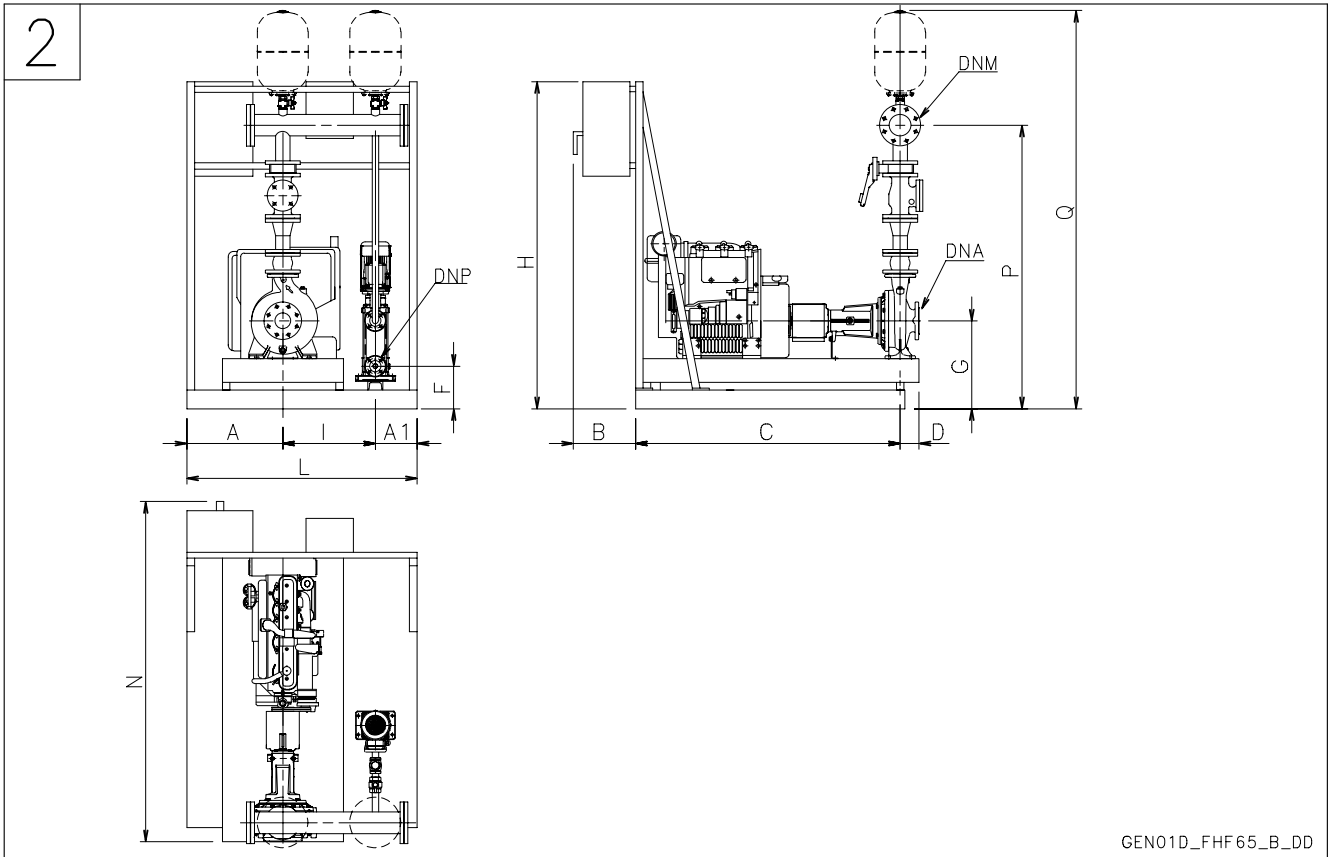

For the overall dimensions of the fuel tank and the starting batteries, see tables on pages 20-25.

GEN..01D/FHF 100-125 SERIES FIRE-FIGHTING BOOSTER SETS EN 12845

GEN..01D	DRW N°	DNA	DNP	DNM	A	A1	B	C	D	F	G	H	I	L	N	P	Q
FHF100-160/D150	2	125	Rp 1"	125	390	235	280	1300	125	225	448	1550	475	1100	1705	1773	2393
FHF100-160/D165	2	125	Rp 1"	125	390	235	280	1360	125	225	498	1550	475	1100	1765	1823	2443
FHF100-160/D185	2	125	Rp 1"	125	460	380	135	1290	125	245	468	1750	530	1370	1550	1793	2413
FHF100-200/D168	2	125	Rp 1"	125	390	235	280	1300	125	225	473	1550	475	1100	1705	1798	2418
FHF100-200/D192	2	125	Rp 1"	125	460	380	135	1290	125	245	493	1750	530	1370	1550	1818	2438
FHF100-200/D203	2	125	Rp 1"	125	500	270	280	1545	125	245	493	1750	530	1300	1950	1818	2438
FHF100-200/D213	2	125	Rp 1"	125	500	270	280	1485	125	245	488	1750	530	1300	1890	1813	2433
FHF100-250/D200	2	125	Rp 1"	125	500	270	280	1545	140	245	468	1750	530	1300	1965	1793	2413
FHF100-250/D221	2	125	Rp 1"	125	500	270	280	1545	140	245	468	1750	530	1300	1965	1793	2413
FHF100-250/D235	2	125	Rp 1"	125	505	265	280	1660	140	245	513	1750	530	1300	2080	1838	2458
FHF100-250/D254	3	125	Rp 1"	125	550	265	570	1340	140	215	513	\	570	1385	2050	1838	2458
FHF100-250/D267	3	125	Rp 1"	125	550	265	570	1340	140	215	513	\	570	1385	2050	1838	2458
FHF125-200/D180	2	150	Rp 1"	150	500	270	280	1545	140	245	493	1750	530	1300	1965	1985	2619
FHF125-200/D206	2	150	Rp 1"	150	505	265	280	1560	140	245	463	1750	530	1300	1980	1955	2589
FHF125-200/D216	2	150	Rp 1"	150	505	265	280	1710	140	245	513	1940	530	1300	2130	2005	2639
FHF125-270/D224	3	150	Rp 1"	150	550	265	620	1340	140	220	563	\	570	1385	2100	2095	2729
FHF125-270/D237	3	150	Rp 1"	150	550	265	620	1340	140	220	563	\	570	1385	2100	2095	2729
FHF125-270/D253	3	150	Rp 1"	150	600	265	570	1340	140	220	618	\	620	1485	2050	2150	2784
FHF125-270/D266	3	150	Rp 1"	150	600	265	570	1340	140	220	618	\	620	1485	2050	2150	2784

Dimensions in mm. Tolerance \pm 10 mm.

gen01d_fhf100-en_f_td

**Fire-fighting
booster sets
EN 12845**

MARKET SECTORS

CIVIL, INDUSTRIAL

APPLICATIONS

- Fixed fire-fighting systems.
Automatic Sprinkler systems.

**GEN..10D/FHF
Series**

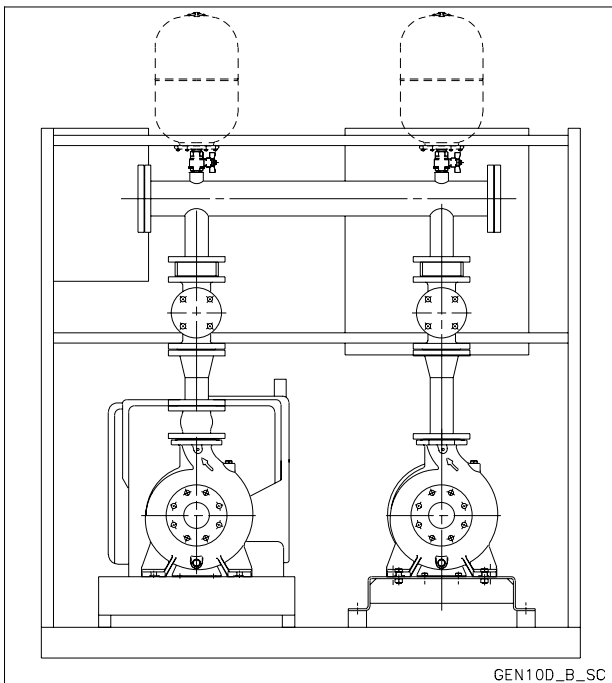

GEN..D/FHF

SPECIFICATIONS

- **Flow** up to 1300 m³/h.
- **Head** up to 100 m.
- Panel supply power voltage:
 - Electric pump: 3 x 400V ± 10%.
 - Diesel engine pump: 1 x 230V ± 10%.
- Frequency: 50 Hz.
- Voltage for controls outside panel: 12 - 24 Vac.
- Protection grade:
 - electric panel: IP54.
- Electric pumps maximum power 132 kW.
- Electric motor start :
 - Direct start for powers up to 22 kW included for pump (GEND...).
 - Star/delta start for higher powers (GENY... set).
- Diesel engine with battery start.
- **Service pump in horizontal design:**
 - FHF series (IP55 electric motor protection).
- Maximum running pressure: 12 bar.

**GEN..10D/FHF 32-80 SERIES
FIRE-FIGHTING BOOSTER SETS EN 12845**

GEN..D/FHF

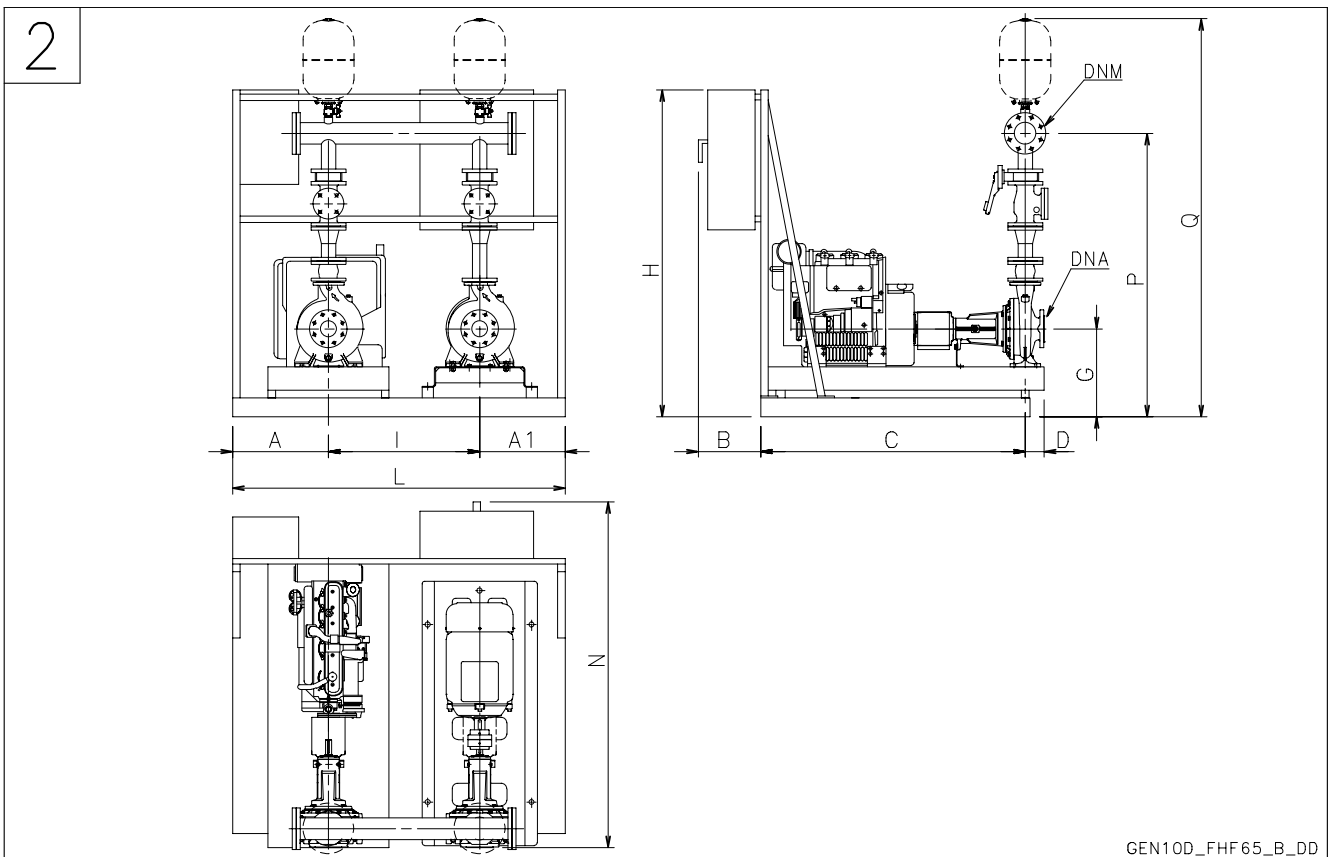
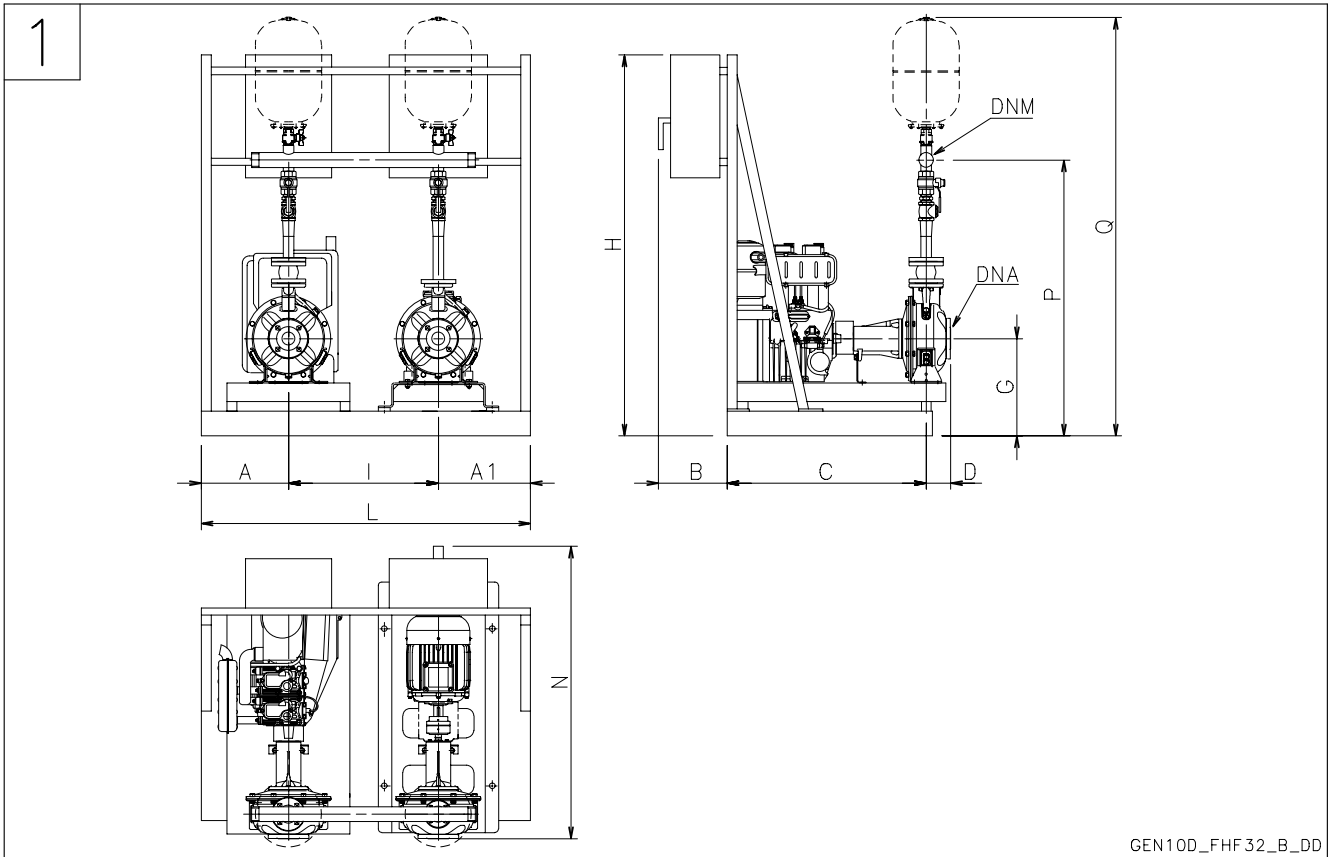

For the overall dimensions of the fuel tank and the starting batteries, see tables on pages 20-25.

GEN..10D/FHF 32-80 SERIES FIRE-FIGHTING BOOSTER SETS EN 12845

GEN..10D	DRW N°	DNA	DNM	A	A1	B	C	D	G	H	I	L	N	P	Q
FHF32-125/07/D119	1	R 2"	R 2"	320	310	240	870	80	362	1400	470	1100	1190	1019	1599
FHF32-125/11/D136	1	R 2"	R 2"	320	310	240	870	80	362	1400	470	1100	1190	1019	1599
FHF32-160/15/D150	1	R 2"	R 2"	320	310	240	850	80	382	1400	470	1100	1170	1059	1639
FHF32-160/22/D164	1	R 2"	R 2"	320	310	240	850	80	382	1400	470	1100	1170	1059	1639
FHF32-200/30/D188	1	R 2"	R 2"	320	310	240	850	80	360	1400	470	1100	1170	1057	1637
FHF32-200/40/D204	1	R 2"	R 2"	380	350	240	960	80	410	1400	570	1300	1280	1107	1687
FHF40-125/11/D112	2	65	65	320	310	240	850	80	362	1400	470	1100	1170	1206	1794
FHF40-125/15/D122	2	65	65	320	310	240	850	80	362	1400	470	1100	1170	1206	1794
FHF40-125/22/D143	2	65	65	320	310	240	850	80	362	1400	470	1100	1170	1206	1794
FHF40-160/30/D159	2	65	65	320	310	240	850	80	382	1400	470	1100	1170	1246	1834
FHF40-160/40/D171	2	65	65	320	310	240	850	80	382	1400	470	1100	1170	1246	1834
FHF40-200/55/D190	2	65	65	380	350	240	940	100	410	1400	570	1300	1280	1294	1882
FHF40-200/75/D209	2	65	65	380	350	240	940	100	410	1400	570	1300	1280	1294	1882
FHF40-250/110A/D218	2	65	65	420	370	180	1145	100	380	1400	610	1400	1425	1309	1897
FHF40-250/110/D233	2	65	65	420	370	280	1225	100	430	1400	610	1400	1605	1359	1947
FHF40-250/150/D251	2	65	65	420	370	280	1225	100	430	1400	610	1400	1605	1359	1947
FHF50-125/22/D119	2	65	80	320	310	240	850	100	382	1400	470	1100	1190	1345	1939
FHF50-125/30/D130	2	65	80	320	310	240	850	100	382	1400	470	1100	1190	1345	1939
FHF50-125/40/D139	2	65	80	380	350	240	910	100	382	1400	570	1300	1250	1345	1939
FHF50-160/55/D158	2	65	80	380	350	240	940	100	410	1400	570	1300	1280	1393	1987
FHF50-160/75/D174	2	65	80	380	350	240	940	100	410	1400	570	1300	1280	1393	1987
FHF50-200/110A/D197	2	65	80	420	370	110	1080	100	410	1400	610	1400	1290	1413	2007
FHF50-200/110/D209	2	65	80	420	370	110	1080	100	460	1400	610	1400	1290	1463	2057
FHF50-250/150/D224	2	65	80	420	370	280	1225	100	430	1400	610	1400	1605	1458	2052
FHF50-250/185/D237	2	65	80	420	370	280	1275	100	480	1550	610	1400	1655	1508	2102
FHF50-250/220/D250	2	65	80	420	370	280	1275	100	480	1550	610	1400	1655	1508	2102
FHF65-125/40/D121	2	80	100	380	350	240	895	100	410	1400	570	1300	1235	1465	2072
FHF65-125/55/D129	2	80	100	380	350	240	925	100	410	1400	570	1300	1265	1465	2072
FHF65-125/75/D140	2	80	100	380	350	240	925	100	410	1400	570	1300	1265	1465	2072
FHF65-160/110A/D161	2	80	100	420	370	180	1145	100	410	1400	610	1400	1425	1485	2092
FHF65-160/110/D168	2	80	100	420	370	280	1225	100	460	1400	610	1400	1605	1535	2142
FHF65-160/150/D178	2	80	100	420	370	280	1225	100	460	1400	610	1400	1605	1535	2142
FHF65-200/150/D187	2	80	100	420	370	280	1225	100	430	1400	610	1400	1605	1530	2137
FHF65-200/185/D198	2	80	100	420	370	280	1275	100	480	1550	610	1400	1655	1580	2187
FHF65-200/220/D210	2	80	100	420	370	280	1275	100	480	1550	610	1400	1655	1580	2187
FHF65-250/220/D220	2	80	100	420	370	280	1260	100	460	1550	610	1400	1640	1585	2192
FHF65-250/300/D241	2	80	100	480	450	280	1450	100	480	1750	730	1660	1830	1605	2212
FHF65-250/370/D258	2	80	100	480	450	280	1450	100	480	1750	730	1660	1830	1605	2212
FHF80-160/150/D163	2	100	125	420	370	280	1225	125	430	1400	610	1400	1630	1614	2234
FHF80-160/185/D173	2	100	125	420	370	280	1275	125	480	1550	610	1400	1680	1664	2284
FHF80-200/220/D189	2	100	125	420	370	280	1275	125	480	1550	610	1400	1680	1689	2309
FHF80-200/300/D207	2	100	125	480	450	280	1415	125	480	1750	730	1660	1820	1689	2309
FHF80-250/370/D225	2	100	125	480	450	280	1450	125	480	1750	730	1660	1855	1719	2339
FHF80-250/450/D238	2	100	125	480	450	320	1450	125	485	1940	730	1660	1895	1724	2344
FHF80-250/550/D256	2	100	125	480	450	320	1505	125	530	1960	730	1660	1950	1769	2389

Dimensions in mm. Tolerance ± 10 mm.

gen10d_fhf-en_g_td

**Fire-fighting
booster sets
EN 12845**

MARKET SECTORS

CIVIL, INDUSTRIAL

APPLICATIONS

- Fixed fire-fighting systems.
Automatic Sprinkler systems.

**GEN..11D/FHF
Series**

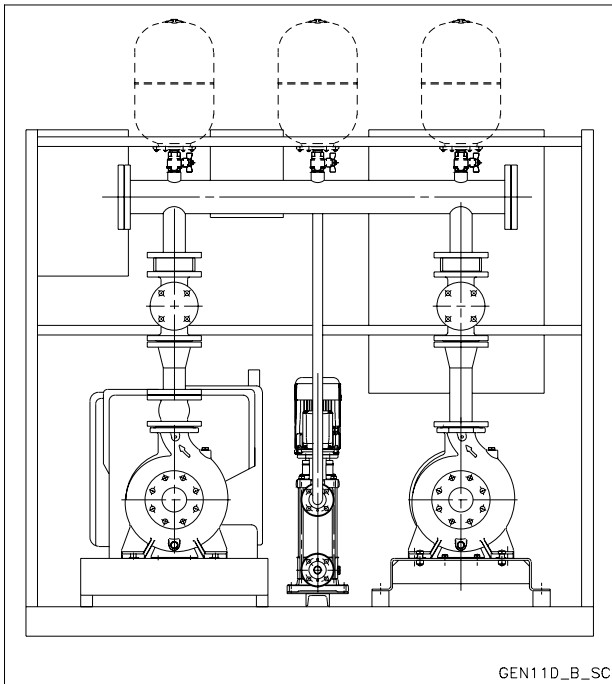

GEN..D/FHF

SPECIFICATIONS

- **Flow** up to 1300 m³/h.
- **Head** up to 100 m.
- Panel supply power voltage:
 - Electric pump: 3 x 400V ± 10%.
 - Diesel engine pump: 1 x 230V ± 10%.
- Frequency: 50 Hz.
- Voltage for controls outside panel: 12 - 24 Vac.
- Protection grade:
 - electric panel: IP54.
- Electric pumps maximum power 132 kW.
- Electric motor start :
 - Direct start for powers up to 22 kW included for pump (GEND...).
 - Star/delta start for higher powers (GENY... set).
- Diesel engine with battery start.
- **Service pump in horizontal design:**
 - FHF series (IP55 electric motor protection).
- **Electric jockey pump with vertical axis:**
 - SV Series (motor protection grade IP55).
- Maximum running pressure: 12 bar.

**GEN..11D/FHF 32-80 SERIES
FIRE-FIGHTING BOOSTER SETS EN 12845**

GEN..D/FHF

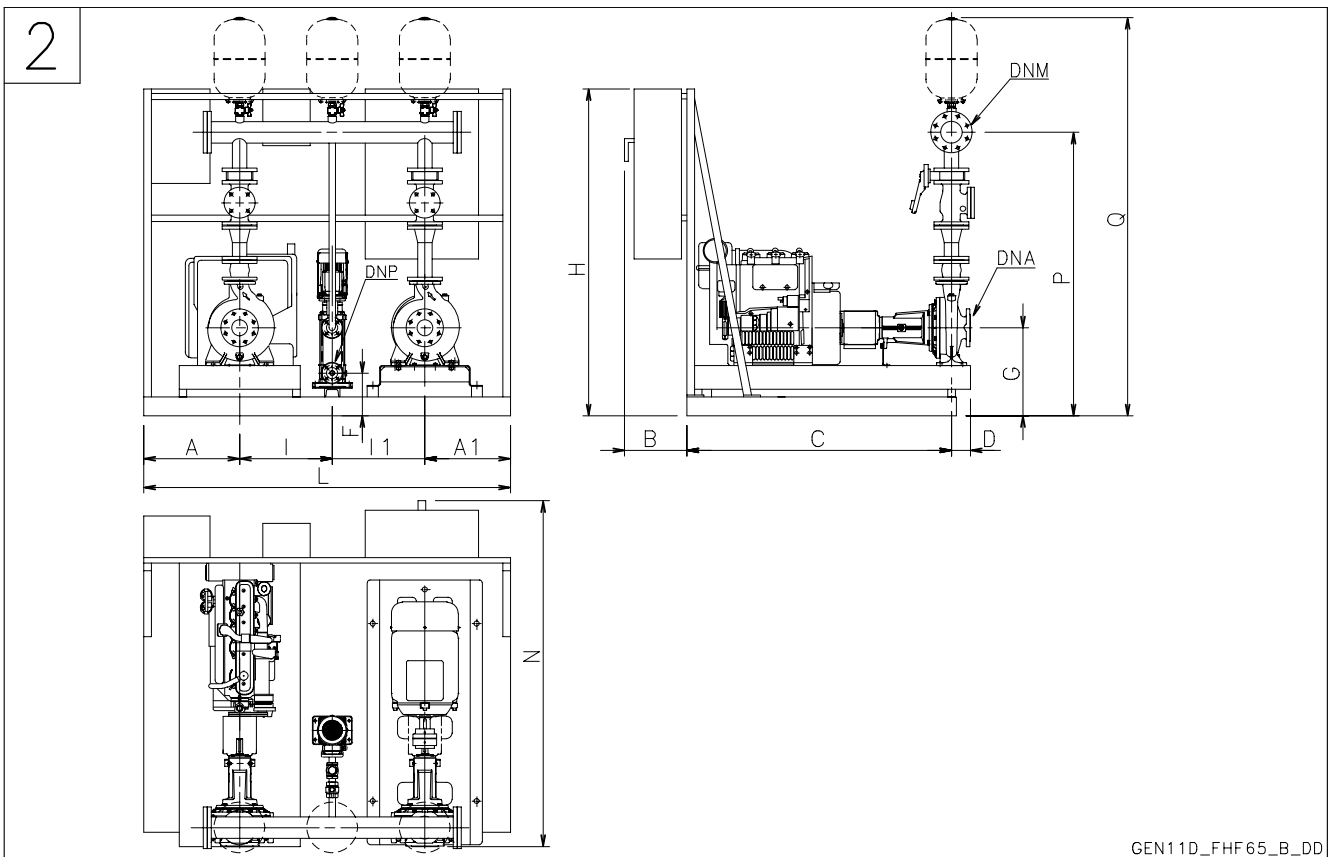
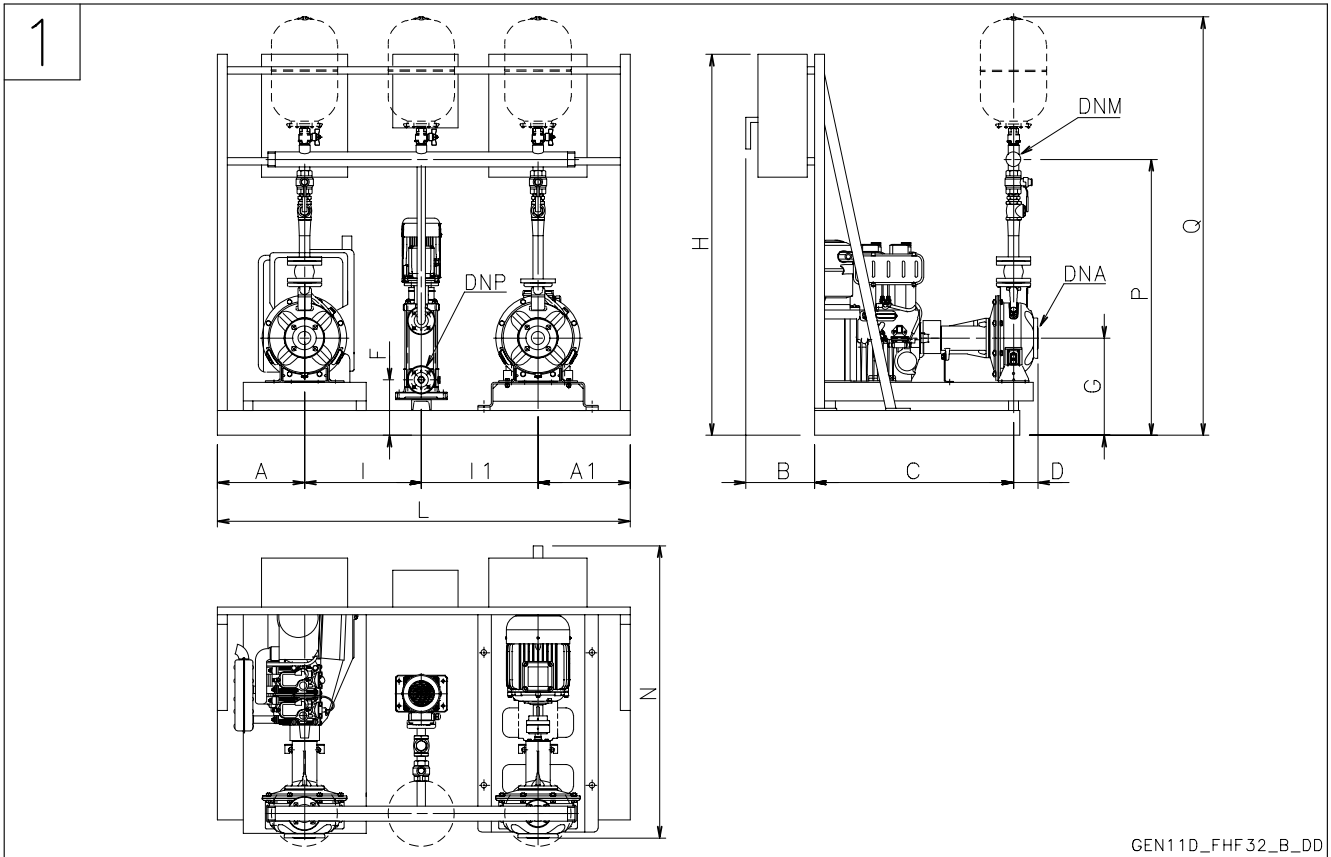

For the overall dimensions of the fuel tank and the starting batteries, see tables on pages 20-25.

GEN..11D/FHF 32-80 SERIES FIRE-FIGHTING BOOSTER SETS EN 12845

GEN..11D	DRW N°	DNA	DNP	DNM	A	A1	B	C	D	F	G	H	I	I1	L	N	P	Q
FHF32-125/07/D119	1	R 2"	Rp 1"	R 2"	305	295	240	905	80	225	362	1400	400	400	1400	1225	1019	1599
FHF32-125/11/D136	1	R 2"	Rp 1"	R 2"	305	295	240	905	80	225	362	1400	400	400	1400	1225	1019	1599
FHF32-160/15/D150	1	R 2"	Rp 1"	R 2"	305	295	240	850	80	225	382	1400	400	400	1400	1170	1059	1639
FHF32-160/22/D164	1	R 2"	Rp 1"	R 2"	305	295	240	850	80	225	382	1400	400	400	1400	1170	1059	1639
FHF32-200/30/D188	1	R 2"	Rp 1"	R 2"	305	295	240	850	80	225	360	1400	400	400	1400	1170	1057	1637
FHF32-200/40/D204	1	R 2"	Rp 1"	R 2"	400	375	240	1005	80	225	410	1400	475	430	1680	1325	1107	1687
FHF40-125/11/D112	2	65	Rp 1"	65	305	295	240	850	80	225	362	1400	400	400	1400	1170	1206	1794
FHF40-125/15/D122	2	65	Rp 1"	65	305	295	240	850	80	225	362	1400	400	400	1400	1170	1206	1794
FHF40-125/22/D143	2	65	Rp 1"	65	305	295	240	850	80	225	362	1400	400	400	1400	1170	1206	1794
FHF40-160/30/D159	2	65	Rp 1"	65	305	295	240	850	80	225	382	1400	400	400	1400	1170	1246	1834
FHF40-160/40/D171	2	65	Rp 1"	65	305	295	240	850	80	225	382	1400	400	400	1400	1170	1246	1834
FHF40-200/55/D190	2	65	Rp 1"	65	400	375	240	940	100	225	410	1400	475	430	1680	1280	1294	1882
FHF40-200/75/D209	2	65	Rp 1"	65	400	375	240	940	100	225	410	1400	475	430	1680	1280	1294	1882
FHF40-250/110A/D218	2	65	Rp 1"	65	365	355	180	995	100	225	380	1400	475	475	1670	1275	1309	1897
FHF40-250/110/D233	2	65	Rp 1"	65	375	385	280	995	100	225	430	1400	475	475	1710	1375	1359	1947
FHF40-250/150/D251	2	65	Rp 1"	65	375	385	280	995	100	225	430	1400	475	475	1710	1375	1359	1947
FHF50-125/22/D119	2	65	Rp 1"	80	305	295	240	850	100	225	382	1400	400	400	1400	1190	1345	1939
FHF50-125/30/D130	2	65	Rp 1"	80	305	295	240	850	100	225	382	1400	400	400	1400	1190	1345	1939
FHF50-125/40/D139	2	65	Rp 1"	80	400	375	240	1005	100	225	382	1400	475	430	1680	1345	1345	1939
FHF50-160/55/D158	2	65	Rp 1"	80	400	375	240	940	100	225	410	1400	475	430	1680	1280	1393	1987
FHF50-160/75/D174	2	65	Rp 1"	80	400	375	240	940	100	225	410	1400	475	430	1680	1280	1393	1987
FHF50-200/110A/D197	2	65	Rp 1"	80	385	345	110	895	100	225	410	1400	475	475	1680	1105	1413	2007
FHF50-200/110/D209	2	65	Rp 1"	80	385	345	205	895	100	225	460	1400	475	475	1680	1200	1463	2057
FHF50-250/150/D224	2	65	Rp 1"	80	375	385	280	995	100	225	430	1400	475	475	1710	1375	1458	2052
FHF50-250/185/D237	2	65	Rp 1"	80	400	395	280	995	100	225	480	1550	475	475	1745	1375	1508	2102
FHF50-250/220/D250	2	65	Rp 1"	80	400	395	280	995	100	225	480	1550	475	475	1745	1375	1508	2102
FHF65-125/40/D121	2	80	Rp 1"	100	400	375	240	895	100	225	410	1400	475	430	1680	1235	1465	2072
FHF65-125/55/D129	2	80	Rp 1"	100	400	375	240	925	100	225	410	1400	475	430	1680	1265	1465	2072
FHF65-125/75/D140	2	80	Rp 1"	100	400	375	240	925	100	225	410	1400	475	430	1680	1265	1465	2072
FHF65-160/110A/D161	2	80	Rp 1"	100	365	355	180	995	100	225	410	1400	475	475	1670	1275	1485	2092
FHF65-160/110/D168	2	80	Rp 1"	100	375	385	280	995	100	225	460	1400	475	475	1710	1375	1535	2142
FHF65-160/150/D178	2	80	Rp 1"	100	375	385	280	995	100	225	460	1400	475	475	1710	1375	1535	2142
FHF65-200/150/D187	2	80	Rp 1"	100	375	385	280	995	100	225	430	1400	475	475	1710	1375	1530	2137
FHF65-200/185/D198	2	80	Rp 1"	100	400	395	280	995	100	225	480	1550	475	475	1745	1375	1580	2187
FHF65-200/220/D210	2	80	Rp 1"	100	400	395	280	995	100	225	480	1550	475	475	1745	1375	1580	2187
FHF65-250/220/D220	2	80	Rp 1"	100	400	395	370	980	100	225	460	1550	475	475	1745	1450	1585	2192
FHF65-250/300/D241	2	80	Rp 1"	100	470	435	290	1160	100	195	480	1750	530	490	1925	1550	1605	2212
FHF65-250/370/D258	2	80	Rp 1"	100	470	435	290	1160	100	195	480	1750	530	490	1925	1550	1605	2212
FHF80-160/150/D163	2	100	Rp 1"	125	375	385	280	995	125	225	430	1400	475	475	1710	1400	1614	2234
FHF80-160/185/D173	2	100	Rp 1"	125	400	395	280	995	125	225	480	1550	475	475	1745	1400	1664	2284
FHF80-200/220/D189	2	100	Rp 1"	125	400	395	330	995	125	225	480	1550	475	475	1745	1450	1689	2309
FHF80-200/300/D207	2	100	Rp 1"	125	470	435	300	1125	125	195	480	1750	530	490	1925	1550	1689	2309
FHF80-250/370/D225	2	100	Rp 1"	125	470	435	280	1160	125	195	480	1750	530	490	1925	1565	1719	2339
FHF80-250/450/D238	2	100	Rp 1"	125	470	395	320	1205	125	195	485	1940	530	490	1885	1650	1724	2344
FHF80-250/550/D256	2	100	Rp 1"	125	485	455	355	1270	125	215	530	1960	530	530	2000	1750	1769	2389

 Dimensions in mm. Tolerance ± 10 mm.

gen11d_fhf-en_g_td

**GEN..11D/FHF 100-125 SERIES
FIRE-FIGHTING BOOSTER SETS EN 12845**

GEN..D/FHF

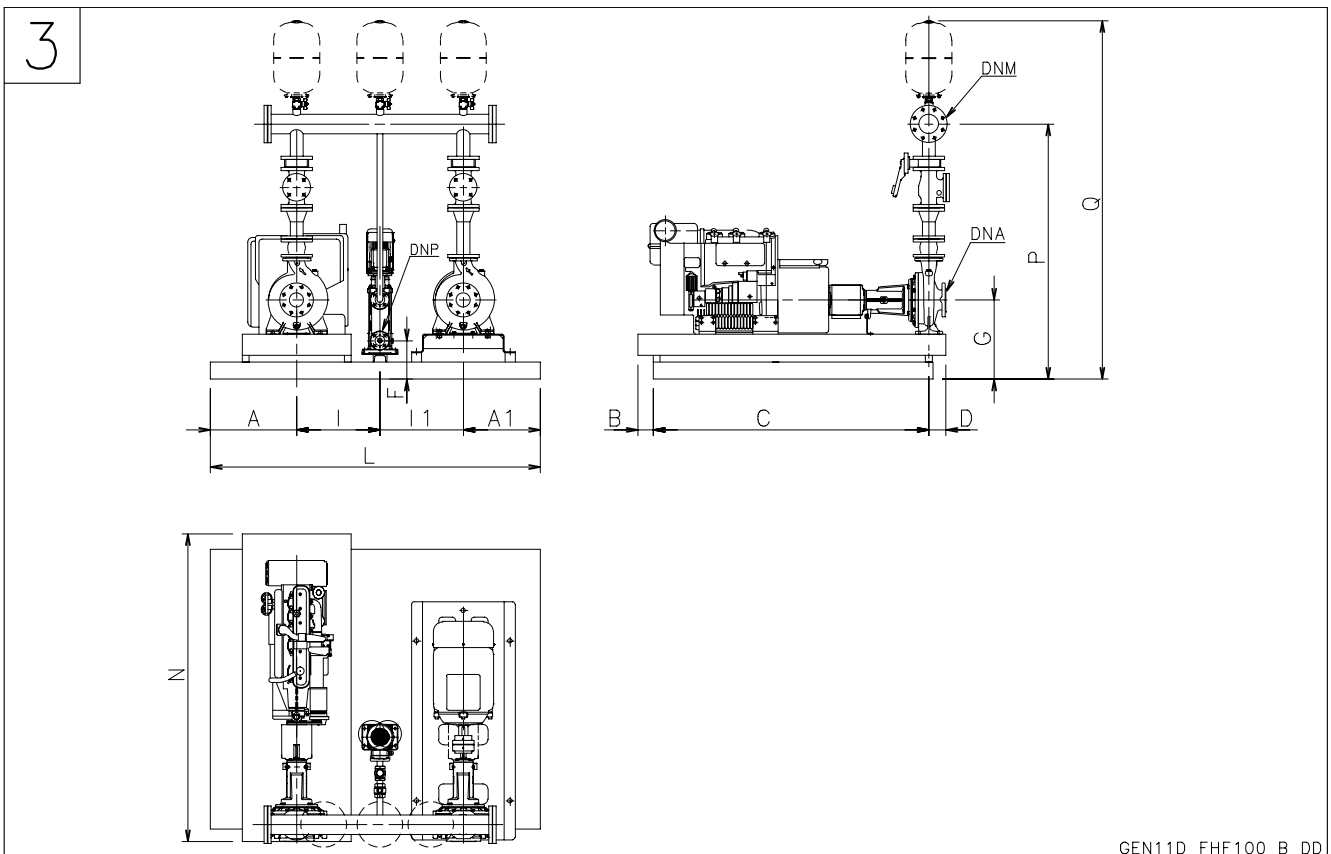
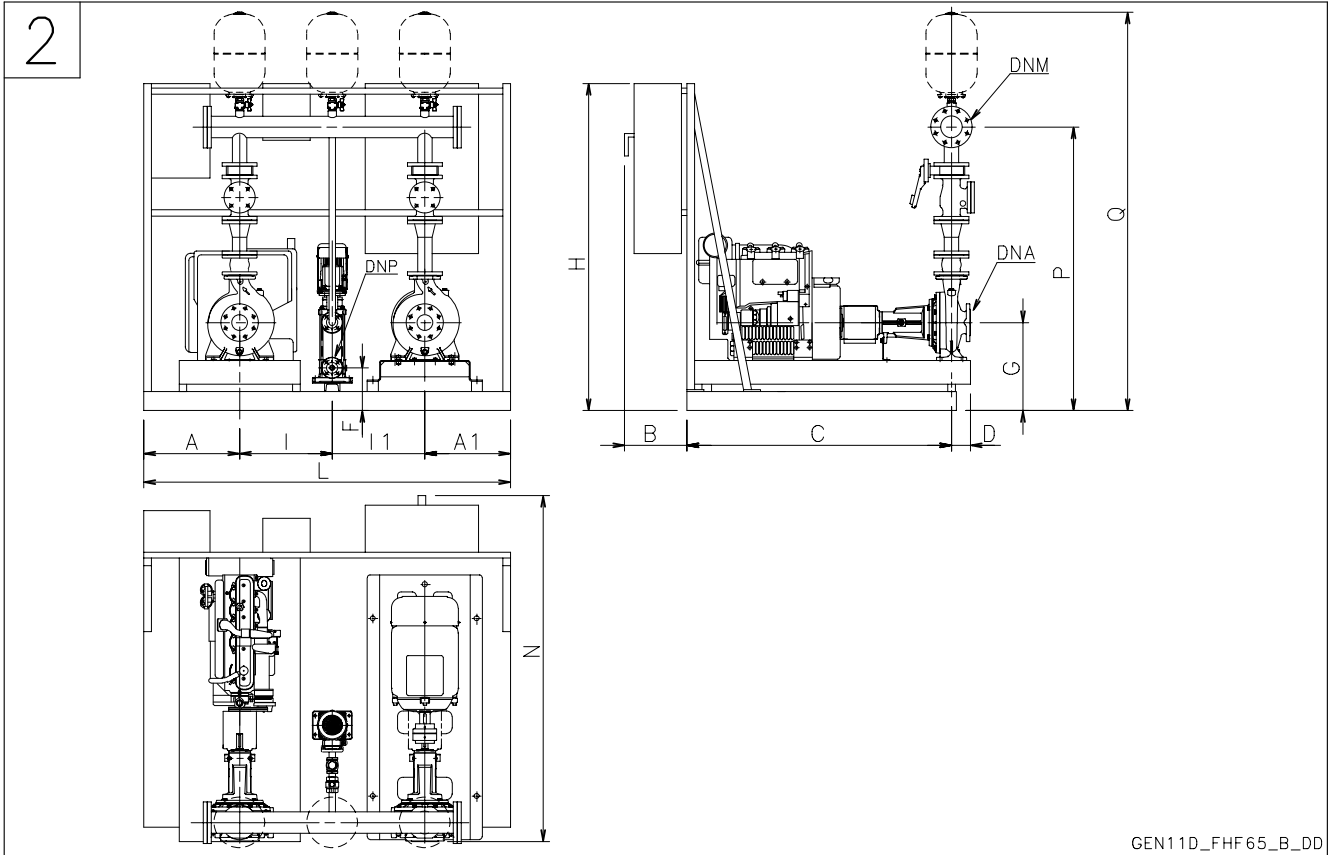

For the overall dimensions of the fuel tank and the starting batteries, see tables on pages 20-25.

GEN..11D/FHF 100-125 SERIES FIRE-FIGHTING BOOSTER SETS EN 12845

GEN..11D	DRW N°	DNA	DNP	DNM	A	A1	B	C	D	F	G	H	I	I1	L	N	P	Q
FHF100-160/185/D150	2	125	Rp 1"	150	400	395	265	1020	125	225	448	1550	475	475	1745	1410	1787	2421
FHF100-160/220/D165	2	125	Rp 1"	150	400	395	340	985	125	225	498	1550	475	475	1745	1450	1837	2471
FHF100-160/300/D185	2	125	Rp 1"	200	470	395	280	1175	125	195	468	1750	530	490	1885	1580	1833	2492
FHF100-200/185/D168	2	125	Rp 1"	150	400	395	300	1025	125	225	473	1550	475	475	1745	1450	1812	2446
FHF100-200/300/D192	2	125	Rp 1"	150	470	395	265	1175	125	195	493	1750	530	490	1885	1565	1832	2466
FHF100-200/370/D203	2	125	Rp 1"	150	470	395	280	1225	125	195	493	1750	530	490	1885	1630	1832	2466
FHF100-200/450/D213	2	125	Rp 1"	200	450	460	320	1405	125	195	488	1750	530	530	1970	1850	1853	2512
FHF100-250/300/D200	2	125	Rp 1"	150	470	395	320	1225	140	195	468	1750	530	490	1885	1685	1807	2441
FHF100-250/450/D221	2	125	Rp 1"	200	470	395	320	1225	140	195	468	1750	530	490	1885	1685	1833	2492
FHF100-250/550/D235	2	125	Rp 1"	200	450	460	320	1405	140	195	513	1750	530	530	1970	1865	1878	2537
FHF100-250/750/D254	3	125	Rp 1"	200	550	545	570	1340	140	215	513	\	570	570	2235	2050	1878	2537
FHF100-250/900/D267	3	125	Rp 1"	200	550	545	570	1340	140	215	513	\	570	570	2235	2050	1878	2537
FHF125-200/300/D180	2	150	Rp 1"	200	470	395	360	1150	140	200	493	1750	530	490	1885	1650	2011	2670
FHF125-200/450/D206	2	150	Rp 1"	200	450	460	320	1405	140	200	463	1750	530	530	1970	1865	1981	2640
FHF125-200/550/D216	2	150	Rp 1"	200	450	460	320	1405	140	200	513	1940	530	530	1970	1865	2031	2690
FHF125-270/750/D223	3	150	Rp 1"	250	550	555	545	1415	140	220	563	\	570	570	2245	2100	2148	2834
FHF125-270/900/D237	3	150	Rp 1"	250	550	555	620	1340	140	220	563	\	570	570	2245	2100	2148	2834
FHF125-270/1100/D253	3	150	Rp 1"	250	600	615	642	1340	140	220	618	\	620	640	2475	2122	2203	2889
FHF125-270/1320/D266	3	150	Rp 1"	250	600	615	642	1340	140	220	618	\	620	640	2475	2122	2203	2889

Dimensions in mm. Tolerance \pm 10 mm.

gen11d_fhf100-en_f_td

GEN..D/FHF SERIES OF BOOSTER SETS (POSITIVE SUCTION HEAD) H_c PRESSURE DROP CURVE IN SUCTION KIT

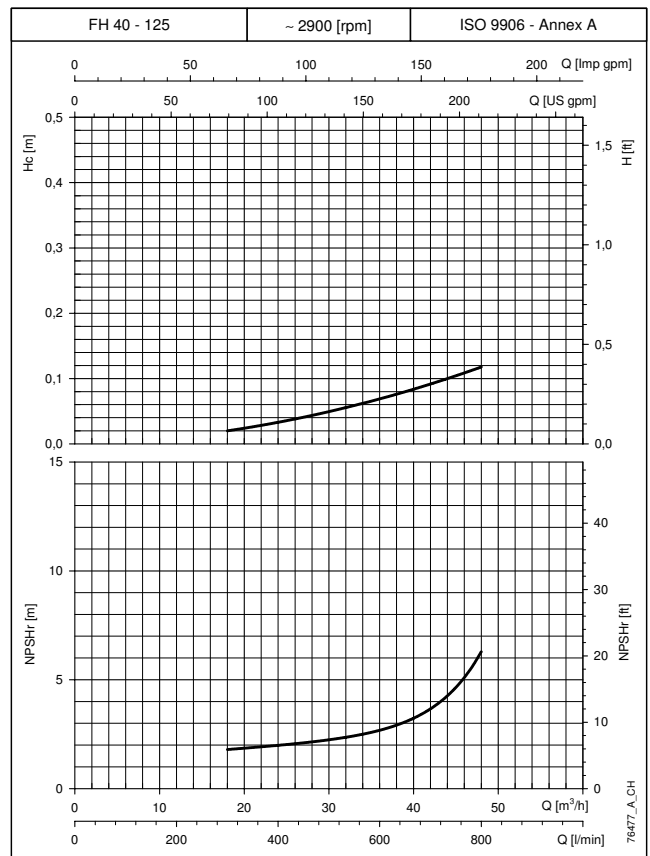
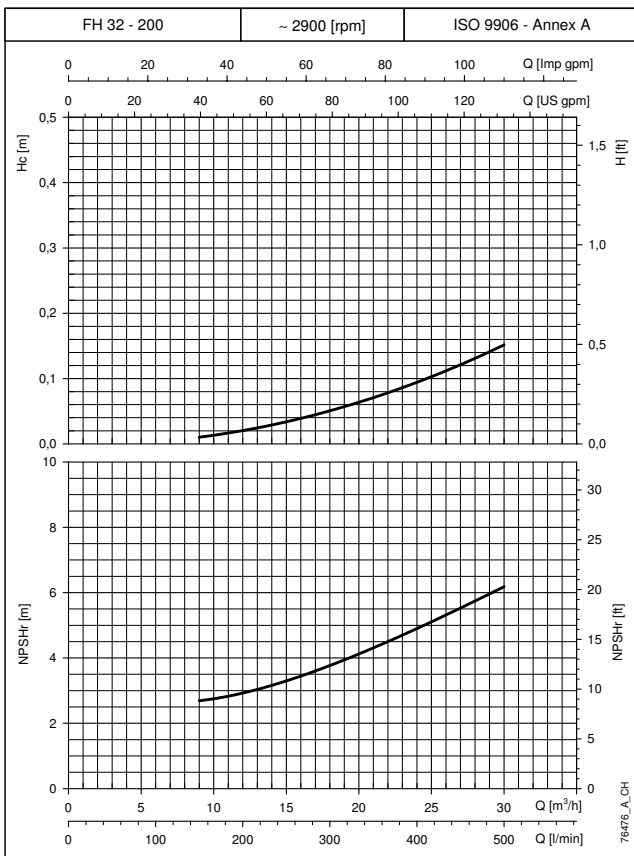
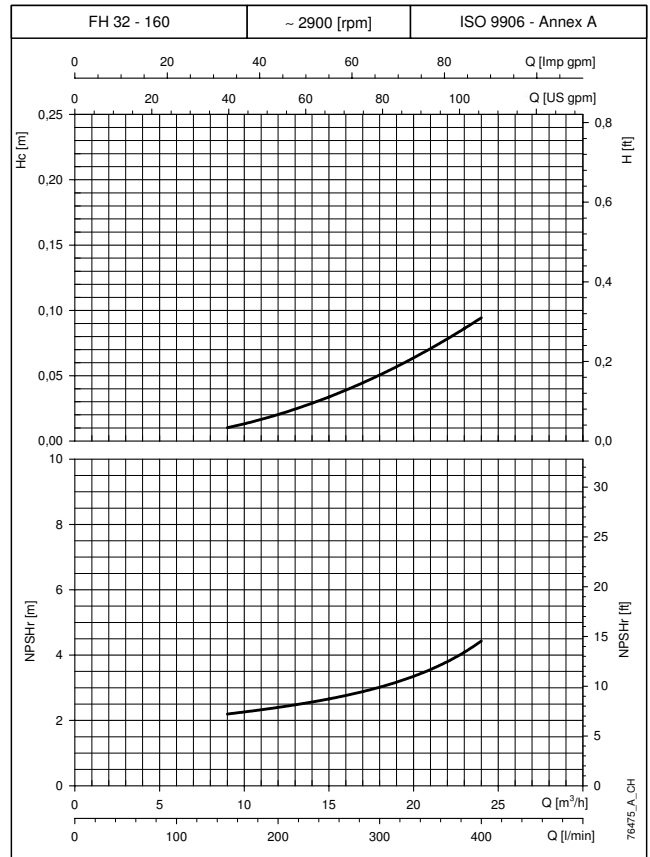
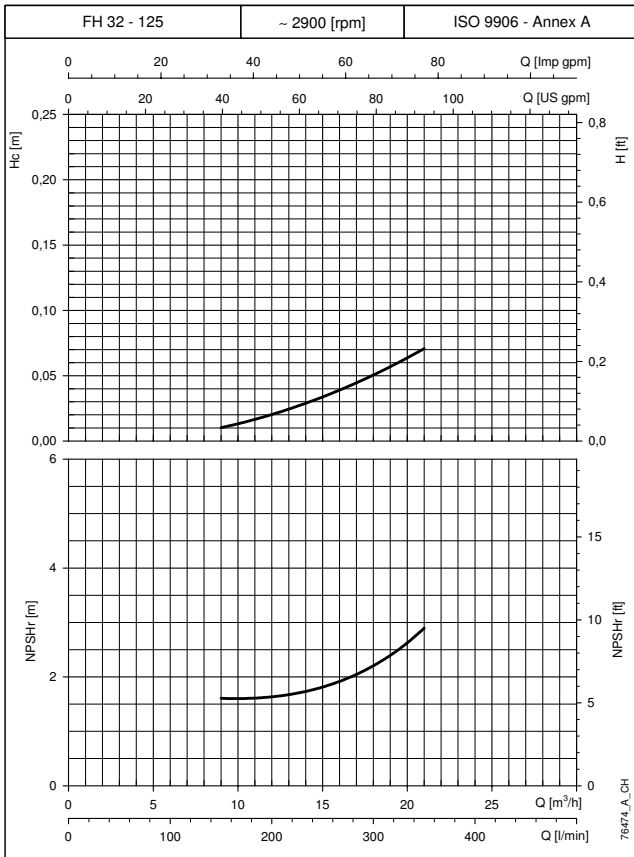

GEN..D/FHF

The declared performance value are valid for liquids with density $\rho = 1.0 \text{ Kg/dm}^3$ and kinematic viscosity $\nu = 1 \text{ mm}^2/\text{sec}$.
The NPSHr values required for the service pump were obtained in the laboratory. When using them for EN 12845 for fire-fighting systems, increase the value by 1 m.
H_c: Pressure drop curve in suction kit.

**GEN..D/FHF SERIES OF BOOSTER SETS (POSITIVE SUCTION HEAD)
H_c PRESSURE DROP CURVE IN SUCTION KIT**

GEN..D/FHF

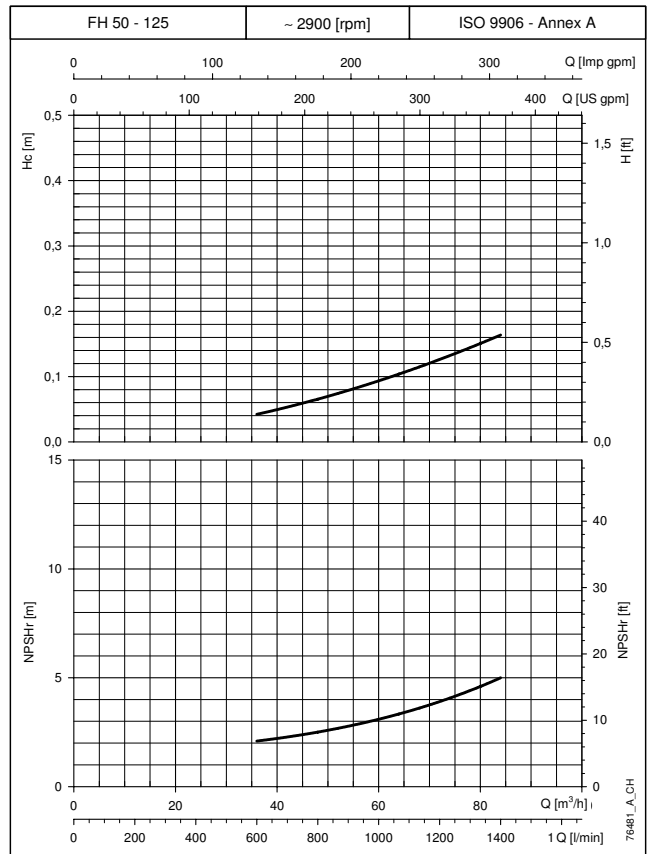
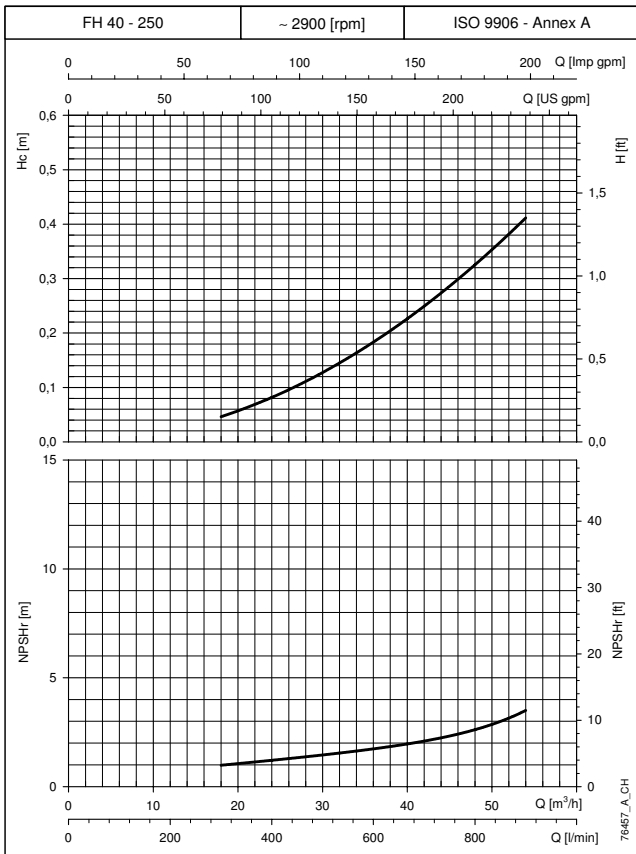
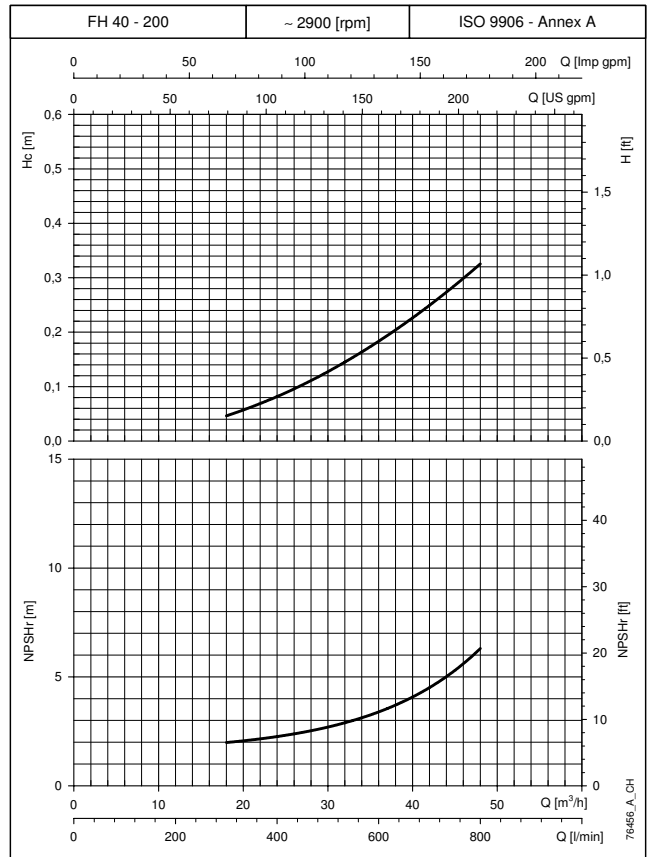
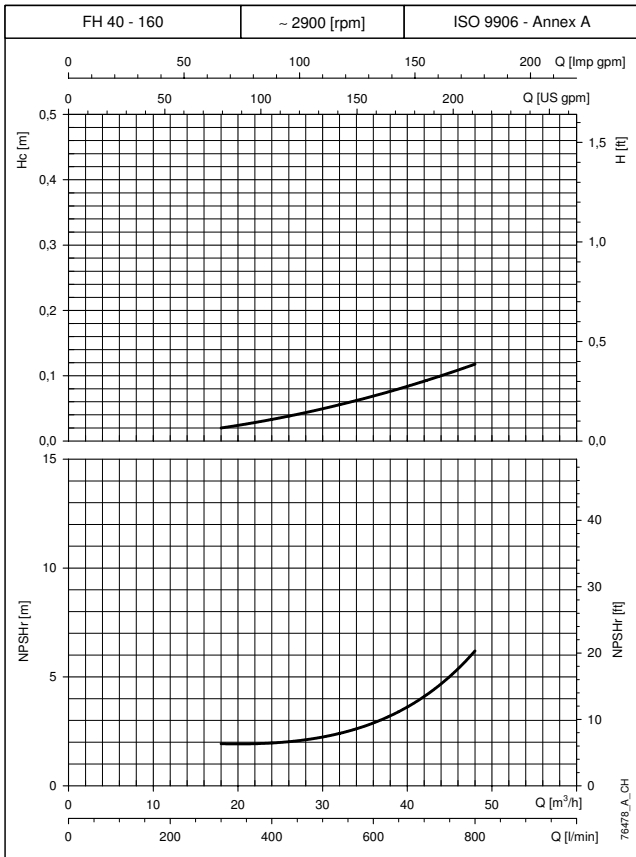

The declared performance value are valid for liquids with density $\rho = 1.0 \text{ Kg/dm}^3$ and kinematic viscosity $\nu = 1 \text{ mm}^2/\text{sec}$.
The NPSH_r values required for the service pump were obtained in the laboratory. When using them for EN 12845 for fire-fighting systems, increase the value by 1 m.
H_c: Pressure drop curve in suction kit.

GEN..D/FHF SERIES OF BOOSTER SETS (POSITIVE SUCTION HEAD) H_c PRESSURE DROP CURVE IN SUCTION KIT

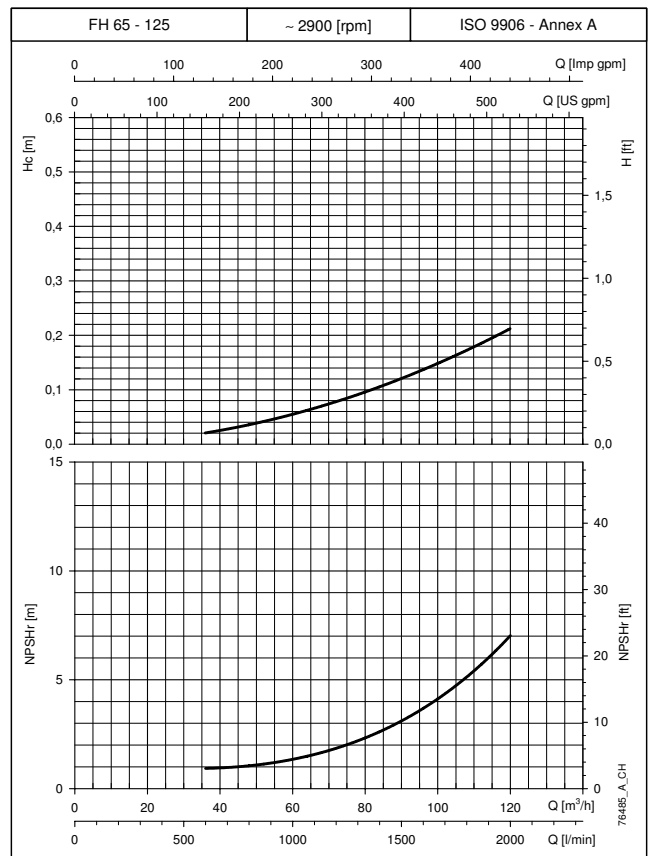
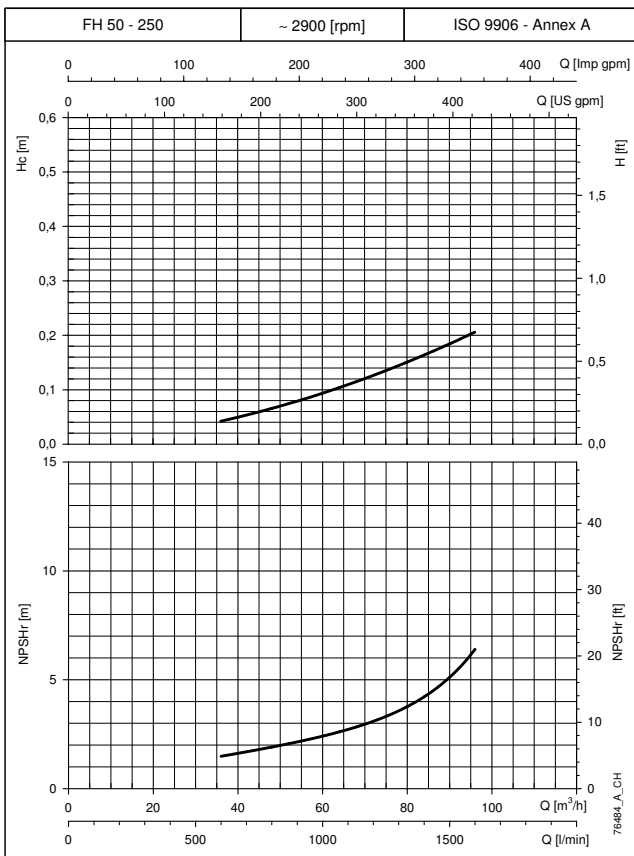
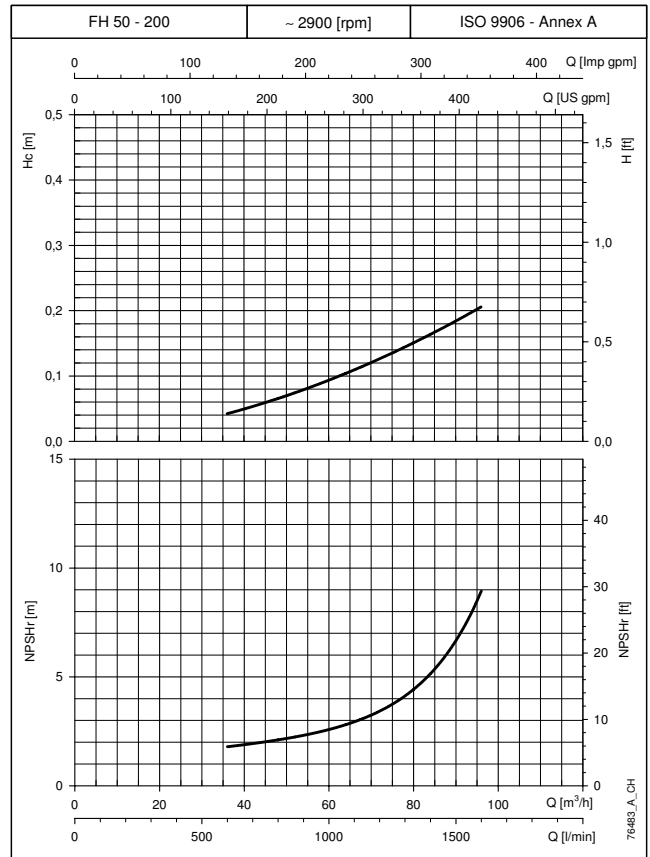
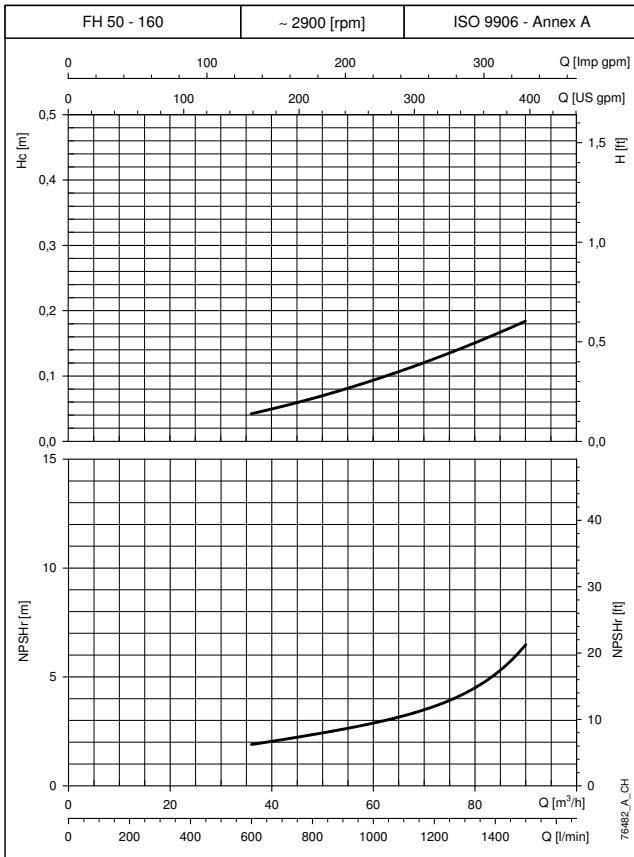

The declared performance value are valid for liquids with density $\rho = 1.0 \text{ Kg/dm}^3$ and kinematic viscosity $\nu = 1 \text{ mm}^2/\text{sec}$.
 The NPSH_r values required for the service pump were obtained in the laboratory. When using them for EN 12845 for fire-fighting systems, increase the value by 1 m.
 H_c: Pressure drop curve in suction kit.

GEN..D/FHF

**GEN..D/FHF SERIES OF BOOSTER SETS (POSITIVE SUCTION HEAD)
H_c PRESSURE DROP CURVE IN SUCTION KIT**

GEN..D/FHF

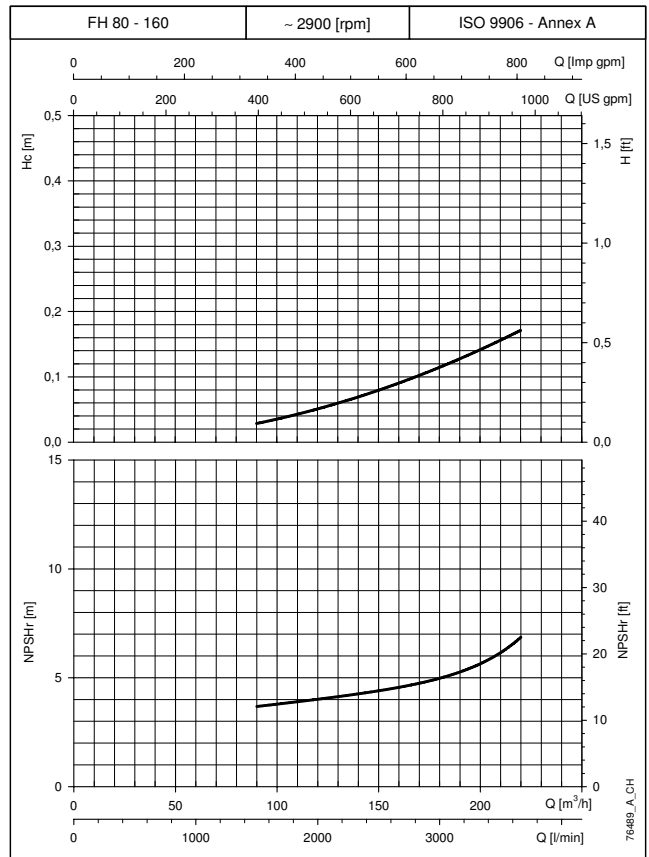
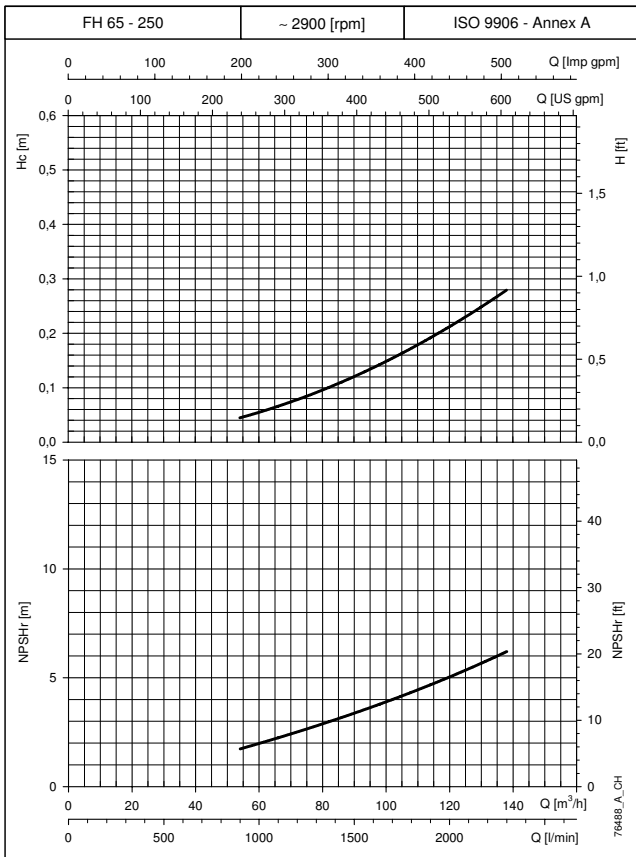
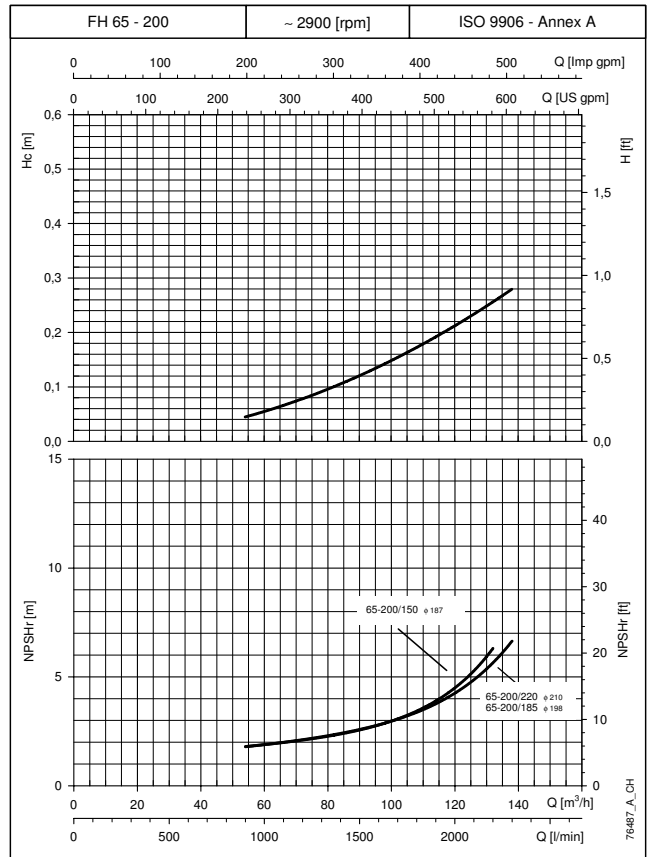
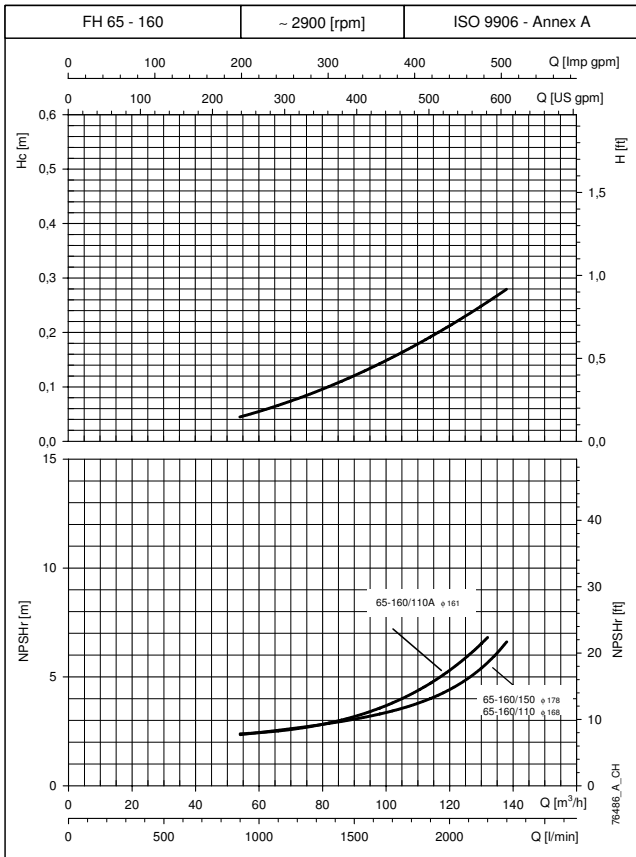

The declared performance value are valid for liquids with density $\rho = 1.0 \text{ Kg/dm}^3$ and kinematic viscosity $\nu = 1 \text{ mm}^2/\text{sec}$.
The NPSHr values required for the service pump were obtained in the laboratory. When using them for EN 12845 for fire-fighting systems, increase the value by 1 m.
H_c: Pressure drop curve in suction kit.

GEN..D/FHF SERIES OF BOOSTER SETS (POSITIVE SUCTION HEAD) H_c PRESSURE DROP CURVE IN SUCTION KIT

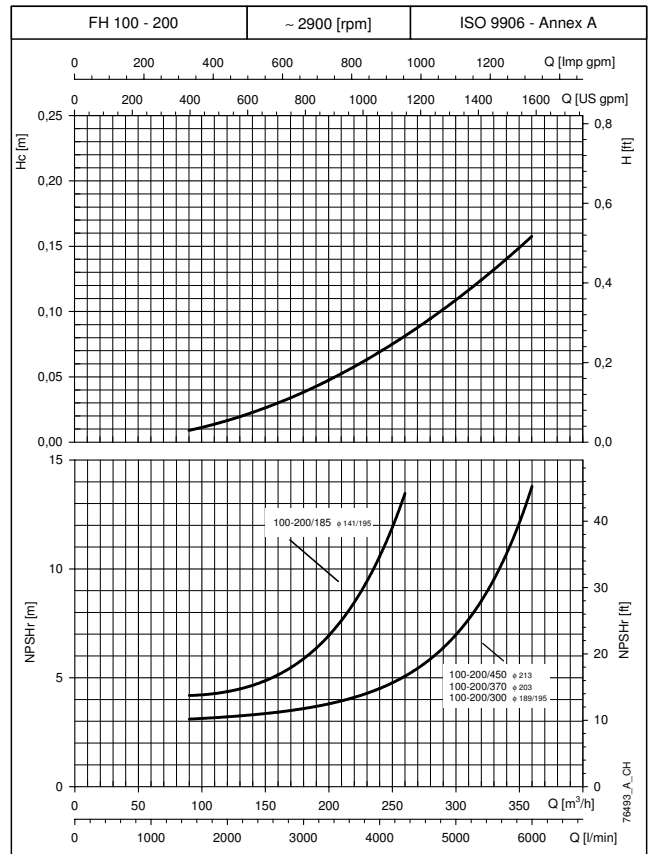
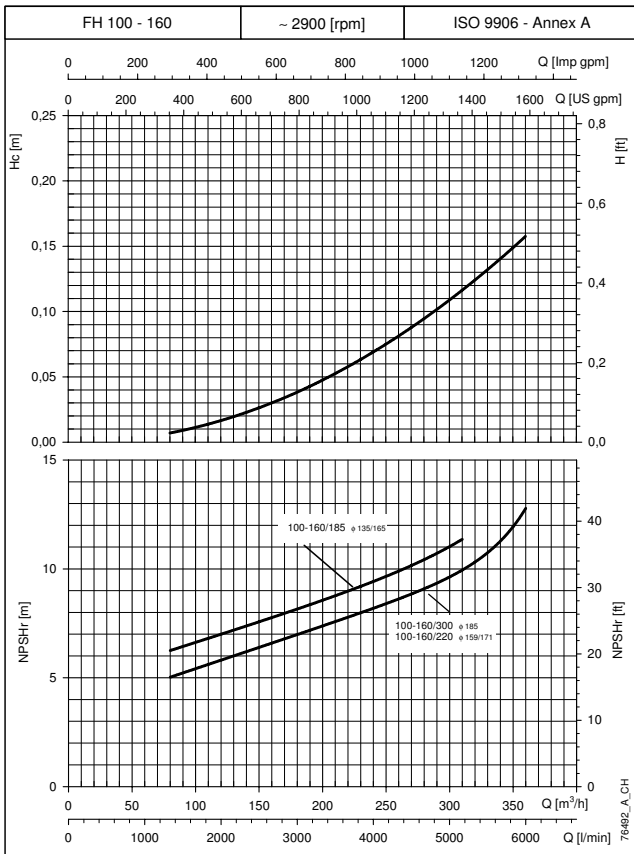
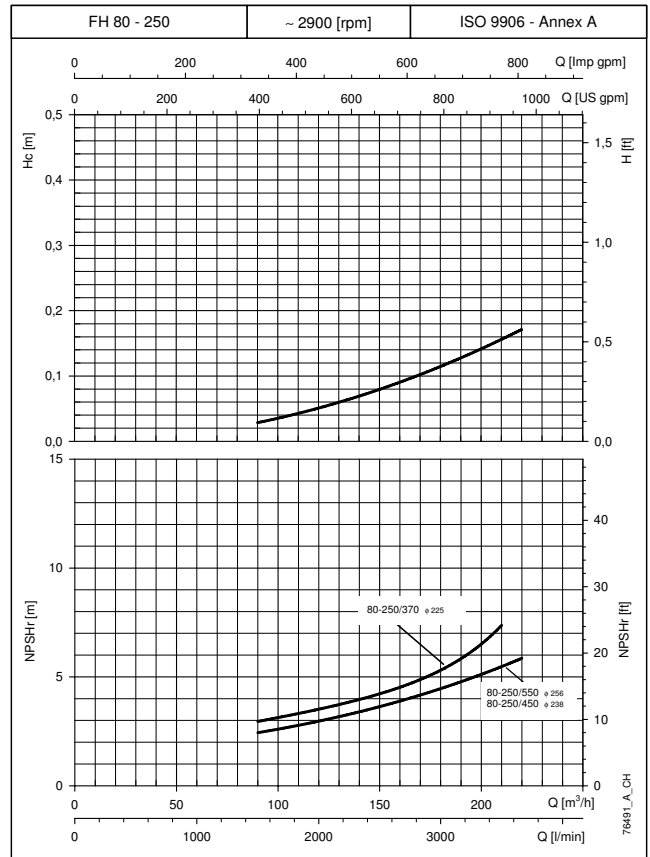
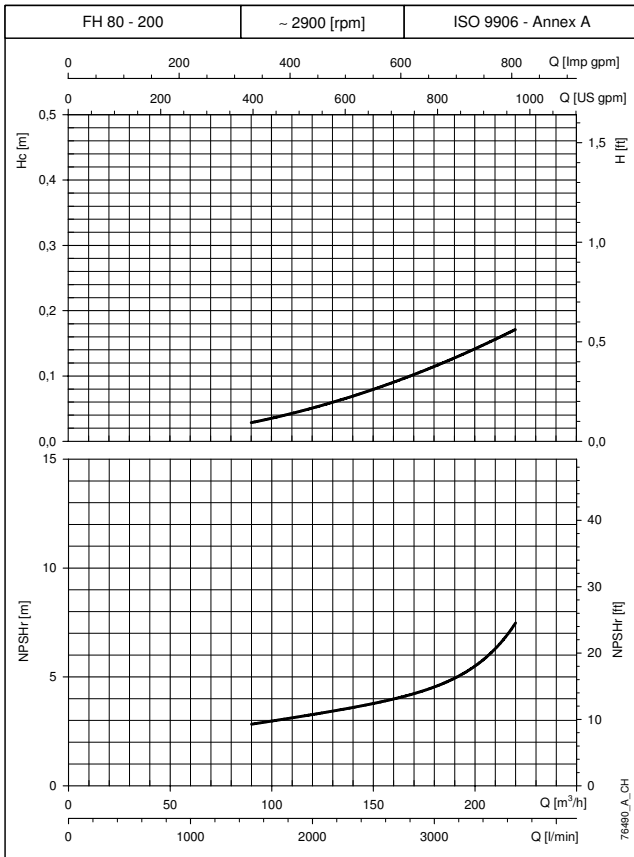

The declared performance value are valid for liquids with density $\rho = 1.0 \text{ Kg/dm}^3$ and kinematic viscosity $\nu = 1 \text{ mm}^2/\text{sec}$.
The NPSHr values required for the service pump were obtained in the laboratory. When using them for EN 12845 for fire-fighting systems, increase the value by 1 m.
H_c: Pressure drop curve in suction kit.

GEN..D/FHF

GEN..D/FHF SERIES OF BOOSTER SETS (POSITIVE SUCTION HEAD) H_c PRESSURE DROP CURVE IN SUCTION KIT

GEN..D/FHF

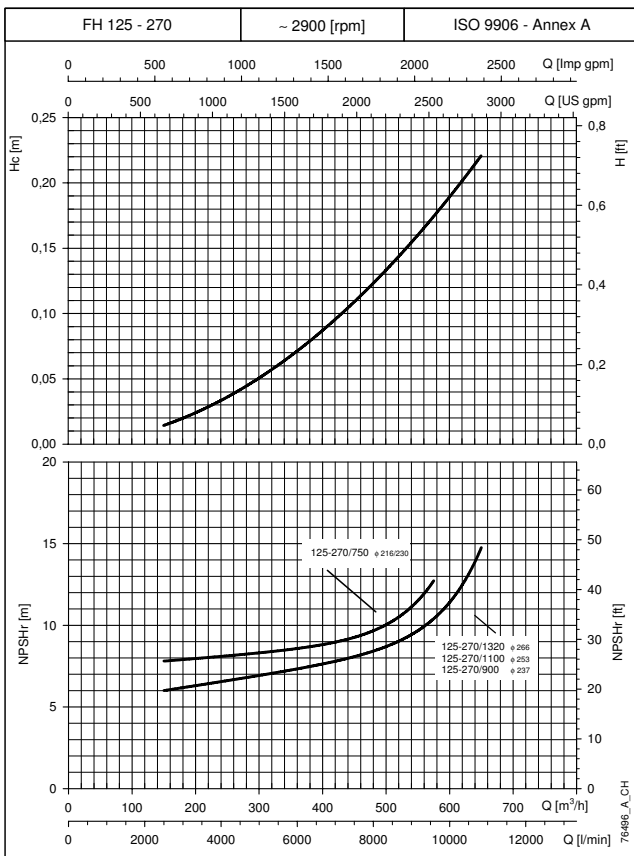
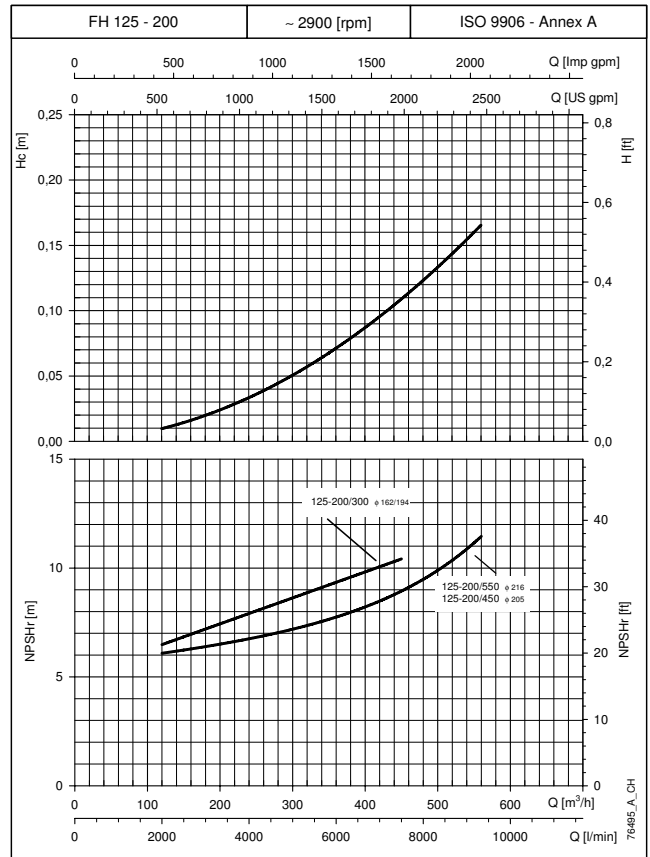
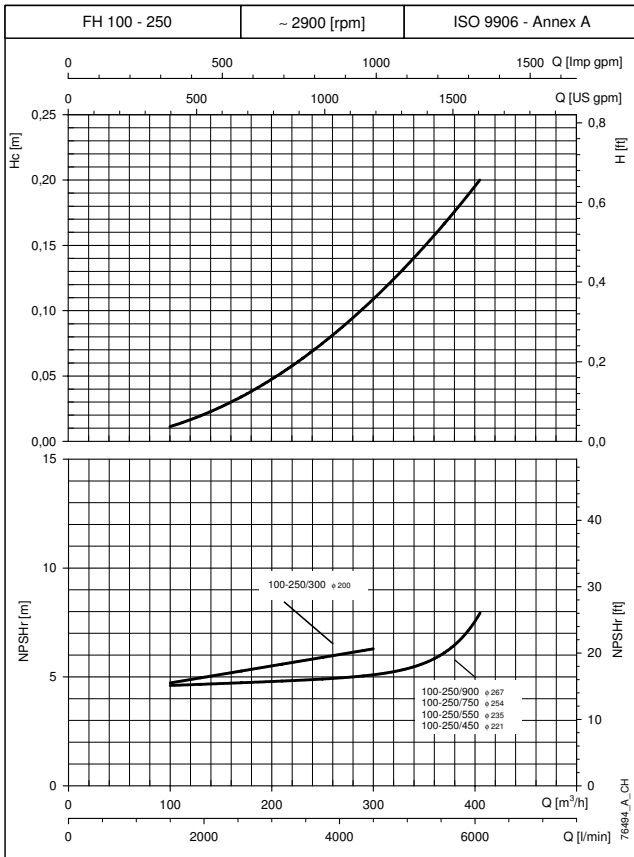

The declared performance value are valid for liquids with density $\rho = 1.0 \text{ Kg/dm}^3$ and kinematic viscosity $\nu = 1 \text{ mm}^2/\text{sec}$.
 The NPSH_r values required for the service pump were obtained in the laboratory. When using them for EN 12845 for fire-fighting systems, increase the value by 1 m.
 H_c: Pressure drop curve in suction kit.

GEN..D/FHF SERIES OF BOOSTER SETS (SUCTION LIFT) H_c PRESSURE DROP CURVE IN SUCTION KIT

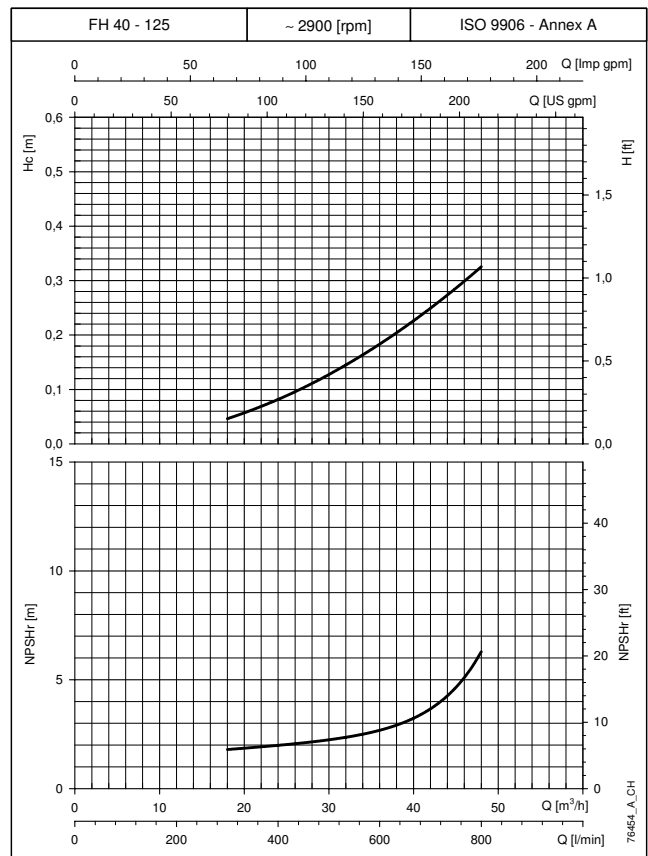
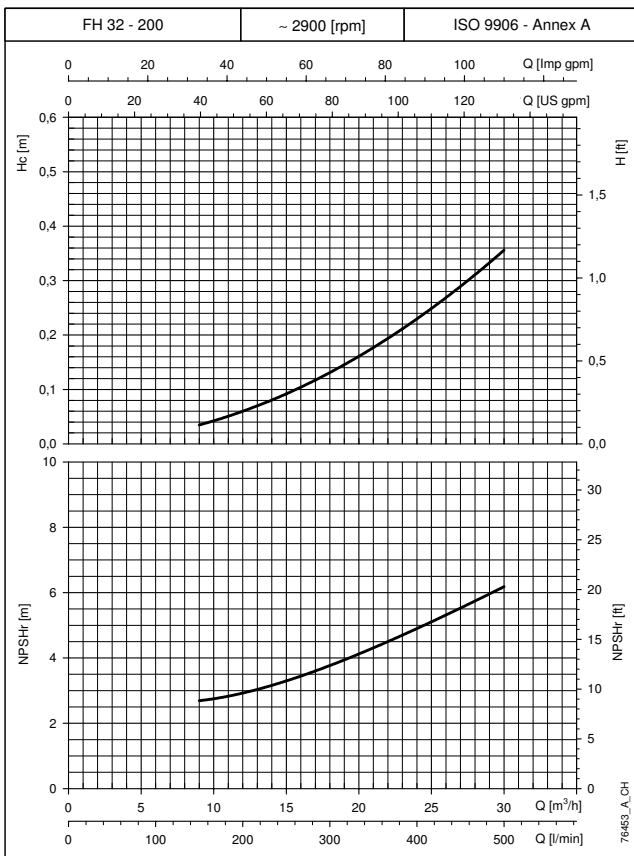
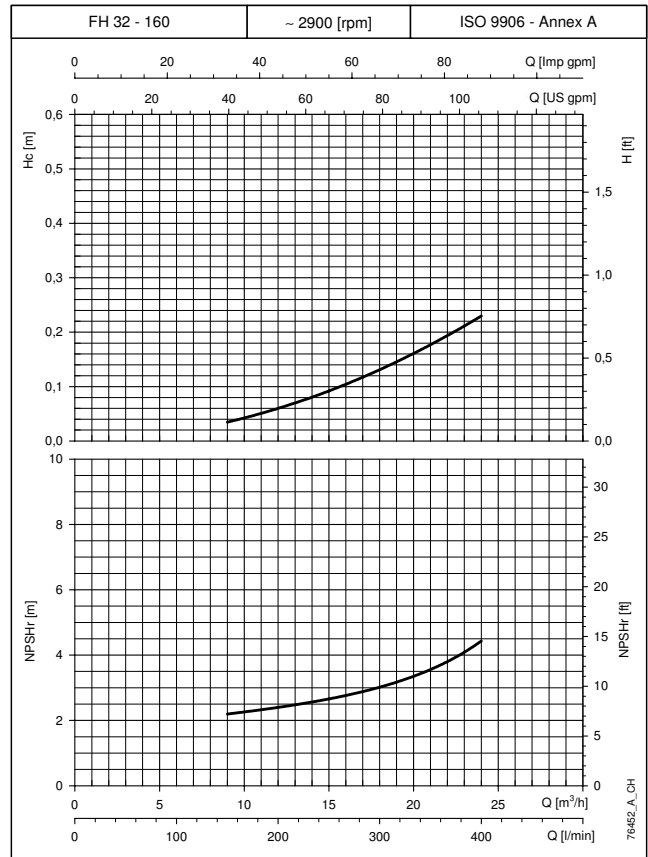
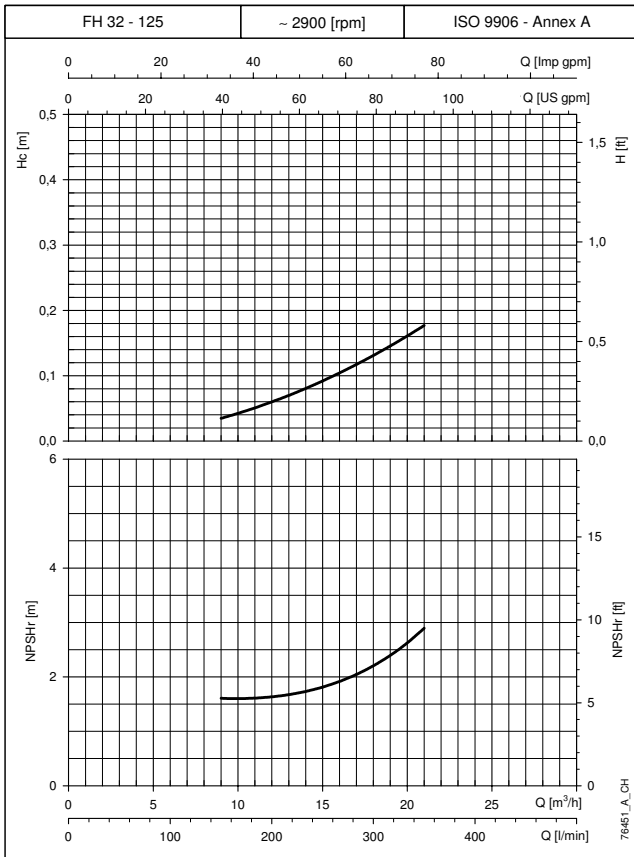

The declared performance value are valid for liquids with density $\rho = 1.0 \text{ Kg/dm}^3$ and kinematic viscosity $\nu = 1 \text{ mm}^2/\text{sec}$.
The NPSHr values required for the service pump were obtained in the laboratory. When using them for EN 12845 for fire-fighting systems, increase the value by 1 m.
H_c: Pressure drop curve in suction kit.

GEN..D/FHF

**GEN..D/FHF SERIES OF BOOSTER SETS (SUCTION LIFT)
H_c PRESSURE DROP CURVE IN SUCTION KIT**

GEN..D/FHF

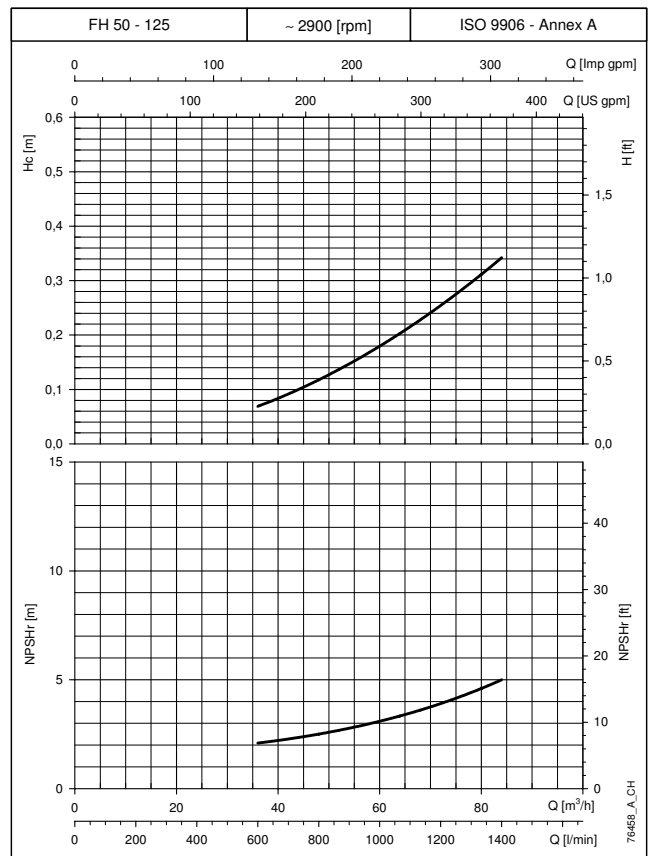
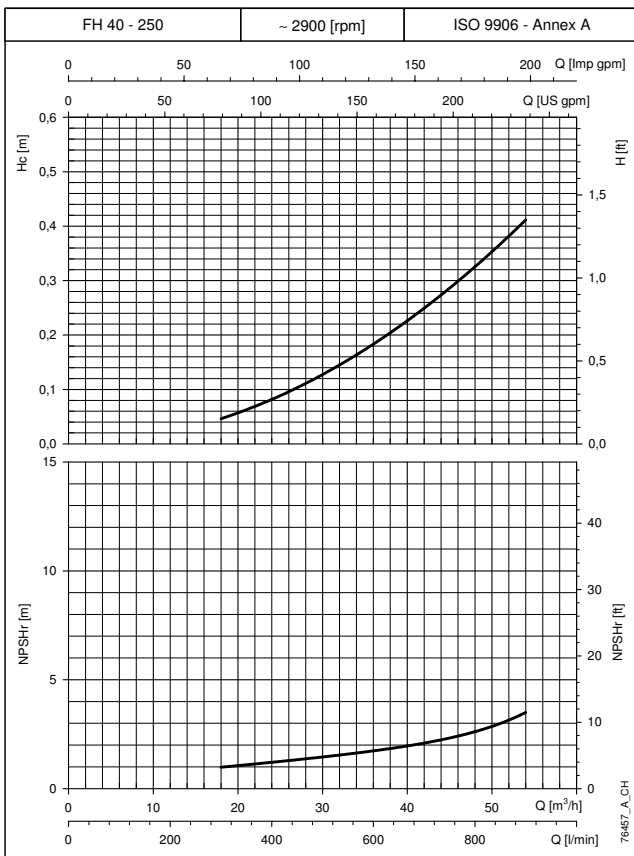
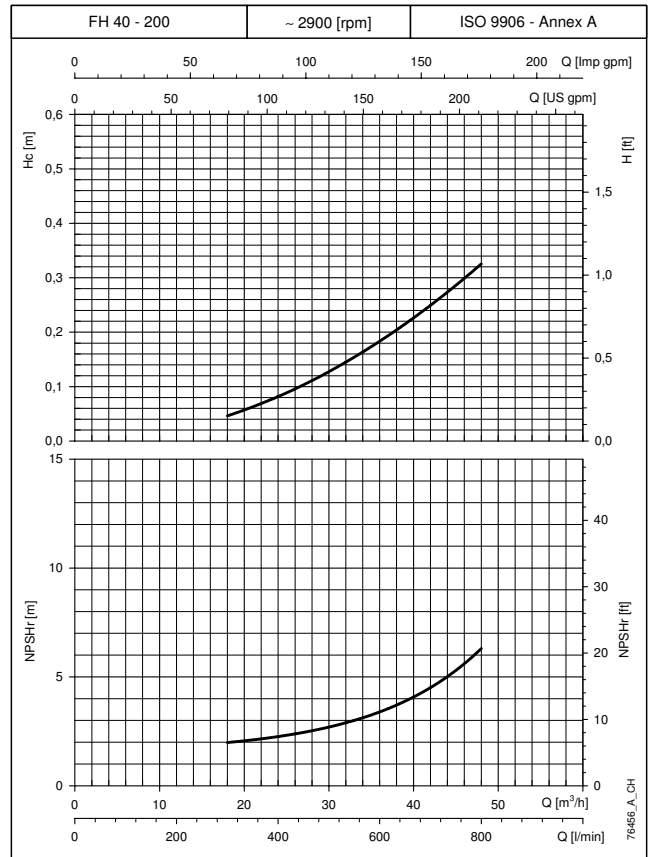
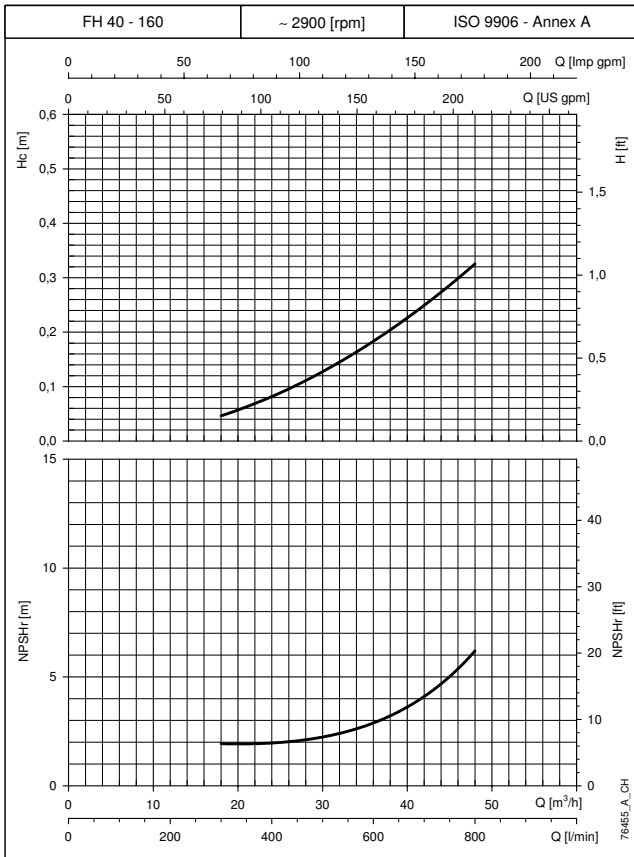

The declared performance value are valid for liquids with density $\rho = 1.0 \text{ Kg/dm}^3$ and kinematic viscosity $\nu = 1 \text{ mm}^2/\text{sec}$.
The NPSHr values required for the service pump were obtained in the laboratory. When using them for EN 12845 for fire-fighting systems, increase the value by 1 m.
H_c: Pressure drop curve in suction kit.

**GEN..D/FHF SERIES OF BOOSTER SETS (SUCTION LIFT)
H_c PRESSURE DROP CURVE IN SUCTION KIT**

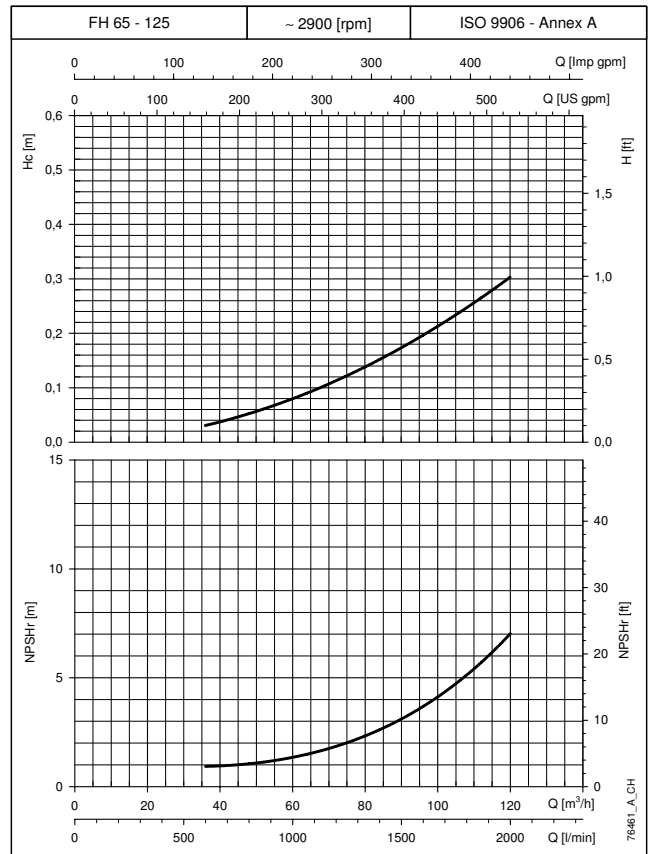
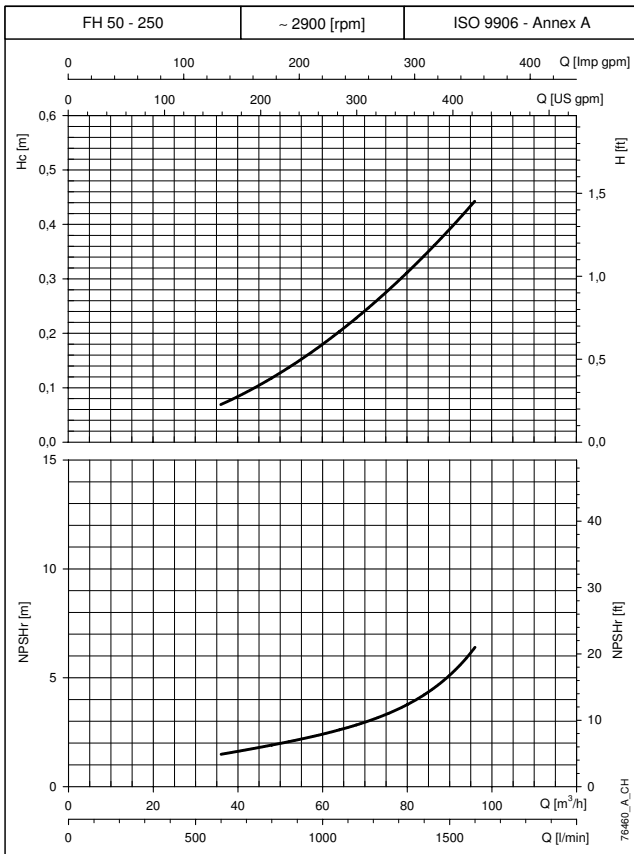
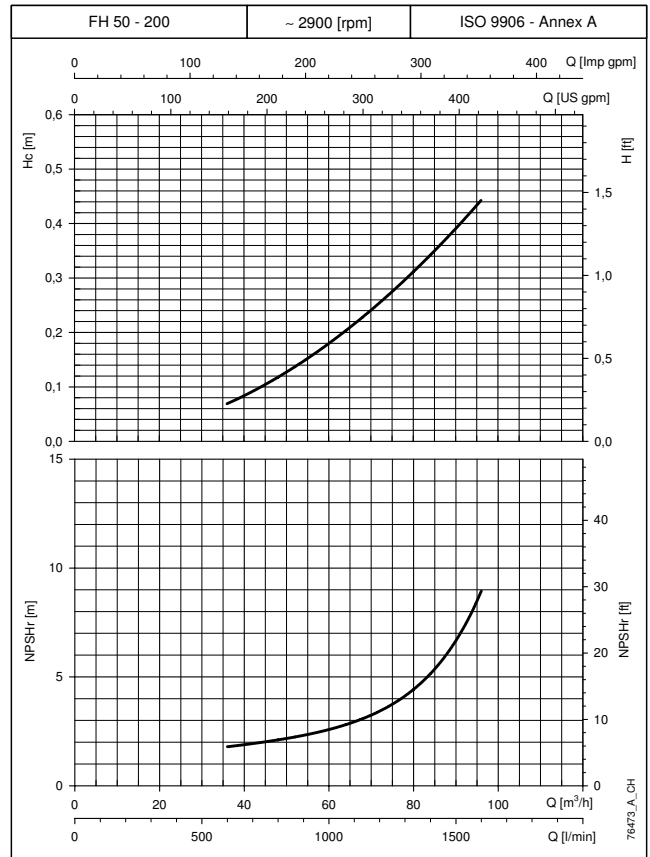
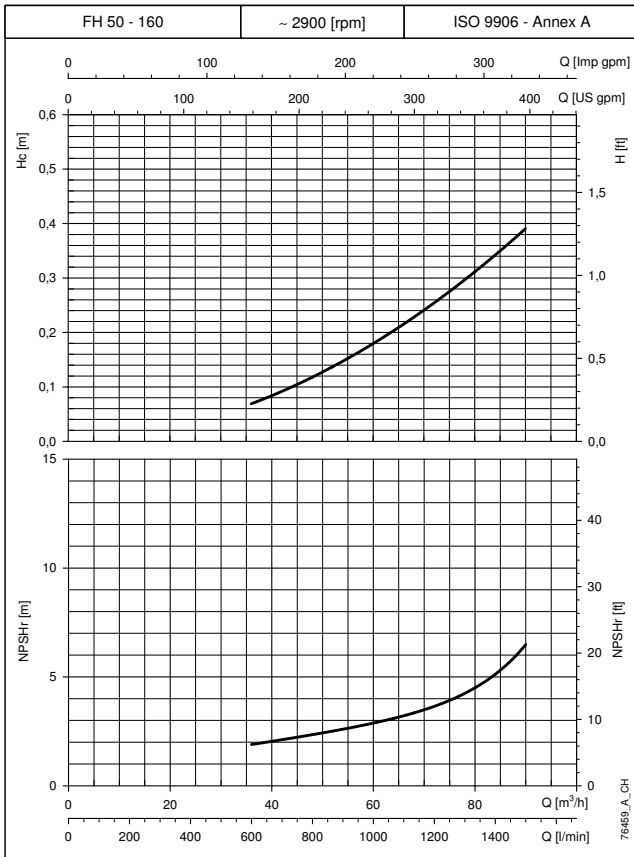

GEN..D/FHF

The declared performance value are valid for liquids with density $\rho = 1.0 \text{ Kg/dm}^3$ and kinematic viscosity $\nu = 1 \text{ mm}^2/\text{sec}$.
The NPSH_r values required for the service pump were obtained in the laboratory. When using them for EN 12845 for fire-fighting systems, increase the value by 1 m.
H_c: Pressure drop curve in suction kit.

GEN..D/FHF SERIES OF BOOSTER SETS (SUCTION LIFT) H_c PRESSURE DROP CURVE IN SUCTION KIT

GEN..D/FHF

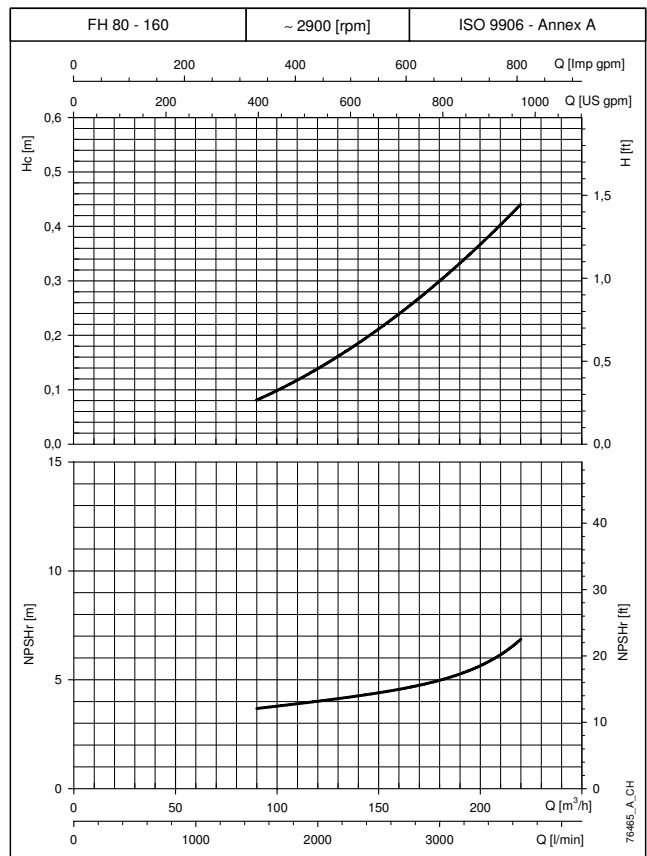
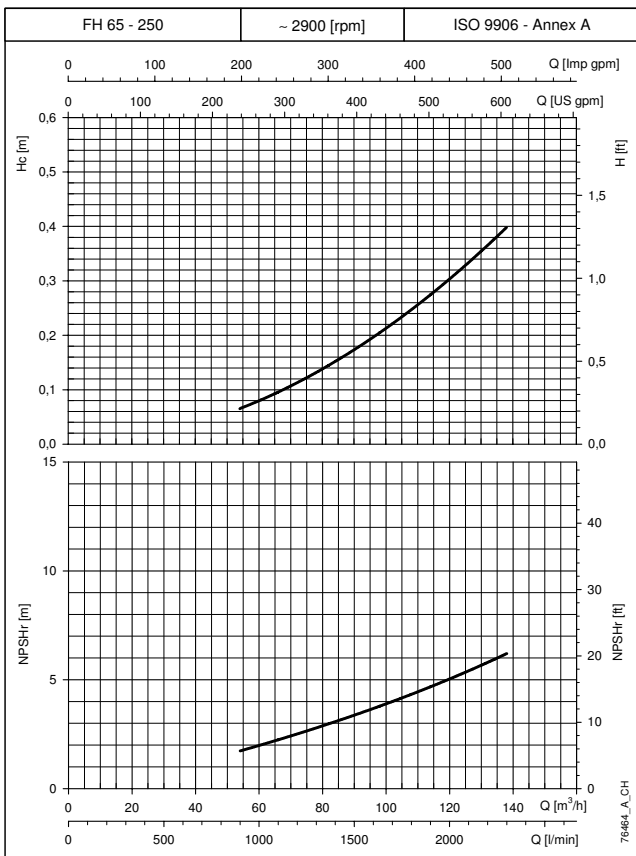
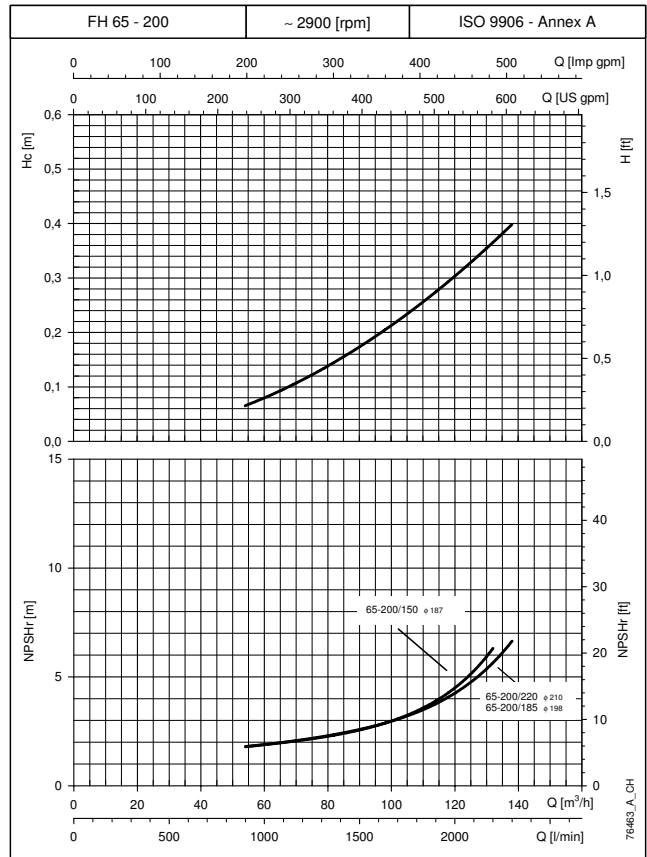
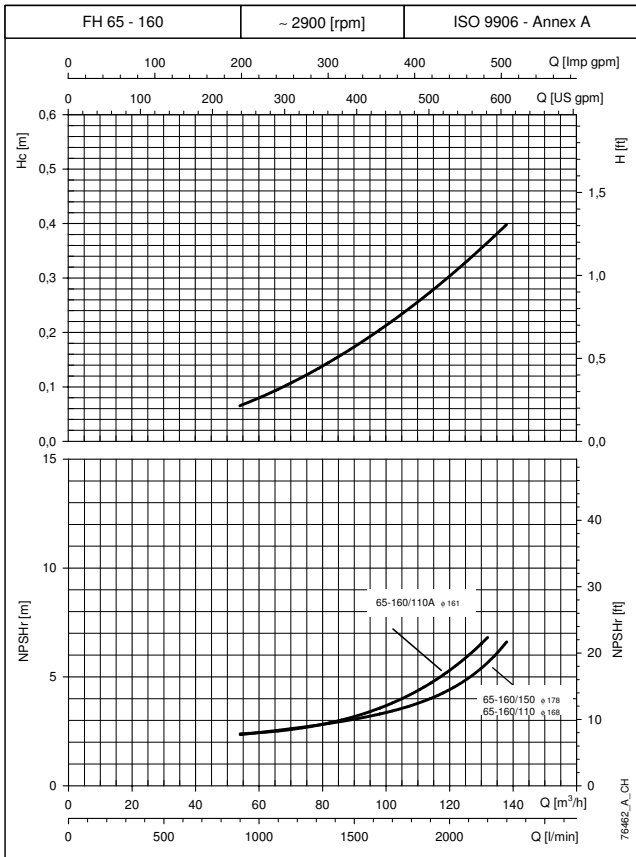

The declared performance value are valid for liquids with density $\rho = 1.0 \text{ Kg/dm}^3$ and kinematic viscosity $\nu = 1 \text{ mm}^2/\text{sec}$.
The NPSHr values required for the service pump were obtained in the laboratory. When using them for EN 12845 for fire-fighting systems, increase the value by 1 m.
H_c: Pressure drop curve in suction kit.

**GEN..D/FHF SERIES OF BOOSTER SETS (SUCTION LIFT)
H_c PRESSURE DROP CURVE IN SUCTION KIT**

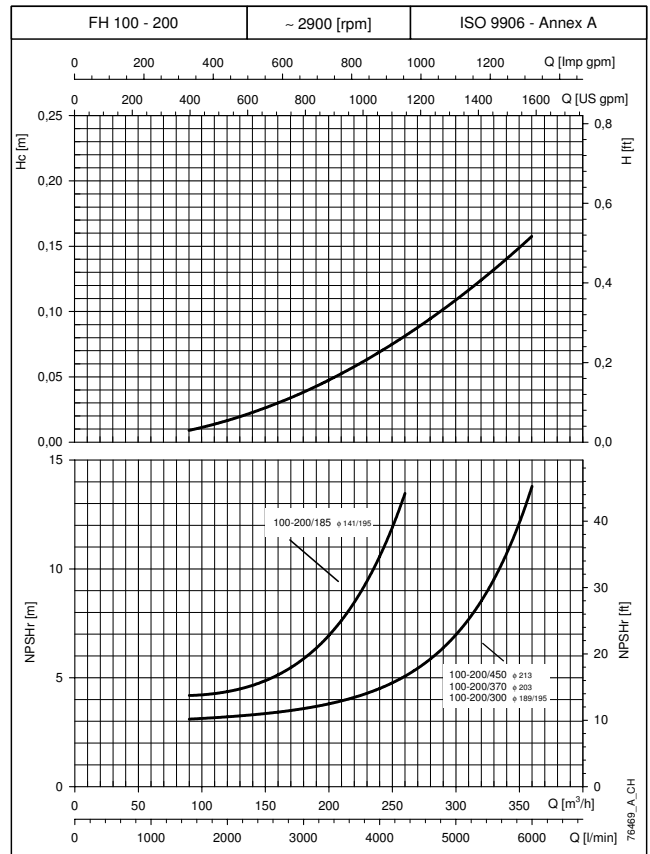
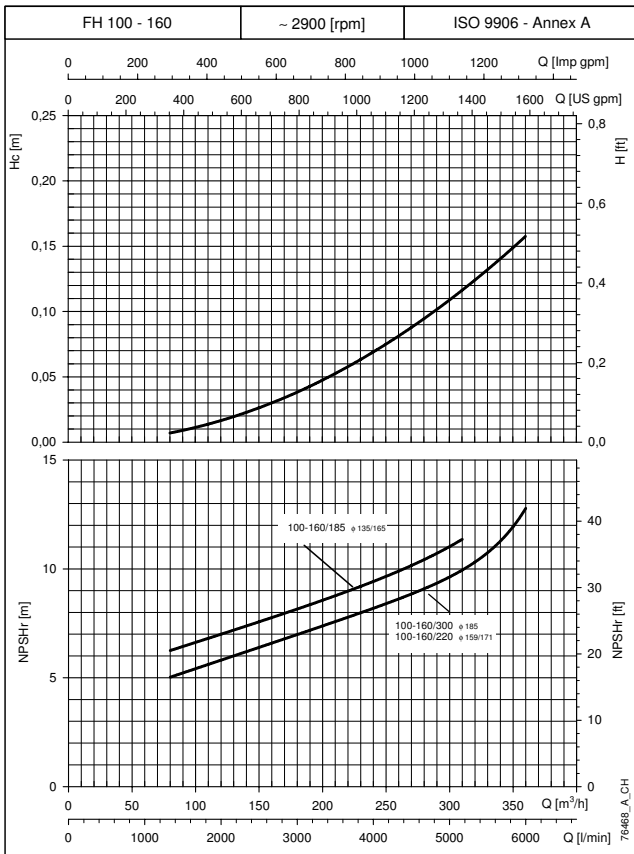
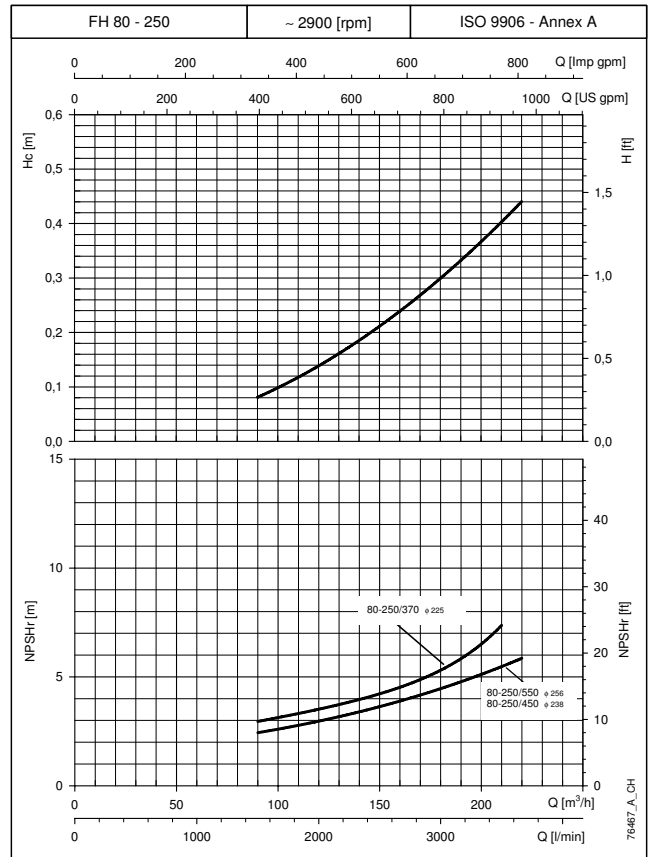
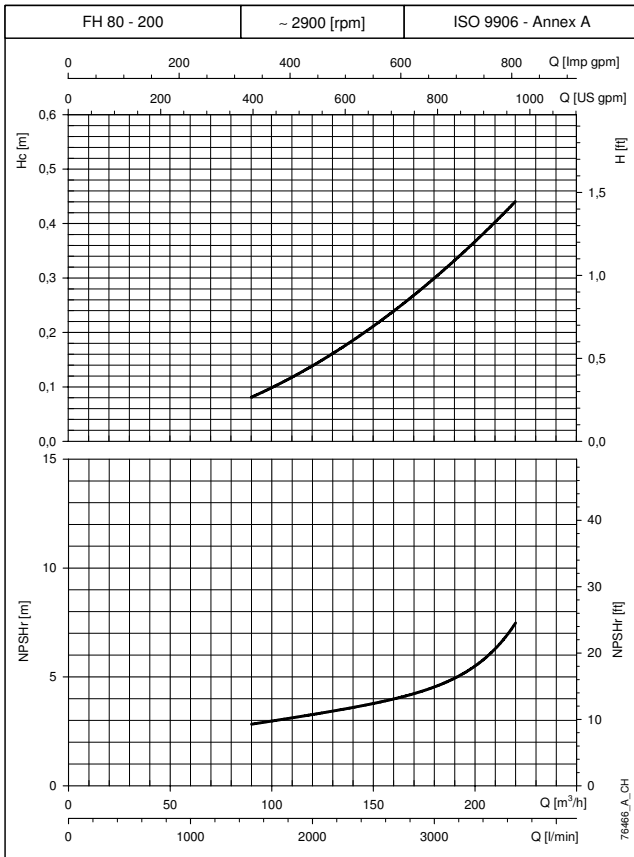

The declared performance value are valid for liquids with density $\rho = 1.0 \text{ Kg/dm}^3$ and kinematic viscosity $\nu = 1 \text{ mm}^2/\text{sec}$.
The NPSHr values required for the service pump were obtained in the laboratory. When using them for EN 12845 for fire-fighting systems, increase the value by 1 m.
H_c: Pressure drop curve in suction kit.

GEN..D/FHF

**GEN..D/FHF SERIES OF BOOSTER SETS (SUCTION LIFT)
H_c PRESSURE DROP CURVE IN SUCTION KIT**

GEN..D/FHF

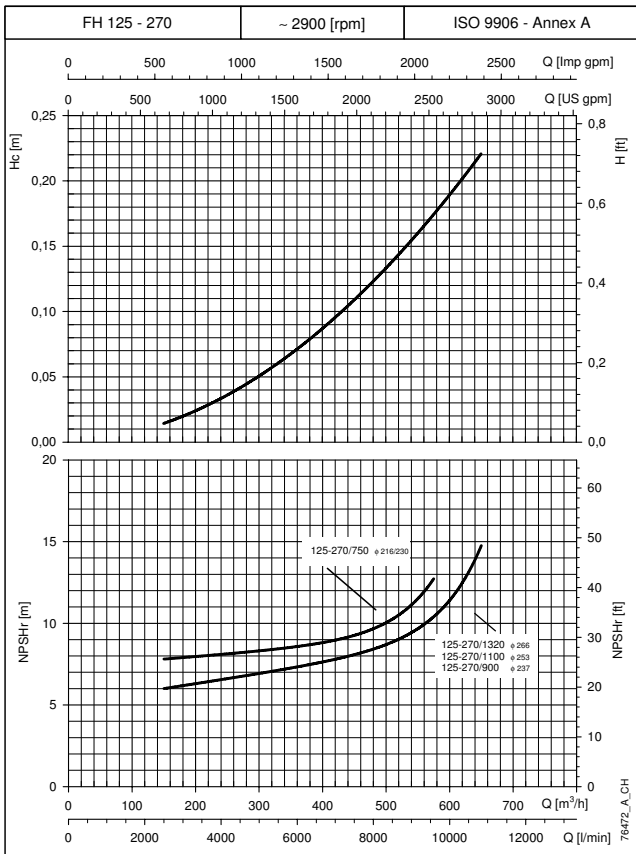
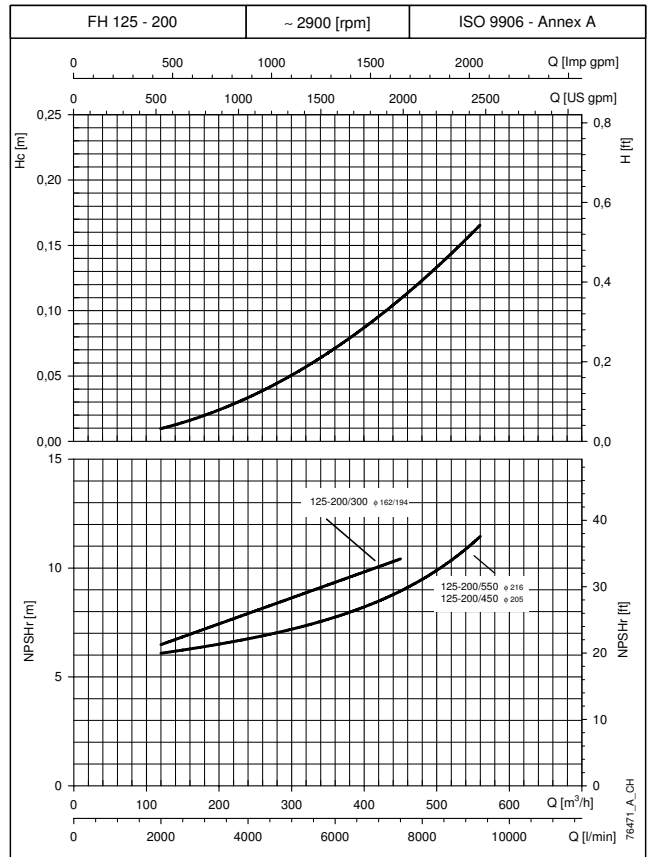
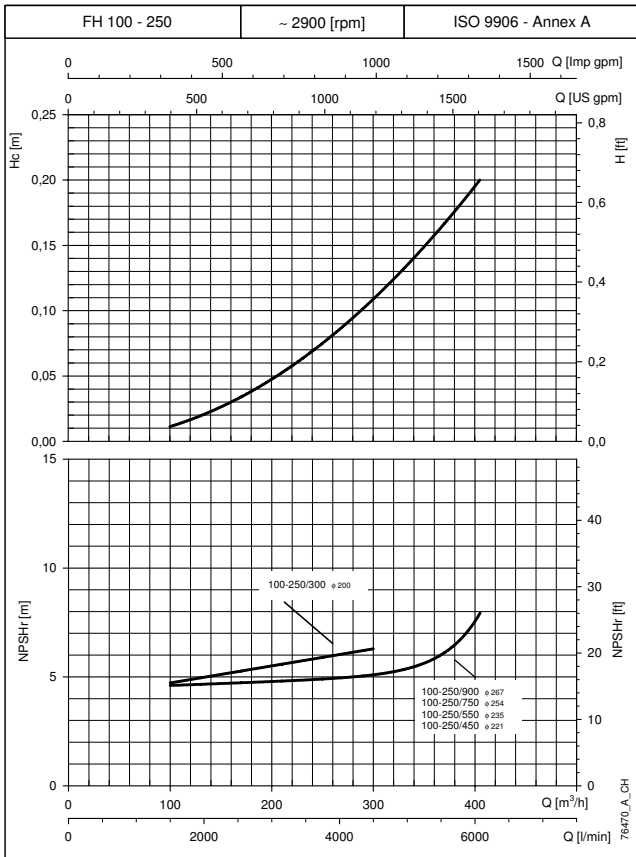

The declared performance value are valid for liquids with density $\rho = 1.0 \text{ Kg/dm}^3$ and kinematic viscosity $\nu = 1 \text{ mm}^2/\text{sec}$.
The NPSH_r values required for the service pump were obtained in the laboratory. When using them for EN 12845 for fire-fighting systems, increase the value by 1 m.
H_c: Pressure drop curve in suction kit.

GEN..D/SHF Series

Fire-fighting booster sets EN 12845,
electric pumps SHF series with high efficiency
motors and diesel engine pumps

50 Hz

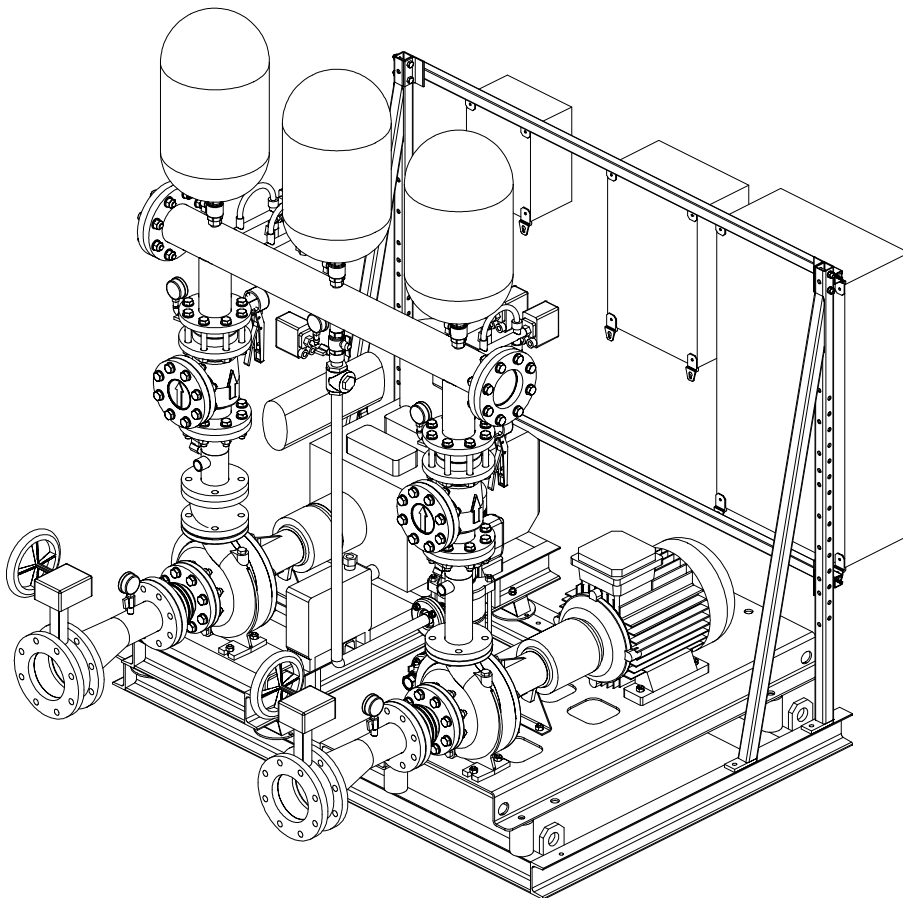

GEN..D/SHF

RANGE

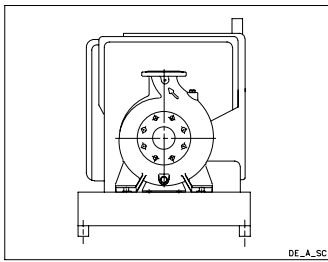

DE_A_SC

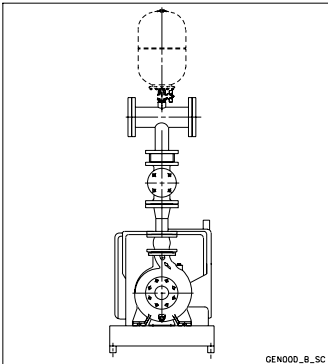

GEN000_B_SC

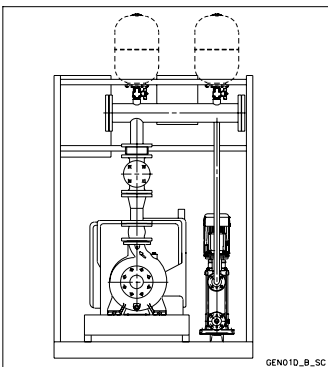

GEN010_B_SC

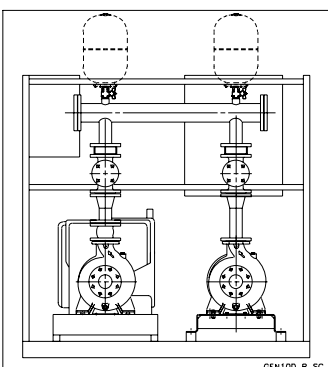

GEN100_B_SC

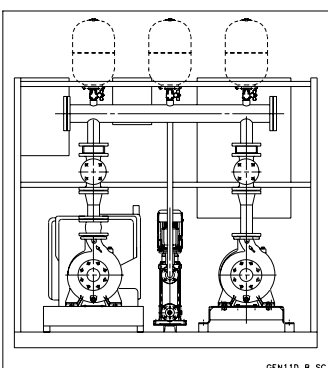

GEN110_B_SC

GEN..D/SHF RANGE

- The range of EN 12845 fire-fighting booster sets with diesel and electric service pumps and optional jockey pump to adapt to the specific needs of every application.

D.. DIESEL ENGINE PUMP

- Single fire-fighting centrifugal pump in horizontal design with stainless steel casing, SHF series.

Head up to 100 m.
Flow up to 220 m³/h.

GEN..00D SERIES

- Fire-fighting sets with diesel engine centrifugal service pump, in horizontal design with stainless steel casing, SHF series.

Head up to 100 m.
Flow up to 220 m³/h.

GEN..01D SERIES

- Fire-fighting sets with diesel engine service pump and electric jockey pump. The centrifugal service pump has horizontal design and stainless steel casing. SHF series.

Head up to 100 m.
Flow up to 220 m³/h.

GEN..10D SERIES

- Fire-fighting sets with diesel engine centrifugal service pump. The centrifugal service pump has horizontal design and stainless steel casing. SHF series.

Head up to 100 m.
Flow up to 440 m³/h.

GEN..11D SERIES

- Fire-fighting sets with diesel engine service pump, electric service pump and electric jockey pump. The centrifugal service pump has horizontal design and stainless steel casing. SHF series.

Head up to 100 m.
Flow up to 440 m³/h.

GEN..D/SHF

GEN..D/SHF BOOSTER SETS SERIES HYDRAULIC PERFORMANCE TABLE AT 50 HZ (JOCKEY PUMP)

PUMP TYPE	NOMINAL POWER		Q = DELIVERY						
			l/min 0	12	20	25	30	35	40
	kW	HP	m ³ /h 0	0,7	1,2	1,5	1,8	2,1	2,4
H = TOTAL HEAD METRES COLUMN OF WATER									
1SV 02	0,37	0,5	12,2	12,2	11,5	10,7	9,5	7,9	6,0
1SV 03	0,37	0,5	18,0	18,0	17,0	15,7	13,8	11,4	8,4
1SV 04	0,37	0,5	23,7	23,5	22,1	20,4	17,9	14,6	10,6
1SV 05	0,37	0,5	29,3	28,9	27,0	24,8	21,6	17,4	12,5
1SV 06	0,37	0,5	34,8	34,2	31,7	28,9	25,0	20,0	14,0
1SV 07	0,37	0,5	40,2	39,2	36,1	32,7	28,1	22,2	15,2
1SV 08	0,55	0,75	48,1	47,9	45,2	41,8	36,8	30,4	22,4
1SV 09	0,55	0,75	53,7	53,4	50,4	46,4	40,8	33,5	24,6
1SV 10	0,55	0,75	59,4	59,0	55,5	51,0	44,7	36,6	26,6
1SV 11	0,55	0,75	65,1	64,5	60,4	55,5	48,5	39,5	28,5
1SV 12	0,75	1	73,3	73,1	69,3	64,3	57,1	47,6	35,7
1SV 13	0,75	1	79,2	78,9	74,8	69,4	61,6	51,2	38,2
1SV 15	0,75	1	90,9	90,5	85,6	79,3	70,1	58,1	43,1
1SV 17	1,1	1,5	105,2	104,9	100,0	93,1	82,6	68,6	51,2
1SV 19	1,1	1,5	117,0	116,7	111,0	103,2	91,5	75,8	56,3
1SV 22	1,1	1,5	134,6	134,1	127,4	118,1	104,4	86,1	63,5
1SV 25	1,5	2	152,6	152,4	145,5	135,4	120,0	99,1	72,7

Prestazioni conformi alle norme ISO 9906 - Annex A.

EN12845_pp_1sv-2p50-en_a_th

GEN..D/SHF BOOSTER SETS SERIES SERVICE PUMP – JOCKEY PUMP COMBINATIONS

SERVICE PUMP		JOCKEY PUMP									
ELECTRIC PUMP	TYPE SHF	1SV 07	1SV 08	1SV 09	1SV 10	1SV 11	1SV 12	1SV 13	1SV 15	1SV 17	1SV 19
	PUMP										
32-125/07	32-125/D121	•									
32-125/11	32-125/D136		•								
32-160/15	32-160/D150		•								
32-160/22	32-160/D168			•							
32-200/30	32-200/D188					•					
32-200/40	32-200/D204						•				
32-250/55	32-250/D222						•				
32-250/75	32-250/D242								•		
32-250/110	32-250/D256									•	
40-125/11	40-125/D112	•									
40-125/15	40-125/D126	•									
40-125/22	40-125/D143		•								
40-160/30	40-160/D159			•							
40-160/40	40-160/D171				•						
40-200/55	40-200/D190					•					
40-200/75	40-200/D209						•				
40-250/110A	40-250/D218							•			
40-250/110	40-250/D233								•		
40-250/150	40-250/D251									•	
50-125/22	50-125/D119	•									
50-125/30	50-125/D130		•								
50-125/40	50-125/D139		•								
50-160/55	50-160/D158			•							
50-160/75	50-160/D174				•						
50-200/110A	50-200/D197						•				
50-200/110	50-200/D209						•				
50-250/150	50-250/D224								•		
50-250/185	50-250/D237								•		
50-250/220	50-250/D250									•	
65-160/40	65-160/D119		•								
65-160/55	65-160/D129		•								
65-160/75	65-160/D137		•								
65-160/110A	65-160/D168				•						
65-160/110	65-160/D177				•						
65-200/150	65-200/D192						•				
65-200/185	65-200/D203						•				
65-200/220	65-200/D215								•		
65-250/300	65-250/D240									•	
65-250/370	65-250/D255									•	
80-160/110	80-160/D169			•							
80-160/150	80-160/D177				•						
80-160/185	80-160/D186					•					
80-200/220	80-200/D198						•				
80-200/300	80-200/D215							•			
80-200/370	80-200/D226								•		
80-250/450	80-250/D237								•		
80-250/550	80-250/D252									•	
80-250/750	80-250/D270										•

12845-SHF_ap-en_b_tc

HYDRAULIC PERFORMANCE TABLE AT 50 HZ (POSITIVE SUCTION HEAD) GEN..D/SHF 32 BOOSTER SETS SERIES

TYPE SHF..	PUMP	RATED POWER kW	RISK CLASS												
			LHn												
			Q = DELIVERY												
ELECTRIC PUMP	PUMP	kW	l/min 0	150	180	200	225	300	350	375	400	416	425	450	540
			m ³ /h 0	9	11	12	14	18	21	23	24	25	26	27	32
H = TOTAL HEAD METRES COLUMN OF WATER															
32-125/07	32-125/D121	1 x 0,75	16,7	14,0	12,9	12,1	11,0	7,6	5,1	3,7	1,9				
32-125/11	32-125/D136	1 x 1,1	21,6	19,0	17,9	17,0	15,9	12,3	9,6	8,1	6,2				
32-160/15	32-160/D150	1 x 1,5	27,6	24,2	22,9	21,8	20,5	16,3	13,0	11,3	9,1				
32-160/22	32-160/D168	1 x 2,2	35,0	32,0	30,9	29,9	28,7	24,7	21,5	19,7	17,5	16,1	15,2	13,1	
32-200/30	32-200/D188	1 x 3	43,8	38,1	36,4	35,1	33,4	28,0	23,9	21,6	18,8	17,1			
32-200/40	32-200/D204	1 x 4	53,6	48,6	47,1	45,9	44,4	39,3	35,1	32,8	29,9	28,1	27,0	24,1	
32-250/55	32-250/D222	1 x 5,5	61,7	56,3	54,6	53,2	51,6	46,0	41,7	39,3	36,4				
32-250/75	32-250/D242	1 x 7,5	74,1	68,4	66,7	65,3	63,6	58,1	53,8	51,4	48,6	46,9	45,8		
32-250/110	32-250/D256	1 x 11	86,3	79,8	77,9	76,5	74,7	69,0	64,7	62,3	59,5	57,8	56,7	54,0	

Performance levels relative to set with 1 service pump running and compliant with ISO 9906 - Annex A.

12845_1pg-sp-shf32-2p50-en_a_th

LHn = risk class value referred to the required rated capacity (Tab.6 para 7.3.1 EN12845)

Inlet pressure drops must be deducted. Make sure that these drops, added to the difference in level (max. 3.2m), are less than 4.5m

The values shown identify performance levels according to the reference standard EN12845.

HYDRAULIC PERFORMANCE TABLE AT 50 HZ (SUCTION LIFT) GEN..D/SHF 32 BOOSTER SETS SERIES

TYPE SHF..	PUMP	RATED POWER kW	RISK CLASS												
			LHn												
			Q = DELIVERY												
ELECTRIC PUMP	PUMP	kW	l/min 0	150	180	200	225	300	350	375	400	416	425	450	540
			m ³ /h 0	9	11	12	14	18	21	23	24	25	26	27	32
H = TOTAL HEAD METRES COLUMN OF WATER															
32-125/07	32-125/D121	1 x 0,75	16,7	14,0	12,9	12,1	11,0	7,6	5,1	3,7	1,9				
32-125/11	32-125/D136	1 x 1,1	21,6	19,0	17,9	17,0	15,9	12,3	9,6	8,1	6,2				
32-160/15	32-160/D150	1 x 1,5	27,6	24,2	22,9	21,8	20,5	16,3	13,0	11,3	9,1				
32-160/22	32-160/D168	1 x 2,2	35,0	32,0	30,9	29,9	28,7	24,7	21,5	19,7	17,5	16,1	15,2	13,1	
32-200/30	32-200/D188	1 x 3	43,8	38,1	36,4	35,1	33,4	28,0	23,9	21,6	18,8	17,1			
32-200/40	32-200/D204	1 x 4	53,6	48,6	47,1	45,9	44,4	39,3	35,1	32,8	29,9	28,1	27,0	24,1	
32-250/55	32-250/D222	1 x 5,5	61,7	56,3	54,6	53,2	51,6	46,0	41,7	39,3	36,4				
32-250/75	32-250/D242	1 x 7,5	74,1	68,4	66,7	65,3	63,6	58,1	53,8	51,4	48,6	46,9	45,8		
32-250/110	32-250/D256	1 x 11	86,3	79,8	77,9	76,5	74,7	69,0	64,7	62,3	59,5	57,8	56,7	54,0	

Performance levels relative to set with 1 service pump running and compliant with ISO 9906 - Annex A.

12845_1pg-st-shf32-2p50-en_a_th

LHn = risk class value referred to the required rated capacity (Tab.6 para 7.3.1 EN12845).

Inlet pressure drops must be deducted. Make sure these drops are less than 4.5m

The values shown identify performance levels according to the reference standard EN12845.

NPSH REQUIRED FOR PUMP SERIES SHF 32

TYPE SHF..	RATED POWER	RISK CLASS	LHn													
			Q = DELIVERY													
			l/min 0	150	180	200	225	300	350	375	400	416	425	450	540	
ELECTRIC PUMP	PUMP	kW	m ³ /h 0	9	11	12	14	18	21	23	24	25	26	27	32	
			NPSHr [METRES COLUMN OF WATER]													
32-125/07	32-125/D121	1 x 0,75		1,0	1,0	1,1	1,2	1,6	2,1	2,3	2,7					
32-125/11	32-125/D136	1 x 1,1		1,0	1,0	1,1	1,2	1,6	2,1	2,3	2,7					
32-160/15	32-160/D150	1 x 1,5		1,5	1,6	1,7	1,9	2,5	3,0	3,2	3,5					
32-160/22	32-160/D168	1 x 2,2		1,2	1,4	1,5	1,6	2,2	2,8	3,3	3,8	4,2	4,4	5,2		
32-200/30	32-200/D188	1 x 3		1,7	1,8	1,9	2,1	2,8	3,7	4,3	5,2	5,8				
32-200/40	32-200/D204	1 x 4		1,6	1,8	2,0	2,2	2,8	3,4	3,9	4,6	5,1	5,5	6,9		
32-250/55	32-250/D222	1 x 5,5		2,8	3,2	3,5	3,8	5,1	6,2	6,9	7,7					
32-250/75	32-250/D242	1 x 7,5		2,7	3,0	3,2	3,5	4,5	5,3	5,8	6,3	6,6	6,9			
32-250/110	32-250/D256	1 x 11		2,7	3,0	3,2	3,5	4,5	5,3	5,8	6,3	6,6	6,9	7,5		

The declared NPSH values were obtained in the laboratory and refer to a single service pump

12845_1p-shf32-2p50_NPSHr-en_a_th

LHn = risk class value referred to the required rated capacity (Tab.6 para 7.3.1 EN12845)

Check that $NPSH_d \geq NPSH_r + 1m$ is satisfied

HYDRAULIC PERFORMANCE TABLE AT 50 HZ (POSITIVE SUCTION HEAD) GEN..D/SHF 40 BOOSTER SETS SERIES

TYPE SHF..	RATED POWER	OH1n	RISK CLASS												
			Q = DELIVERY												
			l/min 0	300	375	540	640	677	700	725	750	800	833	850	1000
ELECTRIC PUMP	PUMP	kW	m3/h 0	18	23	32	38	41	42	44	45	48	50	51	60
H = TOTAL HEAD METRES COLUMN OF WATER															
40-125/11	40-125/D112	1 x 1,1	13,9	11,3	10,0	9,3	3,4	0,7							
40-125/15	40-125/D126	1 x 1,5	18,0	15,3	14,0	13,3	7,4	4,7							
40-125/22	40-125/D143	1 x 2,2	25,3	21,8	20,5	19,8	14,0	11,4	6,4	5,0	3,6	0,6			
40-160/30	40-160/D159	1 x 3	31,6	28,1	26,8	26,0	19,5	16,5	10,8	9,2	7,6				
40-160/40	40-160/D171	1 x 4	38,3	35,1	33,7	32,9	26,5	23,6	18,1	16,5	15,0	11,7			
40-200/55	40-200/D190	1 x 5,5	46,4	42,7	41,2	40,4	33,1	29,7	23,3	21,5	19,6				
40-200/75	40-200/D209	1 x 7,5	57,5	53,1	51,6	50,7	43,8	40,7	34,8	33,2	31,5	28,0			
40-250/110A	40-250/D218	1 x 11	63,6	57,8	56,2	55,2	47,8	44,5	38,2	36,5	34,8	31,1			
40-250/110	40-250/D233	1 x 11	71,7	66,0	64,3	63,4	55,7	52,3	45,8	44,0	42,1	38,3			
40-250/150	40-250/D251	1 x 15	85,0	78,6	76,9	76,0	68,4	65,0	58,6	56,8	55,0	51,1	42,6		

Performance levels relative to set with 1 service pump running and compliant with ISO 9906 - Annex A.

12845_1pg-sp-shf40-2p50-en_a_th

OHn = risk class value referred to the required rated capacity (Tab.6 para 7.3.1 EN12845)

Inlet pressure drops must be deducted. Make sure that these drops, added to the difference in level (max. 3.2m), are less than 4.5m

The values shown identify performance levels according to the reference standard EN12845.

HYDRAULIC PERFORMANCE TABLE AT 50 HZ (SUCTION LIFT) GEN..D/SHF 40 BOOSTER SETS SERIES

TYPE SHF..	RATED POWER	OH1n	RISK CLASS												
			Q = DELIVERY												
			l/min 0	300	375	540	640	677	700	725	750	800	833	850	1000
ELECTRIC PUMP	PUMP	kW	m3/h 0	18	23	32	38	41	42	44	45	48	50	51	60
H = TOTAL HEAD METRES COLUMN OF WATER															
40-125/11	40-125/D112	1 x 1,1	13,9	11,3	10,0	9,3	3,4	0,7							
40-125/15	40-125/D126	1 x 1,5	18,0	15,3	14,0	13,3	7,4	4,7							
40-125/22	40-125/D143	1 x 2,2	25,3	21,8	20,5	19,8	14,0	11,4	6,4	5,0	3,6	0,6			
40-160/30	40-160/D159	1 x 3	31,6	28,1	26,8	26,0	19,5	16,5	10,8	9,2	7,6				
40-160/40	40-160/D171	1 x 4	38,3	35,1	33,7	32,9	26,5	23,6	18,1	16,5	15,0	11,7			
40-200/55	40-200/D190	1 x 5,5	46,4	42,7	41,2	40,4	33,1	29,7	23,3	21,5	19,6				
40-200/75	40-200/D209	1 x 7,5	57,5	53,1	51,6	50,7	43,8	40,7	34,8	33,2	31,5	28,0			
40-250/110A	40-250/D218	1 x 11	63,6	57,8	56,2	55,2	47,8	44,5	38,2	36,5	34,8	31,1			
40-250/110	40-250/D233	1 x 11	71,7	66,0	64,3	63,4	55,7	52,3	45,8	44,0	42,1	38,3			
40-250/150	40-250/D251	1 x 15	85,0	78,6	76,9	76,0	68,4	65,0	58,6	56,8	55,0	51,1	42,6		

Performance levels relative to set with 1 service pump running and compliant with ISO 9906 - Annex A.

12845_1pg-st-shf40-2p50-en_a_th

OHn = risk class value referred to the required rated capacity (Tab.6 para 7.3.1 EN12845)

Inlet pressure drops must be deducted. Make sure these drops are less than 4.5m

The values shown identify performance levels according to the reference standard EN12845.

NPSH REQUIRED FOR PUMP SERIES SHF 40

TYPE SHF..	RATED POWER	RISK CLASS																
		ELECTRIC PUMP	PUMP	kW	OH1n		OH1m		Q = DELIVERY									
					l/min 0	300	375	540	640	677	700	725	750	800	833	850	1000	
					m ³ /h 0	18	23	32	38	41	42	44	45	48	50	51	60	
NPSHr [METRES COLUMN OF WATER]																		
40-125/11	40-125/D112	1 x 1,1		0,7	1,0	1,5	2,0											
40-125/15	40-125/D126	1 x 1,5		0,7	1,0	1,5	2,0	2,3	2,5									
40-125/22	40-125/D143	1 x 2,2		0,7	1,0	1,5	2,0	2,3	2,5	2,8	3,1							
40-160/30	40-160/D159	1 x 3		1,1	1,4	2,1	2,6	2,9	3,2	3,5	3,8							
40-160/40	40-160/D171	1 x 4		1,1	1,4	2,1	2,6	2,9	3,2	3,5	3,8	4,9						
40-200/55	40-200/D190	1 x 5,5		1,4	1,8	2,7	3,4	3,7	3,9	4,2	4,5	5,4						
40-200/75	40-200/D209	1 x 7,5		1,4	1,8	2,7	3,4	3,7	3,9	4,2	4,5	5,4	6,4					
40-250/110A	40-250/D218	1 x 11		1,4	1,4	1,7	3,0	4,1	5,0									
40-250/110	40-250/D233	1 x 11		1,3	1,4	1,6	1,8	1,9										
40-250/150	40-250/D251	1 x 15		1,3	1,4	1,6	1,8	1,9	2,1	2,2	2,5	3,3	4,3	5,0				

The declared NPSH values were obtained in the laboratory and refer to a single service pump

12845_1p-shf40-2p50_NPSHr-en_a_th

OHn, OHm = risk class value referred to the required rated and maximum capacity (Tab.6 para 7.3.1 EN12845)

Check that $NPSH_d \geq NPSH_r + 1m$ is satisfied at the maximum requested capacity

HYDRAULIC PERFORMANCE TABLE AT 50 HZ (POSITIVE SUCTION HEAD) GEN..D/SHF 50 BOOSTER SETS SERIES

TYPE SHF..	RATED POWER	RISK CLASS OH2n OH3n	RISK CLASS												
			Q = DELIVERY												
			l/min 0	600	680	725	1000	1100	1200	1300	1350	1380	1400	1450	1500
ELECTRIC PUMP	PUMP	kW	m3/h 0	36	41	44	60	66	72	78	81	83	84	87	90
H = TOTAL HEAD METRES COLUMN OF WATER															
50-125/22	50-125/D119	1 x 2,2	17,2	13,2	12,0	11,3	5,9	3,6	1,2						
50-125/30	50-125/D130	1 x 3	21,7	17,4	16,1	15,3	9,8	7,6	5,2	2,8					
50-125/40	50-125/D139	1 x 4	25,6	21,8	20,6	19,8	14,4	12,1	9,8	7,3	6,0	5,3	4,7		
50-160/55	50-160/D158	1 x 5,5	34,0	29,3	27,8	26,9	20,4	17,5	14,4	11,1	9,4	8,3	7,6		
50-160/75	50-160/D174	1 x 7,5	40,7	36,1	34,7	33,9	27,6	24,7	21,6	18,1	16,3	15,2	14,4	12,5	10,4
50-200/110A	50-200/D197	1 x 11	34,0	29,3	27,8	26,9	20,4	17,5	14,4	11,1	9,4	8,3	7,6		
50-200/110	50-200/D209	1 x 11	40,7	36,1	34,7	33,9	27,6	24,7	21,6	18,1	16,3	15,2	14,4	12,5	
50-250/150	50-250/D224	1 x 15	70,3	65,5	64,0	63,0	54,6	50,4	45,4	39,6					
50-250/185	50-250/D237	1 x 18,5	80,1	73,8	72,1	71,1	62,8	58,7	54,1	48,9	46,0	44,2			
50-250/220	50-250/D250	1 x 22	88,9	83,2	81,6	80,6	72,3	68,4	64,0	59,1	56,4	54,7	53,6	50,6	

Performance levels relative to set with 1 service pump running and compliant with ISO 9906 - Annex A.

12845_1pg-sp-shf50-2p50-en_a_th

OHn = risk class value referred to the required rated capacity (Tab.6 para 7.3.1 EN12845)

Inlet pressure drops must be deducted. Make sure that these drops, added to the difference in level (max. 3.2m), are less than 4.5m

The values shown identify performance levels according to the reference standard EN12845.

HYDRAULIC PERFORMANCE TABLE AT 50 HZ (SUCTION LIFT) GEN..D/SHF 50 BOOSTER SETS SERIES

TYPE SHF..	RATED POWER	RISK CLASS OH2n OH3n	RISK CLASS												
			Q = DELIVERY												
			l/min 0	600	680	725	1000	1100	1200	1300	1350	1380	1400	1450	1500
ELECTRIC PUMP	PUMP	kW	m3/h 0	36	41	44	60	66	72	78	81	83	84	87	90
H = TOTAL HEAD METRES COLUMN OF WATER															
50-125/22	50-125/D119	1 x 2,2	17,2	13,2	12,0	11,3	5,9	3,6	1,2						
50-125/30	50-125/D130	1 x 3	21,7	17,4	16,1	15,3	9,8	7,6	5,2	2,8					
50-125/40	50-125/D139	1 x 4	25,6	21,8	20,6	19,8	14,4	12,1	9,8	7,3	6,0	5,3	4,7		
50-160/55	50-160/D158	1 x 5,5	34,0	29,3	27,8	26,9	20,4	17,5	14,4	11,1	9,4	8,3	7,6		
50-160/75	50-160/D174	1 x 7,5	40,7	36,1	34,7	33,9	27,6	24,7	21,6	18,1	16,3	15,2	14,4	12,5	10,4
50-200/110A	50-200/D197	1 x 11	34,0	29,3	27,8	26,9	20,4	17,5	14,4	11,1	9,4	8,3	7,6		
50-200/110	50-200/D209	1 x 11	40,7	36,1	34,7	33,9	27,6	24,7	21,6	18,1	16,3	15,2	14,4	12,5	
50-250/150	50-250/D224	1 x 15	70,3	65,5	64,0	63,0	54,6	50,4	45,4	39,6					
50-250/185	50-250/D237	1 x 18,5	80,1	73,8	72,1	71,1	62,8	58,7	54,1	48,9	46,0	44,2			
50-250/220	50-250/D250	1 x 22	88,9	83,2	81,6	80,6	72,3	68,4	64,0	59,1	56,4	54,7	53,6	50,6	

Performance levels relative to set with 1 service pump running and compliant with ISO 9906 - Annex A.

12845_1pg-st-shf50-2p50-en_a_th

OHn = risk class value referred to the required rated capacity (Tab.6 para 7.3.1 EN12845)

Inlet pressure drops must be deducted. Make sure these drops are less than 4.5m

The values shown identify performance levels according to the reference standard EN12845.

NPSH REQUIRED FOR PUMP SERIES SHF 50

TYPE SHF..	RATED POWER	RISK CLASS															
				OH2n		OH2m		OH3n		OH3m							
		Q = DELIVERY															
		l/min 0	600	680	725	1000	1100	1200	1300	1350	1380	1400	1450	1500			
ELECTRIC PUMP	PUMP	kW		NPSHr [METRES COLUMN OF WATER]													
				m ³ /h 0	36	41	44	60	66	72	78	81	83	84	87	90	
50-125/22	50-125/D119	1 x 2,2		1,6	1,8	1,9	2,8	3,4	4,3								
50-125/30	50-125/D130	1 x 3		1,6	1,8	1,9	2,7	3,1	3,7	4,6							
50-125/40	50-125/D139	1 x 4		1,6	1,8	1,9	2,7	3,1	3,7	4,6	5,2	5,7	6,0				
50-160/55	50-160/D158	1 x 5,5		2,0	2,1	2,1	2,8	3,2	3,7	4,7	5,4	5,9	6,3				
50-160/75	50-160/D174	1 x 7,5		1,9	2,1	2,2	2,8	3,1	3,6	4,3	4,9	5,3	5,6	6,5	7,6		
50-200/110A	50-200/D197	1 x 11		2,0	2,1	2,1	2,8	3,2	4,0	5,2	6,1	6,7	7,2				
50-200/110	50-200/D209	1 x 11		1,9	2,1	2,2	2,8	3,2	3,7	4,7	5,4	5,9	6,3	7,5			
50-250/150	50-250/D224	1 x 15		1,6	1,7	1,8	2,3	2,7	3,3	4,8							
50-250/185	50-250/D237	1 x 18,5		1,5	1,7	1,8	2,4	2,7	3,1	3,7	4,1	4,4					
50-250/220	50-250/D250	1 x 22		1,5	1,7	1,8	2,4	2,7	3,1	3,7	4,1	4,4	4,7	5,4			

The declared NPSH values were obtained in the laboratory and refer to a single service pump

12845_1p-shf50-2p50_NPSHr-en_a_th

OHn, OHm = risk class value referred to the required rated and maximum capacity (Tab.6 para 7.3.1 EN12845)

Check that $NPSH_d \geq NPSH_r + 1m$ is satisfied at the maximum requested capacity

HYDRAULIC PERFORMANCE TABLE AT 50 HZ (POSITIVE SUCTION HEAD) GEN..D/SHF 65 BOOSTER SETS SERIES

TYPE SHF..	RATED POWER	RISK CLASS													
		OH3n							OH4n						
		Q = DELIVERY													
ELECTRIC PUMP	PUMP	kW	l/min 0	800	900	1000	1100	1350	1500	1800	1900	2000	2050	2100	2200
			m3/h 0	48	54	60	66	81	90	108	114	120	123	126	132
H = TOTAL HEAD METRES COLUMN OF WATER															
65-160/40	65-160/D119	1 x 4	19,6	15,9	14,9	13,8	12,6	9,4	7,3	2,9					
65-160/55	65-160/D129	1 x 5,5	24,2	20,5	19,5	18,4	17,2	13,9	11,7	7,0	5,4				
65-160/75	65-160/D137	1 x 7,5	28,2	25,1	24,2	23,1	22,0	18,8	16,7	12,0	10,4	8,7			
65-160/110A	65-160/D168	1 x 11	38,2	34,3	33,0	31,5	29,8	25,2	22,0	15,2	12,9				
65-160/110	65-160/D177	1 x 11	42,9	39,7	38,4	36,9	35,3	30,6	27,4	20,5	18,1	15,6			
65-200/150	65-200/D192	1 x 15	53,0		47,5	45,9	44,1	38,9	35,3	27,1	24,1				
65-200/185	65-200/D203	1 x 18,5	60,2		55,2	53,6	51,9	46,9	43,4	35,5	32,6	29,5			
65-200/220	65-200/D215	1 x 22	68,0		63,0	61,6	60,0	55,2	51,9	44,3	41,5	38,5	37,0	35,5	
65-250/300	65-250/D240	1 x 30	83,7			80,2	78,9	74,9	71,9	64,4	61,4	58,3	56,6	54,9	
65-250/370	65-250/D255	1 x 37	96,7			93,6	92,2	88,0	84,9	77,4	74,6	71,7	70,1	68,5	65,2

Performance levels relative to set with 1 service pump running and compliant with ISO 9906 - Annex A.

12845_1pg-sp-shf65-2p50-en_a_th

OHn = risk class value referred to the required rated capacity (Tab.6 para 7.3.1 EN12845)

Inlet pressure drops must be deducted. Make sure that these drops, added to the difference in level (max. 3.2m), are less than 4.5m

The values shown identify performance levels according to the reference standard EN12845.

HYDRAULIC PERFORMANCE TABLE AT 50 HZ (SUCTION LIFT) GEN..D/SHF 65 BOOSTER SETS SERIES

TYPE SHF..	RATED POWER	RISK CLASS													
		OH3n							OH4n						
		Q = DELIVERY													
ELECTRIC PUMP	PUMP	kW	l/min 0	800	900	1000	1100	1350	1500	1800	1900	2000	2050	2100	2200
			m3/h 0	48	54	60	66	81	90	108	114	120	123	126	132
H = TOTAL HEAD METRES COLUMN OF WATER															
65-160/40	65-160/D119	1 x 4	19,6	15,9	14,9	13,8	12,6	9,4	7,3	2,9					
65-160/55	65-160/D129	1 x 5,5	24,2	20,5	19,5	18,4	17,2	13,9	11,7	7,0	5,4				
65-160/75	65-160/D137	1 x 7,5	28,2	25,1	24,2	23,1	22,0	18,8	16,7	12,0	10,4	8,7			
65-160/110A	65-160/D168	1 x 11	38,2	34,3	33,0	31,5	29,8	25,2	22,0	15,2	12,9				
65-160/110	65-160/D177	1 x 11	42,9	39,7	38,4	36,9	35,3	30,6	27,4	20,5	18,1	15,6			
65-200/150	65-200/D192	1 x 15	53,0		47,5	45,9	44,1	38,9	35,3	27,1	24,1				
65-200/185	65-200/D203	1 x 18,5	60,2		55,2	53,6	51,9	46,9	43,4	35,5	32,6	29,5			
65-200/220	65-200/D215	1 x 22	68,0		63,0	61,6	60,0	55,2	51,9	44,3	41,5	38,5	37,0	35,5	
65-250/300	65-250/D240	1 x 30	83,7			80,2	78,9	74,9	71,9	64,4	61,4	58,3	56,6	54,9	
65-250/370	65-250/D255	1 x 37	96,7			93,6	92,2	88,0	84,9	77,4	74,6	71,7	70,1	68,5	65,2

Performance levels relative to set with 1 service pump running and compliant with ISO 9906 - Annex A.

12845_1pg-st-shf65-2p50-en_a_th

OHn = risk class value referred to the required rated capacity (Tab.6 para 7.3.1 EN12845)

Inlet pressure drops must be deducted. Make sure these drops are less than 4.5m

The values shown identify performance levels according to the reference standard EN12845.

NPSH REQUIRED FOR PUMP SERIES SHF 65

TYPE SHF..	RATED POWER	RISK CLASS															
				OH3n		OH3m		OH4n		OH4m							
		Q = DELIVERY															
		l/min 0	800	900	1000	1100	1350	1400	1500	1800	1900	2000	2100	2200			
ELECTRIC PUMP	PUMP	kW	m ³ /h 0	48	54	60	66	81	84	90	108	114	120	126	132		
NPSHr [METRES COLUMN OF WATER]																	
65-160/40	65-160/D119	1 x 4		1,9	1,8	1,9	1,9	2,5	2,7	3,3	7,4						
65-160/55	65-160/D129	1 x 5,5		1,9	1,9	1,9	1,9	2,4	2,6	3,1	5,4	6,6					
65-160/75	65-160/D137	1 x 7,5		1,9	1,9	1,9	1,9	2,4	2,6	3,1	5,4	6,6	8,0				
65-160/110A	65-160/D168	1 x 11		1,3	1,4	1,6	1,7	2,1	2,1	2,4	3,5	4,2					
65-160/110	65-160/D177	1 x 11		1,3	1,4	1,6	1,7	2,1	2,1	2,4	3,5	4,2	5,2				
65-200/150	65-200/D192	1 x 15			1,7	1,7	1,6	1,7	1,7	1,9	4,1	6,4					
65-200/185	65-200/D203	1 x 18,5			1,7	1,7	1,6	1,7	1,7	1,9	3,0	3,9	5,3				
65-200/220	65-200/D215	1 x 22			1,7	1,7	1,6	1,7	1,7	1,9	3,0	3,9	5,3	7,5			
65-250/300	65-250/D240	1 x 30				1,3	1,3	1,4	1,5	1,7	3,2	4,1	5,4	7,0			
65-250/370	65-250/D255	1 x 37				1,3	1,3	1,3	1,4	1,6	2,9	3,7	4,8	6,2	8,1		

The declared NPSH values were obtained in the laboratory and refer to a single service pump

12845_1p-shf65-2p50_NPSHr-en_a_th

OHn, OHm = risk class value referred to the required rated and maximum capacity (Tab.6 para 7.3.1 EN12845)

Check that $NPSHd \geq NPSHr + 1m$ is satisfied at the maximum requested capacity

HYDRAULIC PERFORMANCE TABLE AT 50 HZ (POSITIVE SUCTION HEAD) GEN..D/SHF 80 BOOSTER SETS SERIES

TYPE SHF..	RATED POWER	RISK CLASS OH4n HH1n	Q = DELIVERY												
			H = TOTAL HEAD METRES COLUMN OF WATER												
			l/min 0	1200	1500	1800	2100	2300	3216	3300	3500	3600	3700	3800	4000
ELECTRIC PUMP	PUMP	kW	m ³ /h 0	72	90	108	126	138	193	198	210	216	222	228	240
80-160/110	80-160/D169	1 x 11	33,0	30,9	28,6	25,7	22,2	19,7	6,2	4,8					
80-160/150	80-160/D177	1 x 15	39,5	37,8	35,6	32,7	29,4	26,9	13,2	11,8	8,4				
80-160/185	80-160/D186	1 x 18,5	46,4	44,7	42,6	39,8	36,6	34,2	20,7	19,3	15,9	14,1	12,4		
80-200/220	80-200/D198	1 x 22	51,9		48,5	45,8	42,5	40,1	26,7	25,3	21,9	20,2			
80-200/300	80-200/D215	1 x 30	62,2		59,7	57,1	53,9	51,5	37,8	36,4	32,9	31,1	29,3	27,4	
80-200/370	80-200/D226	1 x 37	69,8	69,9	68,1	65,7	62,8	60,5	47,2	45,7	42,2	40,4	38,5	36,6	32,7
80-250/450	80-250/D237	1 x 45	82,2		79,1	76,2	72,6	69,8	53,3	51,5	47,0	44,6			
80-250/550	80-250/D252	1 x 55	93,9		91,9	89,2	85,9	83,2	67,7	66,0	61,8	59,6	57,3		
80-250/750	80-250/D270	1 x 75	109,7		108,6	106,0	102,7	100,2	85,0	83,3	79,2	77,0	74,8	72,5	

Performance levels relative to set with 1 service pump running and compliant with ISO 9906 - Annex A.

12845_1pg-sp-shf80-2p50-en_a_th

OHn = risk class value referred to the required rated capacity (Tab.6 para 7.3.1 EN12845)

Inlet pressure drops must be deducted. Make sure that these drops, added to the difference in level (max. 3.2m), are less than 4.5m

The values shown identify performance levels according to the reference standard EN12845.

HYDRAULIC PERFORMANCE TABLE AT 50 HZ (SUCTION LIFT) GEN..D/SHF 80 BOOSTER SETS SERIES

TYPE SHF..	RATED POWER	RISK CLASS OH4n HH1n	Q = DELIVERY												
			H = TOTAL HEAD METRES COLUMN OF WATER												
			l/min 0	1200	1500	1800	2100	2300	3216	3300	3500	3600	3700	3800	4000
ELECTRIC PUMP	PUMP	kW	m ³ /h 0	72	90	108	126	138	193	198	210	216	222	228	240
80-160/110	80-160/D169	1 x 11	33,0	30,9	28,6	25,7	22,2	19,7	6,2	4,8					
80-160/150	80-160/D177	1 x 15	39,5	37,8	35,6	32,7	29,4	26,9	13,2	11,8	8,4				
80-160/185	80-160/D186	1 x 18,5	46,4	44,7	42,6	39,8	36,6	34,2	20,7	19,3	15,9	14,1	12,4		
80-200/220	80-200/D198	1 x 22	51,9		48,5	45,8	42,5	40,1	26,7	25,3	21,9	20,2			
80-200/300	80-200/D215	1 x 30	62,2		59,7	57,1	53,9	51,5	37,8	36,4	32,9	31,1	29,3	27,4	
80-200/370	80-200/D226	1 x 37	69,8	69,9	68,1	65,7	62,8	60,5	47,2	45,7	42,2	40,4	38,5	36,6	32,7
80-250/450	80-250/D237	1 x 45	82,2		79,1	76,2	72,6	69,8	53,3	51,5	47,0	44,6			
80-250/550	80-250/D252	1 x 55	93,9		91,9	89,2	85,9	83,2	67,7	66,0	61,8	59,6	57,3		
80-250/750	80-250/D270	1 x 75	109,7		108,6	106,0	102,7	100,2	85,0	83,3	79,2	77,0	74,8	72,5	

Performance levels relative to set with 1 service pump running and compliant with ISO 9906 - Annex A.

12845_1pg-st-shf80-2p50-en_a_th

OHn = risk class value referred to the required rated capacity (Tab.6 para 7.3.1 EN12845)

Inlet pressure drops must be deducted. Make sure these drops are less than 4.5m

The values shown identify performance levels according to the reference standard EN12845.

NPSH REQUIRED FOR PUMP SERIES SHF 80

TYPE SHF..	RATED POWER	RISK CLASS															
		Q = DELIVERY															
		OH4n	OH4m	HH1n	HH1m	1200	1500	1800	2100	2300	3216	3300	3500	3600	3700	3800	4000
ELECTRIC PUMP	PUMP	kW	l/min 0	1200	1500	1800	2100	2300	3216	3300	3500	3600	3700	3800	4000		
			m ³ /h 0	72	90	108	126	138	193	198	210	216	222	228	240		
			NPSHr [METRES COLUMN OF WATER]														
80-160/110	80-160/D169	1 x 11		2,3	2,5	2,7	3,0	3,2	5,9	6,5							
80-160/150	80-160/D177	1 x 15		2,3	2,5	2,7	2,9	3,0	4,3	4,6	5,5						
80-160/185	80-160/D186	1 x 18,5		2,3	2,5	2,7	2,9	3,0	4,3	4,6	5,5	6,1	6,8				
80-200/220	80-200/D198	1 x 22			2,2	2,4	2,7	2,8	3,9	4,1	4,6	4,9					
80-200/300	80-200/D215	1 x 30			2,2	2,4	2,6	2,8	3,7	3,8	4,2	4,4	4,7	5,0			
80-200/370	80-200/D226	1 x 37		2,0	2,2	2,4	2,6	2,8	3,7	3,8	4,2	4,4	4,7	5,0	6,0		
80-250/450	80-250/D237	1 x 45			1,9	2,2	2,4	2,6	3,6	3,7	4,2	4,6					
80-250/550	80-250/D252	1 x 55			1,9	2,2	2,4	2,6	3,6	3,7	4,2	4,6	5,1				
80-250/750	80-250/D270	1 x 75			1,9	2,2	2,4	2,6	3,6	3,7	4,2	4,6	5,1	6,0			

The declared NPSH values were obtained in the laboratory and refer to a single service pump

12845_1p-shf80-2p50_NPSHr-en_a_th

OHn, OHm, HHn, HHm = risk class value referred to the required rated and maximum capacity (Tab.6 para 7.3.1, Tab.7 para 7.3.2 EN12845)

Check that $NPSHd \geq NPSHr + 1m$ is satisfied at the maximum requested capacity

GEN..D/SHF 32-80 BOOSTER SETS ELECTRICAL DATA TABLE AT 50 Hz

SERVICE PUMP 3 X 400 V				ELECTRIC JOCKEY PUMP				CURRENT (*) ABSORBED SET			
TYPE SHF..		NOMINAL POWER		TYPE	Pn kW	1x230V	3x400V	1 x 230V		3x400	
ELECTRIC PUMP	PUMP	Pn kW	In A			In A	In A	GEN..00D A	GEN..01D A	GEN..10D A	GEN..11D A
32-125/07	32-125/D121	0,75	1,76	1SV 07	0,37	2,82	1,35	3	5,82	4,76	6,11
32-125/11	32-125/D136	1,1	2,36	1SV 08	0,55	3,88	1,48	3	6,88	5,36	6,84
32-160/15	32-160/D150	1,5	3,02	1SV 08	0,55	3,88	1,48	3	6,88	6,02	7,5
32-160/22	32-160/D168	2,2	4,64	1SV 09	0,55	3,88	1,48	3	6,88	7,64	9,1
32-200/30	32-200/D188	3	5,91	1SV 11	0,55	3,88	1,48	3	6,88	8,91	10,4
32-200/40	32-200/D204	4	7,5	1SV 12	0,75	4,88	1,76	3	7,88	10,5	12,3
32-250/55	32-250/D222	5,5	11	1SV 12	0,75	4,88	1,76	3	7,88	14	15,8
32-250/75	32-250/D242	7,5	14,3	1SV 15	0,75	4,88	1,76	3	7,88	17,3	19,1
32-250/110	32-250/D256	11	19,8	1SV 17	1,1	6,77	2,36	3	9,77	22,8	25,2
40-125/11	40-125/D112	1,1	2,36	1SV 07	0,37	2,82	1,35	3	5,82	5,36	6,71
40-125/15	40-125/D126	1,5	3,02	1SV 07	0,37	2,82	1,35	3	5,82	6,02	7,37
40-125/22	40-125/D143	2,2	4,64	1SV 08	0,55	3,88	1,48	3	6,88	7,64	9,1
40-160/30	40-160/D159	3	5,91	1SV 09	0,55	3,88	1,48	3	6,88	8,91	10,4
40-160/40	40-160/D171	4	7,5	1SV 10	0,55	3,88	1,48	3	6,88	10,5	12,0
40-200/55	40-200/D190	5,5	11	1SV 11	0,55	3,88	1,48	3	6,88	14	15,5
40-200/75	40-200/D209	7,5	14,3	1SV 12	0,75	4,88	1,76	3	7,88	17,3	19,1
40-250/110A	40-250/D218	11	19,8	1SV 13	0,75	4,88	1,76	3	7,88	22,8	24,6
40-250/110	40-250/D233	11	19,8	1SV 15	0,75	4,88	1,76	3	7,88	22,8	24,6
40-250/150	40-250/D251	15	26,2	1SV 17	1,1	6,77	2,36	3	9,77	29,2	31,6
50-125/22	50-125/D119	2,2	4,64	1SV 07	0,37	2,82	1,35	3	5,82	7,64	9,0
50-125/30	50-125/D130	3	5,91	1SV 08	0,55	3,88	1,48	3	6,88	8,91	10,4
50-125/40	50-125/D139	4	7,5	1SV 08	0,55	3,88	1,48	3	6,88	10,5	12,0
50-160/55	50-160/D158	5,5	11	1SV 09	0,55	3,88	1,48	3	6,88	14	15,5
50-160/75	50-160/D174	7,5	14,3	1SV 10	0,55	3,88	1,48	3	6,88	17,3	18,8
50-200/110A	50-200/D197	11	19,8	1SV 12	0,75	4,88	1,76	3	7,88	22,8	24,6
50-200/110	50-200/D209	11	19,8	1SV 12	0,75	4,88	1,76	3	7,88	22,8	24,6
50-250/150	50-250/D224	15	26,2	1SV 15	0,75	4,88	1,76	3	7,88	29,2	31,0
50-250/185	50-250/D237	18,5	32,9	1SV 15	0,75	4,88	1,76	3	7,88	35,9	37,7
50-250/220	50-250/D250	22	39,1	1SV 17	1,1	6,77	2,36	3	9,77	42,1	44,5
65-160/40	65-160/D119	4	7,5	1SV 08	0,55	3,88	1,48	3	6,88	10,5	12,0
65-160/55	65-160/D129	5,5	11	1SV 08	0,55	3,88	1,48	3	6,88	14	15,5
65-160/75	65-160/D137	7,5	14,3	1SV 08	0,55	3,88	1,48	3	6,88	17,3	18,8
65-160/110A	65-160/D168	11	19,8	1SV 10	0,55	3,88	1,48	3	6,88	22,8	24,3
65-160/110	65-160/D177	11	19,8	1SV 10	0,55	3,88	1,48	3	6,88	22,8	24,3
65-200/150	65-200/D192	15	26,2	1SV 12	0,75	4,88	1,76	3	7,88	29,2	31,0
65-200/185	65-200/D203	18,5	32,9	1SV 12	0,75	4,88	1,76	3	7,88	35,9	37,7
65-200/220	65-200/D215	22	39,1	1SV 15	0,75	4,88	1,76	3	7,88	42,1	43,9
65-250/300	65-250/D240	30	53,6	1SV 17	1,1	6,77	2,36	3	9,77	56,6	59,0
65-250/370	65-250/D255	37	65,8	1SV 17	1,1	6,77	2,36	3	9,77	68,8	71,2
80-160/110	80-160/D169	11	19,8	1SV 09	0,55	3,88	1,48	3	6,88	22,8	24,3
80-160/150	80-160/D177	15	26,7	1SV 10	0,55	3,88	1,48	3	6,88	29,7	31,2
80-160/185	80-160/D186	18,5	32,9	1SV 11	0,55	3,88	1,48	3	6,88	35,9	37,4
80-200/220	80-200/D198	22	39,1	1SV 12	0,75	4,88	1,76	3	7,88	42,1	43,9
80-200/300	80-200/D215	30	53,6	1SV 13	0,75	4,88	1,76	3	7,88	56,6	58,4
80-200/370	80-200/D226	37	65,8	1SV 15	0,75	4,88	1,76	3	7,88	68,8	70,6
80-250/450	80-250/D237	45	78	1SV 15	0,75	4,88	1,76	3	7,88	81	82,8
80-250/550	80-250/D252	55	95	1SV 17	1,1	6,77	2,36	3	9,77	98	100,4
80-250/750	80-250/D270	75	129	1SV 19	1,1	6,77	2,36	3	9,77	132	134,4

ENMTP-SHF_2p50-en_d_te

(*) The current indicated is the maximum current absorbed.

At the set 3x400V three-phase power supply GEN..10D and GEN..11D to add the control panel current of the engine pump (GEN..0D) 1x230V
The sets GEN..01D have the electric jockey pump 1x230V single-phase power supply.

**Fire-fighting
booster sets
EN 12845**

MARKET SECTORS

CIVIL, INDUSTRIAL

APPLICATIONS

- Fixed fire-fighting systems.
Automatic Sprinkler systems.

**DSHF
Series**

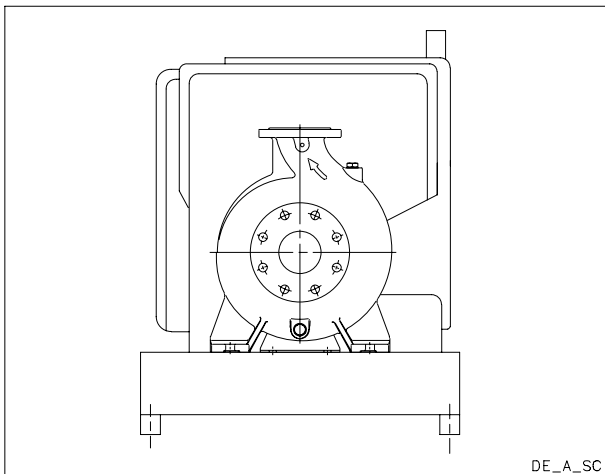

SPECIFICATIONS

- **Flow** up to 220 m³/h.
- **Head** up to 100 m.
- Panel supply power voltage:
1 x 230V ± 10%.
- Frequency: 50 Hz.
- Voltage for controls outside panel:
12 - 24 Vac.
- Protection grade:
- electric panel: IP54.
- Electric pumps maximum power
75 kW.
- Diesel engine with battery start.
- **Diesel engine service pump
in horizontal design:**
- SHF series.
- Maximum running pressure: 12 bar.

**DSHF 32-80 DIESEL ENGINE PUMP SERIES
FIRE-FIGHTING EN 12845**

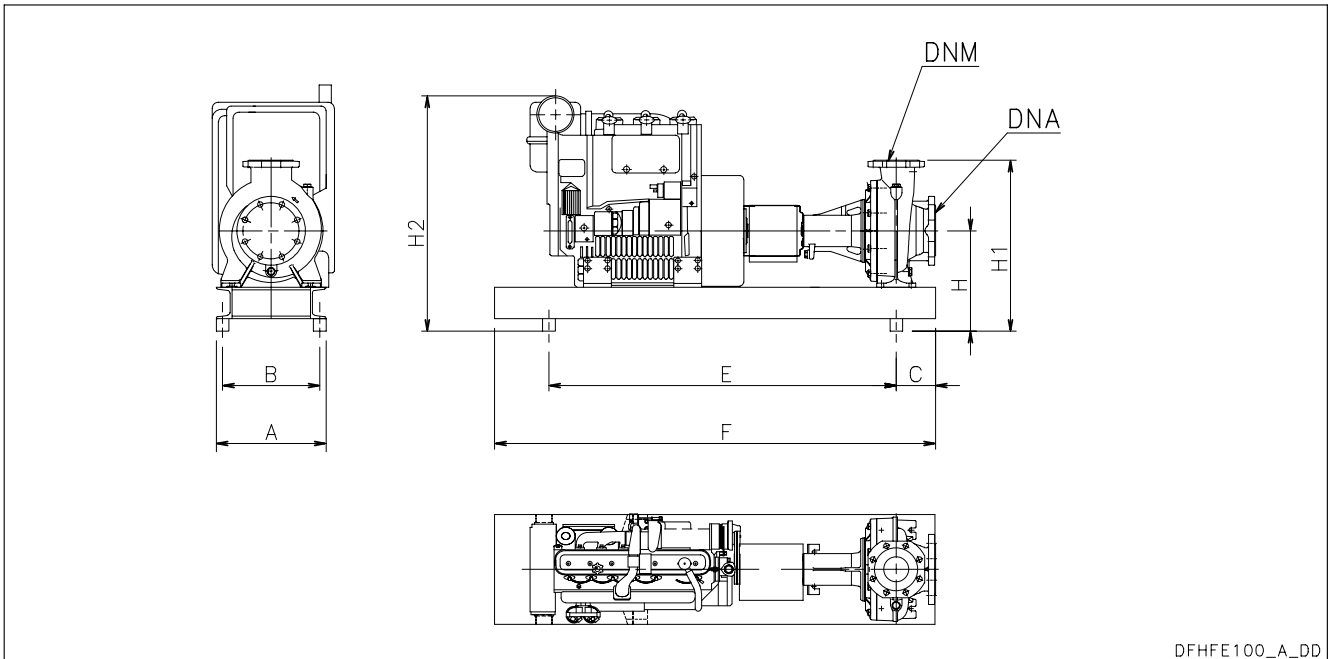

DFHFE100_A_DD

For the overall dimensions of the fuel tank and the starting batteries, see tables on pages 20-25.

DSHF 32-80 DIESEL ENGINE PUMP SERIES FIRE-FIGHTING EN 12845

D..	DNA	DNM	A	B	C	E	F	H	H1	H2
SHFE32-125/D121	R 2"	32	400	350	80	710	900	262	402	630
SHFE32-125/D136	R 2"	32	400	350	80	710	900	262	402	630
SHFE32-160/D150	R 2"	32	400	350	80	690	900	282	442	650
SHFE32-160/D168	R 2"	32	400	350	80	690	900	282	442	650
SHFE32-200/D188	R 2"	32	400	350	80	690	900	260	440	630
SHFE32-200/D204	R 2"	32	500	450	80	790	950	260	440	630
SHFE32-250/D222	R 2"	32	500	450	100	805	950	280	505	680
SHFE32-250/D242	R 2"	32	500	450	100	805	950	280	505	690
SHFE32-250/D256	R 2"	32	500	450	100	720	1000	280	505	690
SHFE40-125/D112	65	40	400	350	80	690	900	262	402	630
SHFE40-125/D126	65	40	400	350	80	690	900	262	402	630
SHFE40-125/D143	65	40	400	350	80	690	900	262	402	630
SHFE40-160/D159	65	40	400	350	80	690	900	282	442	650
SHFE40-160/D171	65	40	400	350	80	690	900	282	442	650
SHFE40-200/D190	65	40	500	450	100	770	950	310	490	710
SHFE40-200/D209	65	40	500	450	100	770	950	310	490	720
SHFE40-250/D218	65	40	530	480	100	820	1000	280	505	690
SHFE40-250/D233	65	40	530	480	100	920	1200	330	555	800
SHFE40-250/D251	65	40	530	480	100	920	1200	330	555	800
SHFE50-125/D119	65	50	400	350	100	690	950	282	442	650
SHFE50-125/D130	65	50	400	350	100	690	950	282	442	650
SHFE50-125/D139	65	50	500	450	100	740	950	282	442	650
SHFE50-160/D158	65	50	500	450	100	770	950	310	490	710
SHFE50-160/D174	65	50	500	450	100	770	950	310	490	720
SHFE50-200/D197	65	50	530	480	100	820	1000	310	510	720
SHFE50-200/D209	65	50	530	480	100	820	1200	310	510	720
SHFE50-250/D224	65	50	530	480	100	920	1200	330	555	800
SHFE50-250/D237	65	50	530	480	100	970	1350	380	555	800
SHFE50-250/D250	65	50	530	480	100	970	1350	380	605	800
SHFE65-160/D119	80	65	500	450	100	755	950	260	460	630
SHFE65-160/D129	80	65	500	450	100	805	950	310	510	710
SHFE65-160/D137	80	65	530	480	100	855	1000	310	510	720
SHFE65-160/D168	80	65	530	480	100	820	1000	310	510	720
SHFE65-160/D177	80	65	530	480	100	920	1200	360	560	830
SHFE65-200/D192	80	65	530	480	100	920	1200	330	555	800
SHFE65-200/D203	80	65	530	480	100	970	1350	380	555	800
SHFE65-200/D215	80	65	530	480	100	970	1350	380	605	900
SHFE65-250/D240	80	65	640	590	100	1130	1550	360	610	1000
SHFE65-250/D255	80	65	640	590	100	1130	1550	360	610	1010
SHFE80-160/D169	100	80	530	480	125	920	1250	330	555	800
SHFE80-160/D177	100	80	530	480	125	920	1250	330	555	800
SHFE80-160/D186	100	80	530	480	125	970	1350	380	605	800
SHFE80-200/D198	100	80	530	480	125	970	1450	380	630	900
SHFE80-200/D215	100	80	640	590	125	1095	1550	360	610	1000
SHFE80-200/D226	100	80	640	590	125	1095	1550	360	610	1010
SHFE80-250/D237	100	80	640	590	125	1180	1550	365	645	1030
SHFE80-250/D252	100	80	660	610	125	1240	1750	390	670	1080
SHFE80-250/D270	100	80	700	650	125	1310	2050	420	700	1090

Dimensions in mm. Tolerance ± 10 mm.

d_shfe-en_f_td

**Fire-fighting
booster sets
EN 12845**

MARKET SECTORS

CIVIL, INDUSTRIAL

APPLICATIONS

- Fixed fire-fighting systems.
Automatic Sprinkler systems.

**GEN..00D/SHF
Series**

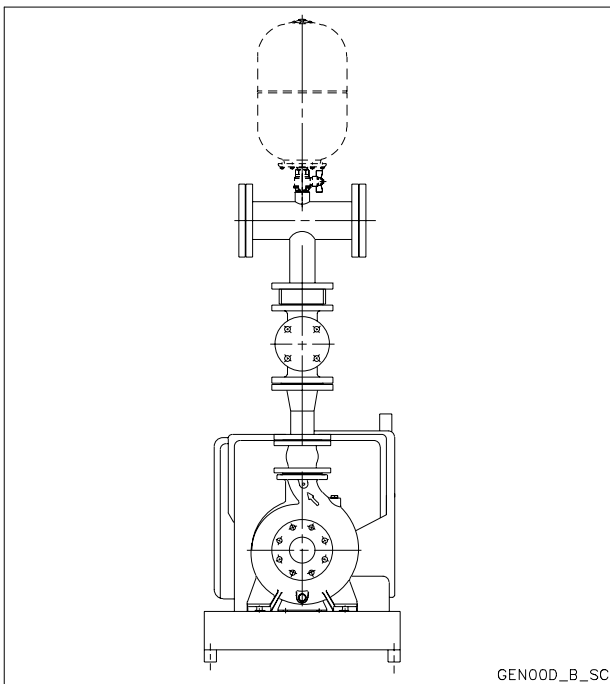

SPECIFICATIONS

- **Flow** up to 220 m³/h.
- **Head** up to 100 m.
- Panel supply power voltage:
1 x 230V ± 10%.
- Frequency: 50 Hz.
- Voltage for controls outside panel:
12 - 24 Vac.
- Protection grade:
- electric panel: IP54.
- Electric pumps maximum power
75 kW.
- Diesel engine with battery start.
- **Diesel engine service pump
in horizontal design:**
- SHF series.
- Maximum running pressure: 12 bar.

**GEN..00D/SHF 32-80 SERIES
FIRE-FIGHTING BOOSTER SETS EN 12845**

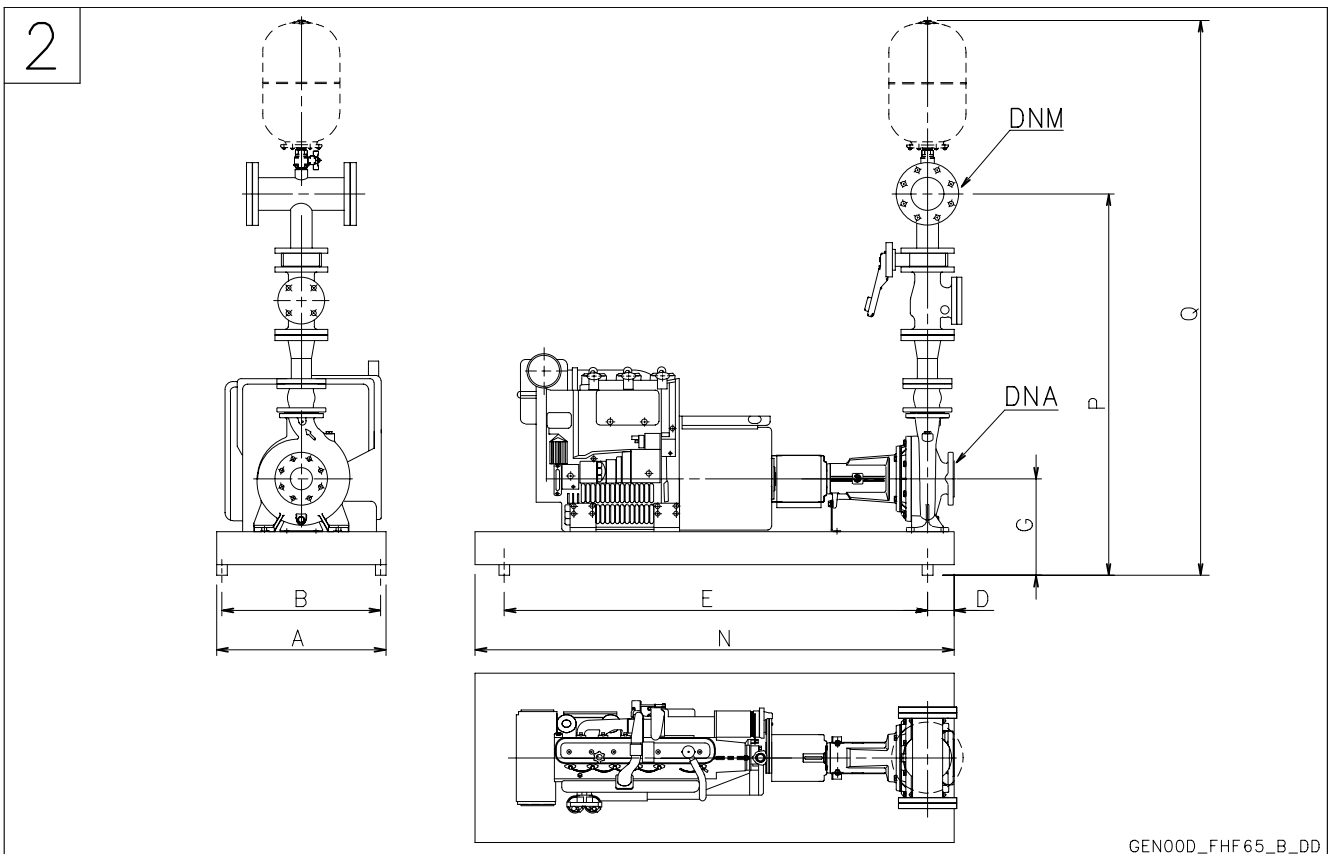
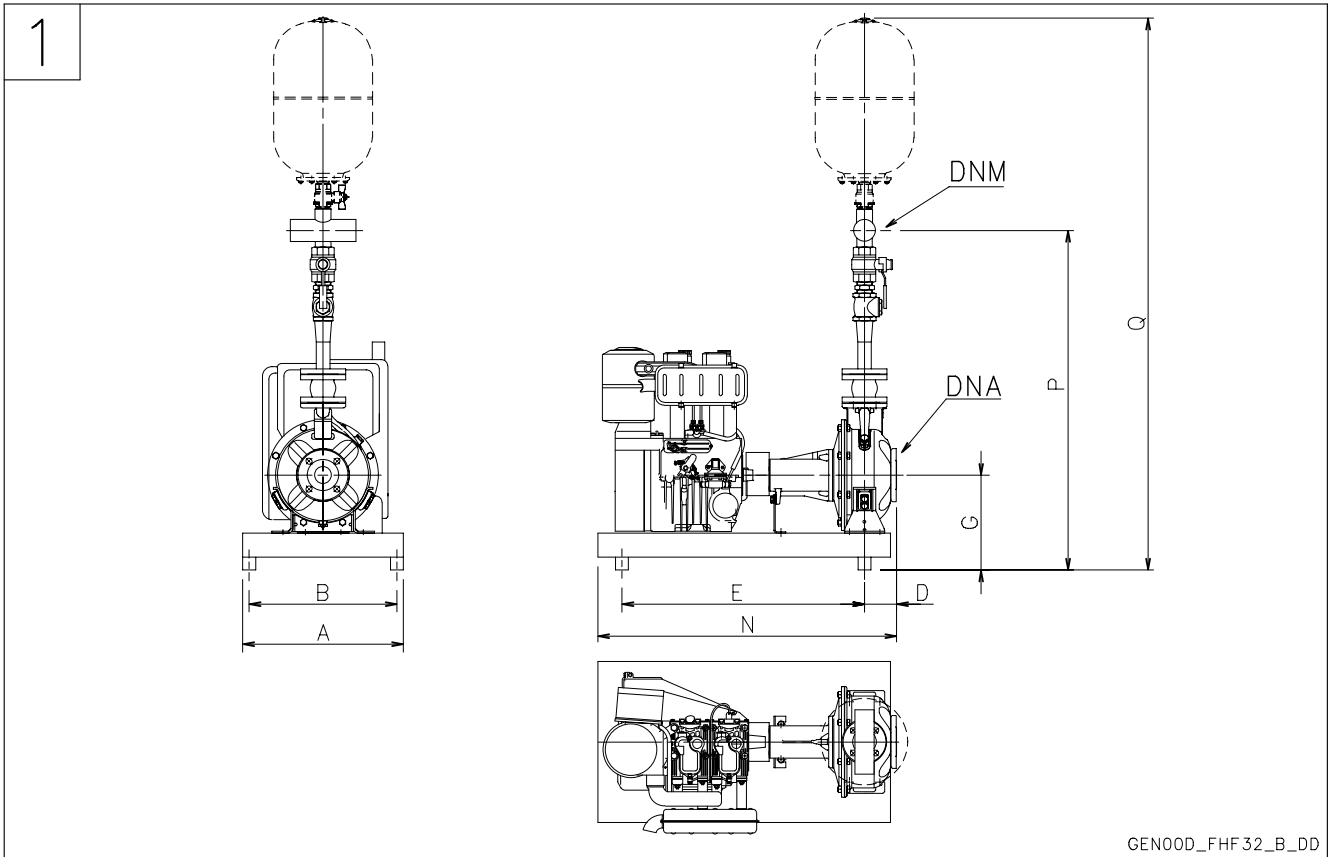

For the overall dimensions of the fuel tank and the starting batteries, see tables on pages 20-25.

GEN..00D/SHF 32-80 SERIES FIRE-FIGHTING BOOSTER SETS EN 12845

GEN..00D	DRW N°	DNA	DNM	A	B	D	E	G	N	P	Q
SHF32-125/D121	1	R 2"	R 1"1/2	400	350	80	710	262	900	913	1487
SHF32-125/D136	1	R 2"	R 1"1/2	400	350	80	710	262	900	913	1487
SHF32-160/D150	1	R 2"	R 1"1/2	400	350	80	690	282	900	953	1527
SHF32-160/D168	1	R 2"	R 1"1/2	400	350	80	690	282	900	953	1527
SHF32-200/D188	1	R 2"	R 1"1/2	400	350	80	690	260	900	951	1525
SHF32-200/D204	1	R 2"	R 1"1/2	500	450	80	790	260	950	951	1525
SHF32-250/D222	1	R 2"	R 1"1/2	500	450	100	805	280	950	1016	1590
SHF32-250/D242	1	R 2"	R 1"1/2	500	450	100	805	280	950	1016	1590
SHF32-250/D256	1	R 2"	R 1"1/2	500	450	100	720	280	1000	1016	1590
SHF40-125/D112	2	65	65	400	350	80	690	262	900	1106	1694
SHF40-125/D126	2	65	65	400	350	80	690	262	900	1106	1694
SHF40-125/D143	2	65	65	400	350	80	690	262	900	1106	1694
SHF40-160/D159	2	65	65	400	350	80	690	282	900	1146	1734
SHF40-160/D171	2	65	65	400	350	80	690	282	900	1146	1734
SHF40-200/D190	2	65	65	500	450	100	770	310	950	1194	1782
SHF40-200/D209	2	65	65	500	450	100	770	310	950	1194	1782
SHF40-250/D218	2	65	65	530	480	100	820	280	1000	1209	1797
SHF40-250/D233	2	65	65	530	480	100	920	330	1200	1259	1847
SHF40-250/D251	2	65	65	530	480	100	920	330	1200	1259	1847
SHF50-125/D119	2	65	65	400	350	100	690	282	950	1238	1826
SHF50-125/D130	2	65	65	400	350	100	690	282	950	1238	1826
SHF50-125/D139	2	65	65	500	450	100	740	282	950	1238	1826
SHF50-160/D158	2	65	65	500	450	100	770	310	950	1286	1874
SHF50-160/D174	2	65	65	500	450	100	770	310	950	1286	1874
SHF50-200/D197	2	65	65	530	480	100	820	310	1000	1306	1894
SHF50-200/D209	2	65	65	530	480	100	820	310	1200	1306	1894
SHF50-250/D224	2	65	65	530	480	100	920	330	1200	1351	1939
SHF50-250/D237	2	65	65	530	480	100	970	380	1350	1401	1989
SHF50-250/D250	2	65	65	530	480	100	970	380	1350	1401	1989
SHF65-160/D119	2	80	80	500	450	100	755	260	950	1323	1917
SHF65-160/D129	2	80	80	500	450	100	805	310	950	1373	1967
SHF65-160/D137	2	80	80	530	480	100	855	310	1000	1373	1967
SHF65-160/D168	2	80	80	530	480	100	820	310	1000	1373	1967
SHF65-160/D177	2	80	80	530	480	100	920	360	1200	1423	2017
SHF65-200/D192	2	80	80	530	480	100	920	330	1200	1418	2012
SHF65-200/D203	2	80	80	530	480	100	970	380	1350	1468	2062
SHF65-200/D215	2	80	80	530	480	100	970	380	1350	1493	2087
SHF65-250/D240	2	80	80	640	590	100	1130	360	1550	1473	2067
SHF65-250/D255	2	80	80	640	590	100	1130	360	1550	1473	2067
SHF80-160/D169	2	100	100	530	480	125	920	330	1250	1501	2108
SHF80-160/D177	2	100	100	530	480	125	920	330	1250	1501	2108
SHF80-160/D186	2	100	100	530	480	125	970	380	1350	1551	2158
SHF80-200/D198	2	100	100	530	480	125	970	380	1450	1576	2183
SHF80-200/D215	2	100	100	640	590	125	1095	360	1550	1556	2163
SHF80-200/D226	2	100	100	640	590	125	1095	360	1550	1556	2163
SHF80-250/D237	2	100	100	640	590	125	1180	365	1550	1591	2198
SHF80-250/D252	2	100	100	660	610	125	1240	390	1750	1616	2223
SHF80-250/D270	2	100	100	700	650	125	1310	420	2050	1646	2253

Dimensions in mm. Tolerance ± 10 mm.

gen00d_shf-en_h_td

**Fire-fighting
booster sets
EN 12845**

MARKET SECTORS
CIVIL, INDUSTRIAL

APPLICATIONS

- Fixed fire-fighting systems.
Automatic Sprinkler systems.

**GEN..01D/SHF
Series**

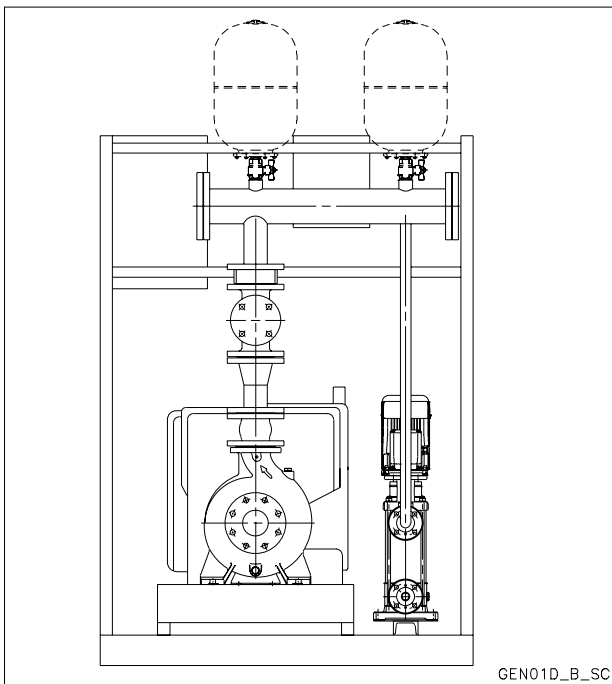

SPECIFICATIONS

- **Flow** up to 220 m³/h.
- **Head** up to 100 m.
- Panel supply power voltage:
 - Electric pump: 1 x 230V ± 10%.
 - Diesel engine pump: 1 x 230V ± 10%.
- Frequency: 50 Hz.
- Voltage for controls outside panel: 12 - 24 Vac.
- Protection grade:
 - electric panel: IP54.
- Electric pumps maximum power 75 kW.
- Electric motor start :
 - Direct start for powers up to 22 kW included for electric pump.
 - Diesel engine with battery start.
- **Service pump in horizontal design:**
 - SHF series.
- **Electric jockey pump with vertical axis:**
 - SV Series (motor protection grade IP55).
- Maximum running pressure: 12 bar.

**GEN..01D/SHF 32-80 SERIES
FIRE-FIGHTING BOOSTER SETS EN 12845**

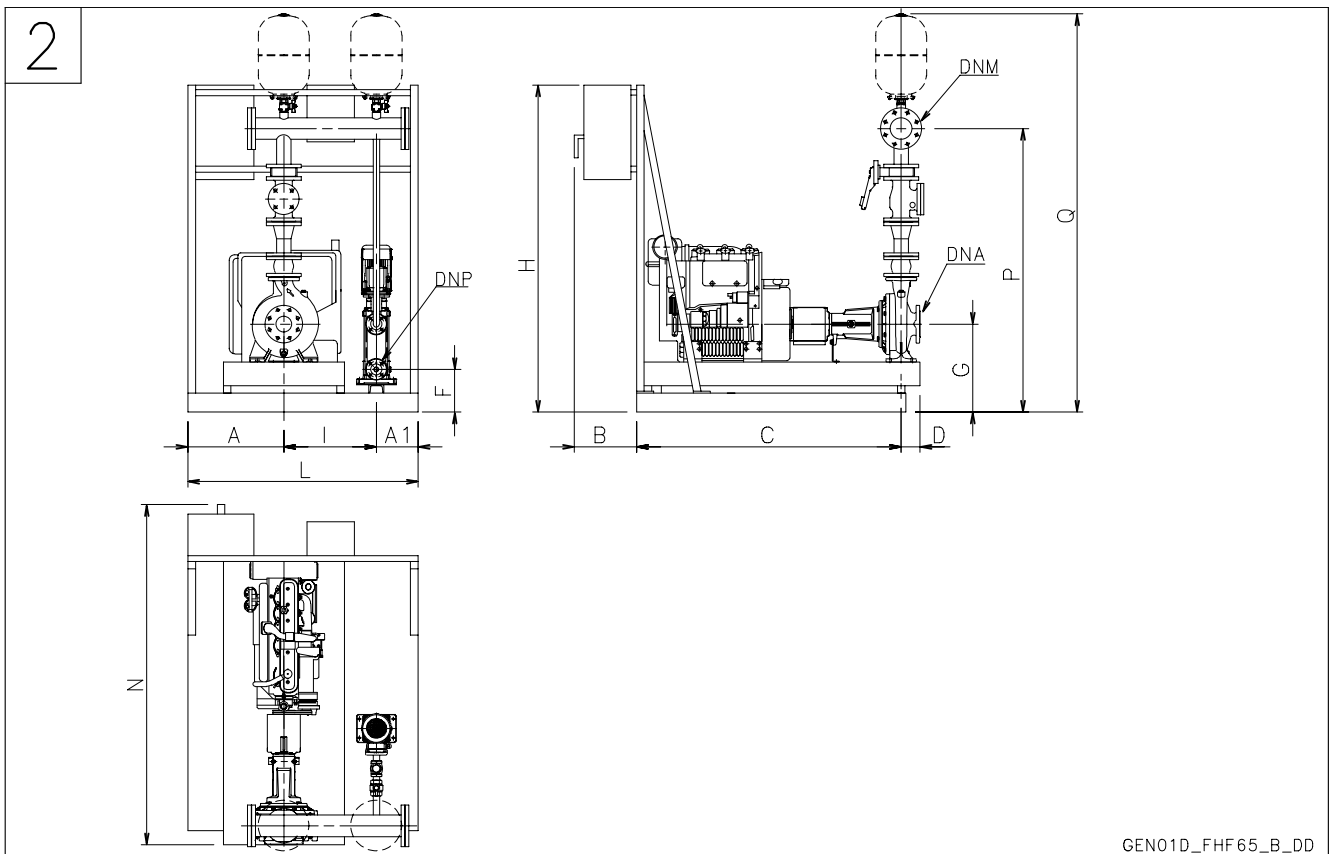
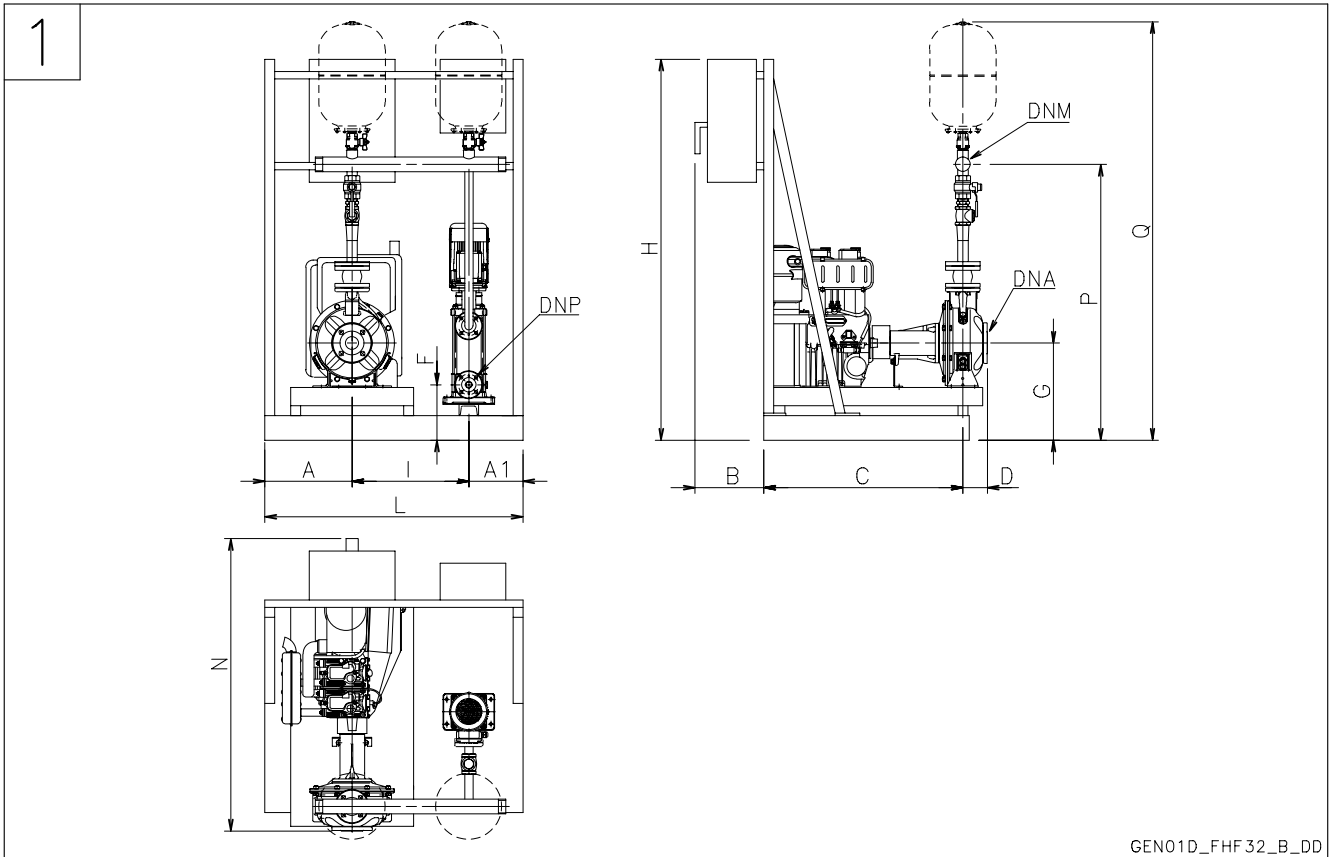

GEN..D/SHF

For the overall dimensions of the fuel tank and the starting batteries, see tables on pages 20-25.

GEN..01D/SHF 32-80 SERIES FIRE-FIGHTING BOOSTER SETS EN 12845

GEN..01D	DRW N°	DNA	DNP	DNM	A	A1	B	C	D	F	G	H	I	L	N	P	Q
SHF32-125/D121	1	R 2"	Rp 1"	R 1"1/2	330	220	280	905	80	225	362	1400	400	950	1265	1013	1587
SHF32-125/D136	1	R 2"	Rp 1"	R 1"1/2	330	220	280	905	80	225	362	1400	400	950	1265	1013	1587
SHF32-160/D150	1	R 2"	Rp 1"	R 1"1/2	330	220	280	885	80	225	382	1400	400	950	1245	1053	1627
SHF32-160/D168	1	R 2"	Rp 1"	R 1"1/2	330	220	280	885	80	225	382	1400	400	950	1245	1053	1627
SHF32-200/D188	1	R 2"	Rp 1"	R 1"1/2	330	220	280	885	80	225	360	1400	400	950	1245	1051	1625
SHF32-200/D204	1	R 2"	Rp 1"	R 1"1/2	400	225	280	1005	80	225	360	1400	475	1100	1365	1051	1625
SHF32-250/D222	1	R 2"	Rp 1"	R 1"1/2	400	225	280	1020	100	225	380	1400	475	1100	1400	1116	1690
SHF32-250/D242	1	R 2"	Rp 1"	R 1"1/2	400	225	280	1020	100	225	380	1400	475	1100	1400	1116	1690
SHF32-250/D256	1	R 2"	Rp 1"	R 1"1/2	400	225	280	915	100	225	380	1400	475	1100	1295	1116	1690
SHF40-125/D112	2	65	Rp 1"	65	330	220	280	885	80	225	362	1400	400	950	1245	1206	1794
SHF40-125/D126	2	65	Rp 1"	65	330	220	280	885	80	225	362	1400	400	950	1245	1206	1794
SHF40-125/D143	2	65	Rp 1"	65	330	220	280	885	80	225	362	1400	400	950	1245	1206	1794
SHF40-160/D159	2	65	Rp 1"	65	330	220	280	885	80	225	382	1400	400	950	1245	1246	1834
SHF40-160/D171	2	65	Rp 1"	65	330	220	280	885	80	225	382	1400	400	950	1245	1246	1834
SHF40-200/D190	2	65	Rp 1"	65	400	225	280	985	100	225	410	1400	475	1100	1365	1294	1882
SHF40-200/D209	2	65	Rp 1"	65	400	225	280	985	100	225	410	1400	475	1100	1365	1294	1882
SHF40-250/D218	2	65	Rp 1"	65	390	235	280	975	100	225	380	1400	475	1100	1355	1309	1897
SHF40-250/D233	2	65	Rp 1"	65	390	235	280	1170	100	225	430	1400	475	1100	1550	1359	1947
SHF40-250/D251	2	65	Rp 1"	65	390	235	280	1170	100	225	430	1400	475	1100	1550	1359	1947
SHF50-125/D119	2	65	Rp 1"	65	330	220	280	885	100	225	382	1400	400	950	1265	1338	1926
SHF50-125/D130	2	65	Rp 1"	65	330	220	280	885	100	225	382	1400	400	950	1265	1338	1926
SHF50-125/D139	2	65	Rp 1"	65	400	225	280	955	100	225	382	1400	475	1100	1335	1338	1926
SHF50-160/D158	2	65	Rp 1"	65	400	225	280	985	100	225	410	1400	475	1100	1365	1386	1974
SHF50-160/D174	2	65	Rp 1"	65	400	225	280	985	100	225	410	1400	475	1100	1365	1386	1974
SHF50-200/D197	2	65	Rp 1"	65	390	235	280	975	100	225	410	1400	475	1100	1355	1406	1994
SHF50-200/D209	2	65	Rp 1"	65	390	235	280	975	100	225	410	1400	475	1100	1355	1406	1994
SHF50-250/D224	2	65	Rp 1"	65	390	235	280	1170	100	225	430	1400	475	1100	1550	1451	2039
SHF50-250/D237	2	65	Rp 1"	65	390	235	280	1220	100	225	480	1550	475	1100	1600	1501	2089
SHF50-250/D250	2	65	Rp 1"	65	390	235	280	1220	100	225	480	1550	475	1100	1600	1501	2089
SHF65-160/D119	2	80	Rp 1"	80	400	225	280	970	100	225	360	1400	475	1100	1350	1423	2017
SHF65-160/D129	2	80	Rp 1"	80	400	225	280	1020	100	225	410	1400	475	1100	1400	1473	2067
SHF65-160/D137	2	80	Rp 1"	80	390	235	280	1105	100	225	410	1400	475	1100	1485	1473	2067
SHF65-160/D168	2	80	Rp 1"	80	390	235	280	975	100	225	410	1400	475	1100	1355	1473	2067
SHF65-160/D177	2	80	Rp 1"	80	390	235	280	1170	100	225	460	1400	475	1100	1550	1523	2117
SHF65-200/D192	2	80	Rp 1"	80	390	235	280	1170	100	225	430	1400	475	1100	1550	1518	2112
SHF65-200/D203	2	80	Rp 1"	80	390	235	280	1220	100	225	480	1550	475	1100	1600	1568	2162
SHF65-200/D215	2	80	Rp 1"	80	390	235	280	1220	100	225	480	1550	475	1100	1600	1593	2187
SHF65-250/D240	2	80	Rp 1"	80	460	380	180	1270	100	245	480	1750	530	1370	1550	1593	2187
SHF65-250/D255	2	80	Rp 1"	80	460	380	180	1270	100	245	480	1750	530	1370	1550	1593	2187
SHF80-160/D169	2	100	Rp 1"	100	390	235	280	1170	125	225	430	1400	475	1100	1575	1601	2208
SHF80-160/D177	2	100	Rp 1"	100	390	235	280	1170	125	225	430	1400	475	1100	1575	1601	2208
SHF80-160/D186	2	100	Rp 1"	100	390	235	280	1220	125	225	480	1550	475	1100	1625	1651	2258
SHF80-200/D198	2	100	Rp 1"	100	390	235	280	1370	125	225	480	1550	475	1100	1775	1676	2283
SHF80-200/D215	2	100	Rp 1"	100	500	270	280	1440	125	245	480	1750	530	1300	1845	1676	2283
SHF80-200/D226	2	100	Rp 1"	100	500	270	280	1440	125	245	480	1750	530	1300	1845	1676	2283
SHF80-250/D237	2	100	Rp 1"	100	505	265	280	1550	125	245	485	1750	530	1300	1955	1711	2318
SHF80-250/D252	2	100	Rp 1"	100	505	265	245	1380	125	265	530	1770	530	1300	1750	1756	2363
SHF80-250/D270	2	100	Rp 1"	100	550	265	575	1350	125	215	560	*	570	1385	2050	1786	2393

* Wall mounted control panel.

gen01d_shf-en_g_td

Dimensions in mm. Tolerance ± 10 mm.

**Fire-fighting
booster sets
EN 12845**

MARKET SECTORS

CIVIL, INDUSTRIAL

APPLICATIONS

- Fixed fire-fighting systems.
Automatic Sprinkler systems.

**Serie
GEN..10D/SHF**

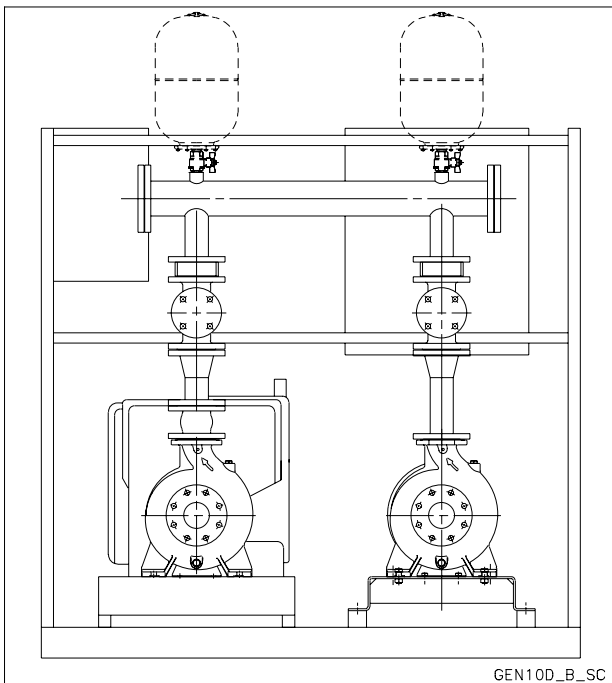

SPECIFICATIONS

- **Flow** up to 440 m³/h.
- **Head** up to 100 m.
- Panel supply power voltage:
 - Electric pump: 3 x 400V ± 10%.
 - Diesel engine pump: 1 x 230V ± 10%.
- Frequency: 50 Hz.
- Voltage for controls outside panel: 12 - 24 Vac.
- Protection grade:
 - electric panel: IP54.
- Electric pumps maximum power 75 kW.
- Electric motor start :
 - Direct start for powers up to 22 kW included for pump (GEND...).
 - Star/delta start for higher powers (GENY... set).
- Diesel engine with battery start.
- **Service pump in horizontal design:**
 - SHF series (IP55 electric motor protection).
- Maximum running pressure: 12 bar.

**GEN..10D/SHF 32-80 SERIES
FIRE-FIGHTING BOOSTER SETS EN 12845**

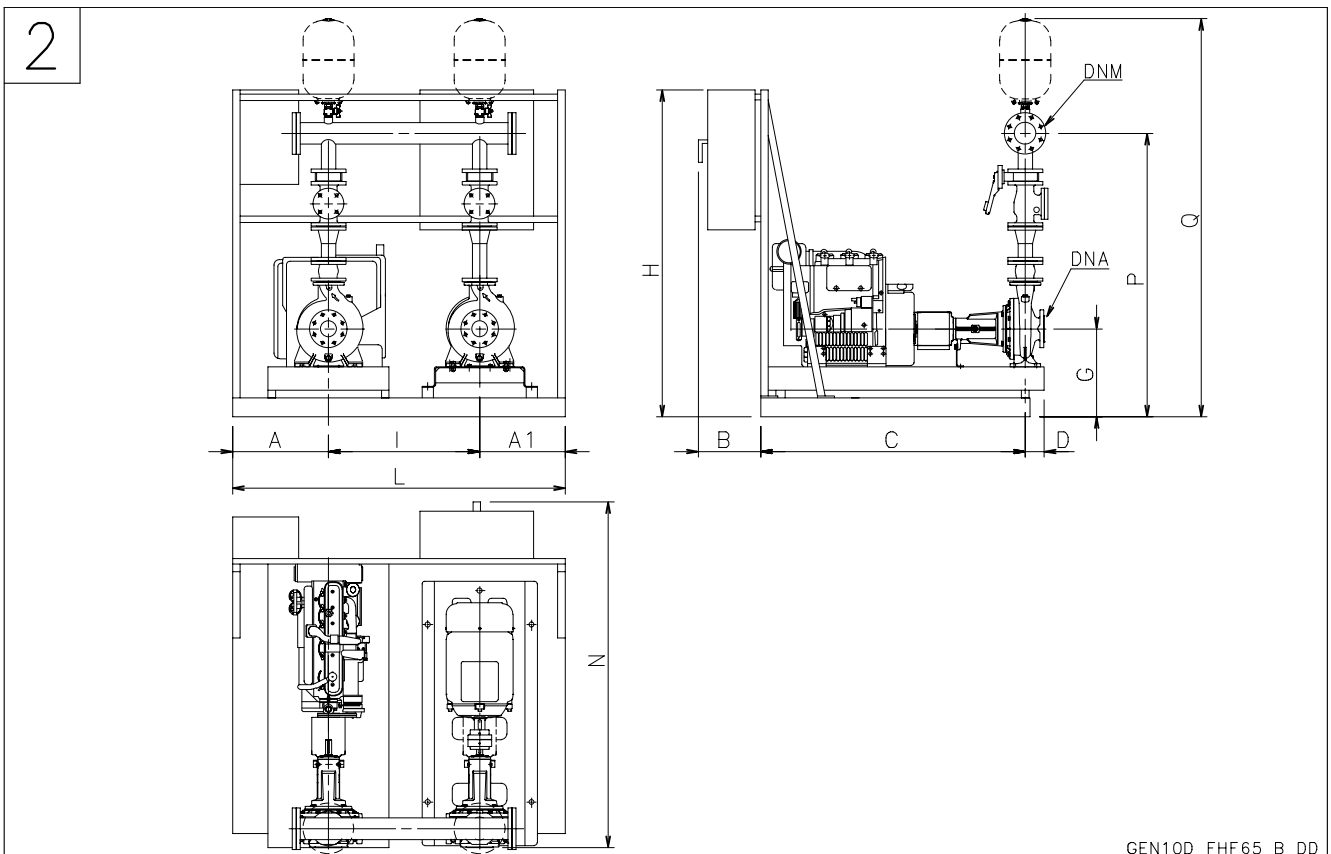
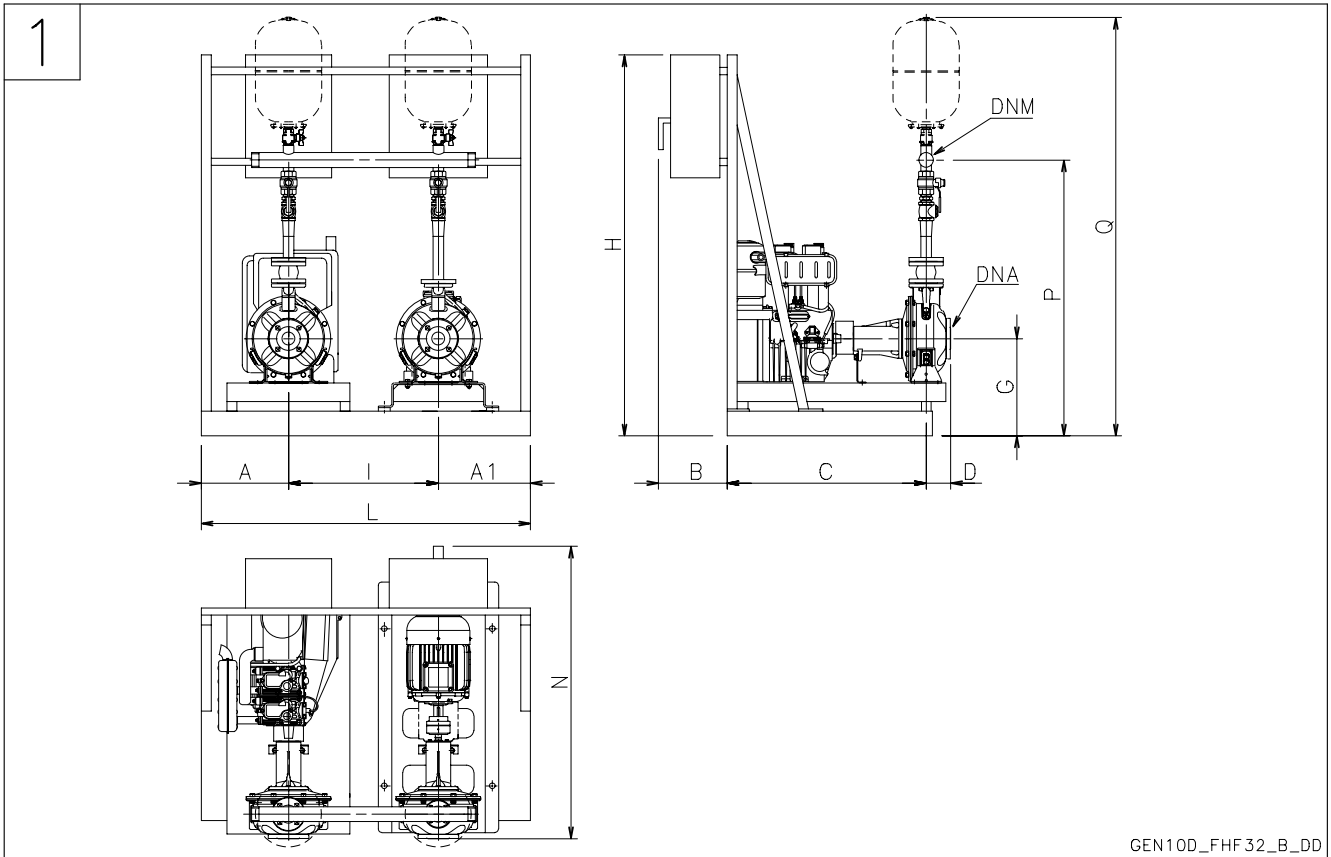

For the overall dimensions of the fuel tank and the starting batteries, see tables on pages 20-25.

GEN..D/SHF

GEN..10D/SHF 32-80 SERIES FIRE-FIGHTING BOOSTER SETS EN 12845

GEN..10D	DRW N°	DNA	DNM	A	A1	B	C	D	G	H	I	L	N	P	Q
SHF32-125/07/D121	1	R 2"	R 2"	320	310	240	870	80	362	1400	470	1100	1230	1019	1599
SHF32-125/11/D136	1	R 2"	R 2"	320	310	240	870	80	362	1400	470	1100	1230	1019	1599
SHF32-160/15/D150	1	R 2"	R 2"	320	310	240	850	80	382	1400	470	1100	1210	1059	1639
SHF32-160/22/D168	1	R 2"	R 2"	320	310	240	850	80	382	1400	470	1100	1210	1059	1639
SHF32-200/30/D188	1	R 2"	R 2"	320	310	240	850	80	360	1400	470	1100	1210	1057	1637
SHF32-200/40/D204	1	R 2"	R 2"	380	350	240	960	80	360	1400	570	1300	1320	1057	1637
SHF32-250/55/D222	1	R 2"	R 2"	380	350	240	1025	100	380	1400	570	1300	1405	1122	1702
SHF32-250/75/D242	1	R 2"	R 2"	380	350	240	1025	100	380	1400	570	1300	1405	1122	1702
SHF32-250/110/D256	1	R 2"	R 2"	420	370	280	995	100	380	1400	610	1400	1375	1122	1702
SHF40-125/11/D112	2	65	65	320	310	240	850	80	362	1400	470	1100	1210	1206	1794
SHF40-125/15/D126	2	65	65	320	310	240	850	80	362	1400	470	1100	1210	1206	1794
SHF40-125/22/D143	2	65	65	320	310	240	850	80	362	1400	470	1100	1210	1206	1794
SHF40-160/30/D159	2	65	65	320	310	240	850	80	382	1400	470	1100	1210	1246	1834
SHF40-160/40/D171	2	65	65	320	310	240	850	80	382	1400	470	1100	1210	1246	1834
SHF40-200/55/D190	2	65	65	380	350	240	940	100	410	1400	570	1300	1320	1294	1882
SHF40-200/75/D209	2	65	65	380	350	240	940	100	410	1400	570	1300	1320	1294	1882
SHF40-250/110A/D218	2	65	65	420	370	180	1145	100	380	1400	610	1400	1425	1309	1897
SHF40-250/110/D233	2	65	65	420	370	280	1225	100	430	1400	610	1400	1605	1359	1947
SHF40-250/150/D251	2	65	65	420	370	280	1225	100	430	1400	610	1400	1605	1359	1947
SHF50-125/22/D119	2	65	80	320	310	240	850	100	382	1400	470	1100	1230	1345	1939
SHF50-125/30/D130	2	65	80	320	310	240	850	100	382	1400	470	1100	1230	1345	1939
SHF50-125/40/D139	2	65	80	380	350	240	910	100	382	1400	570	1300	1290	1345	1939
SHF50-160/55/D158	2	65	80	380	350	240	940	100	410	1400	570	1300	1320	1393	1987
SHF50-160/75/D174	2	65	80	380	350	240	940	100	410	1400	570	1300	1320	1393	1987
SHF50-200/110A/D197	2	65	80	420	370	130	1080	100	410	1400	610	1400	1460	1413	2007
SHF50-200/110/D209	2	65	80	420	370	205	1080	100	410	1400	610	1400	1460	1413	2007
SHF50-250/150/D224	2	65	80	415	375	280	1225	100	430	1400	610	1400	1605	1458	2052
SHF50-250/185/D237	2	65	80	420	370	280	1275	100	480	1550	610	1400	1655	1508	2102
SHF50-250/220/D250	2	65	80	420	370	280	1275	100	480	1550	610	1400	1655	1508	2102
SHF65-160/40/D119	2	80	100	380	350	240	925	100	360	1400	570	1300	1305	1435	2042
SHF65-160/55/D129	2	80	100	380	350	240	975	100	410	1400	570	1300	1355	1485	2092
SHF65-160/75/D137	2	80	100	420	370	240	1065	100	410	1400	570	1360	1445	1485	2092
SHF65-160/110A/D168	2	80	100	420	370	180	1145	100	410	1400	610	1400	1425	1485	2092
SHF65-160/110/D177	2	80	100	415	375	280	1225	100	460	1400	610	1400	1605	1535	2142
SHF65-200/150/D192	2	80	100	415	375	280	1225	100	430	1400	610	1400	1605	1530	2137
SHF65-200/185/D203	2	80	100	420	370	280	1275	100	480	1550	610	1400	1655	1580	2187
SHF65-200/220/D215	2	80	100	420	370	280	1275	100	480	1550	610	1400	1655	1605	2212
SHF65-250/300/D240	2	80	100	480	450	290	1450	100	480	1750	730	1660	1840	1605	2212
SHF65-250/370/D255	2	80	100	480	450	290	1450	100	480	1750	730	1660	1840	1605	2212
SHF80-160/110/D169	2	100	125	415	375	280	1225	125	430	1400	610	1400	1630	1614	2234
SHF80-160/150/D177	2	100	125	415	375	280	1225	125	430	1400	610	1400	1630	1614	2234
SHF80-160/185/D186	2	100	125	420	370	280	1275	125	480	1550	610	1400	1680	1664	2284
SHF80-200/220/D198	2	100	125	420	370	330	1275	125	480	1550	610	1400	1730	1689	2309
SHF80-200/300/D215	2	100	125	480	450	300	1415	125	480	1750	730	1660	1840	1689	2309
SHF80-200/370/D226	2	100	125	480	450	300	1415	125	480	1750	730	1660	1840	1689	2309
SHF80-250/450/D237	2	100	125	480	450	320	1450	125	485	1750	730	1660	1895	1724	2344
SHF80-250/550/D252	2	100	125	480	450	355	1505	125	530	1770	730	1660	1985	1769	2389
SHF80-250/750/D270	2	100	125	550	555	555	1450	125	560	*	800	1905	2150	1799	2419

* Wall mounted control panel.

gen10d_shf-en_f_td

Dimensions in mm. Tolerance \pm 10 mm.

**Fire-fighting
booster sets
EN 12845**

MARKET SECTORS

CIVIL, INDUSTRIAL

APPLICATIONS

- Fixed fire-fighting systems.
Automatic Sprinkler systems.

**GEN..11D/SHF
Series**

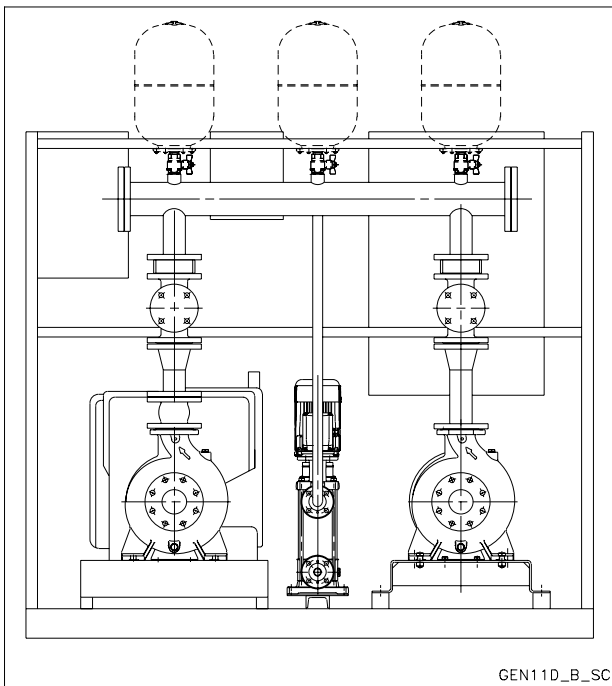

SPECIFICATIONS

- **Flow** up to 440 m³/h.
- **Head** up to 100 m.
- Panel supply power voltage:
 - Electric pump: 3 x 400V ± 10%.
 - Diesel engine pump: 1 x 230V ± 10%.
- Frequency: 50 Hz.
- Voltage for controls outside panel: 12 - 24 Vac.
- Protection grade:
 - electric panel: IP54.
- Electric pumps maximum power 75 kW.
- Electric motor start :
 - Direct start for powers up to 22 kW included for pump (GEND...).
 - Star/delta start for higher powers (GENY... set).
- Diesel engine with battery start.
- **Service pump in horizontal design:**
 - SHF series (IP55 electric motor protection).
- **Electric jockey pump with vertical axis:**
 - SV Series (motor protection grade IP55).
- Maximum running pressure: 12 bar.

**GEN..11D/SHF 32-80 SERIES
FIRE-FIGHTING BOOSTER SETS EN 12845**

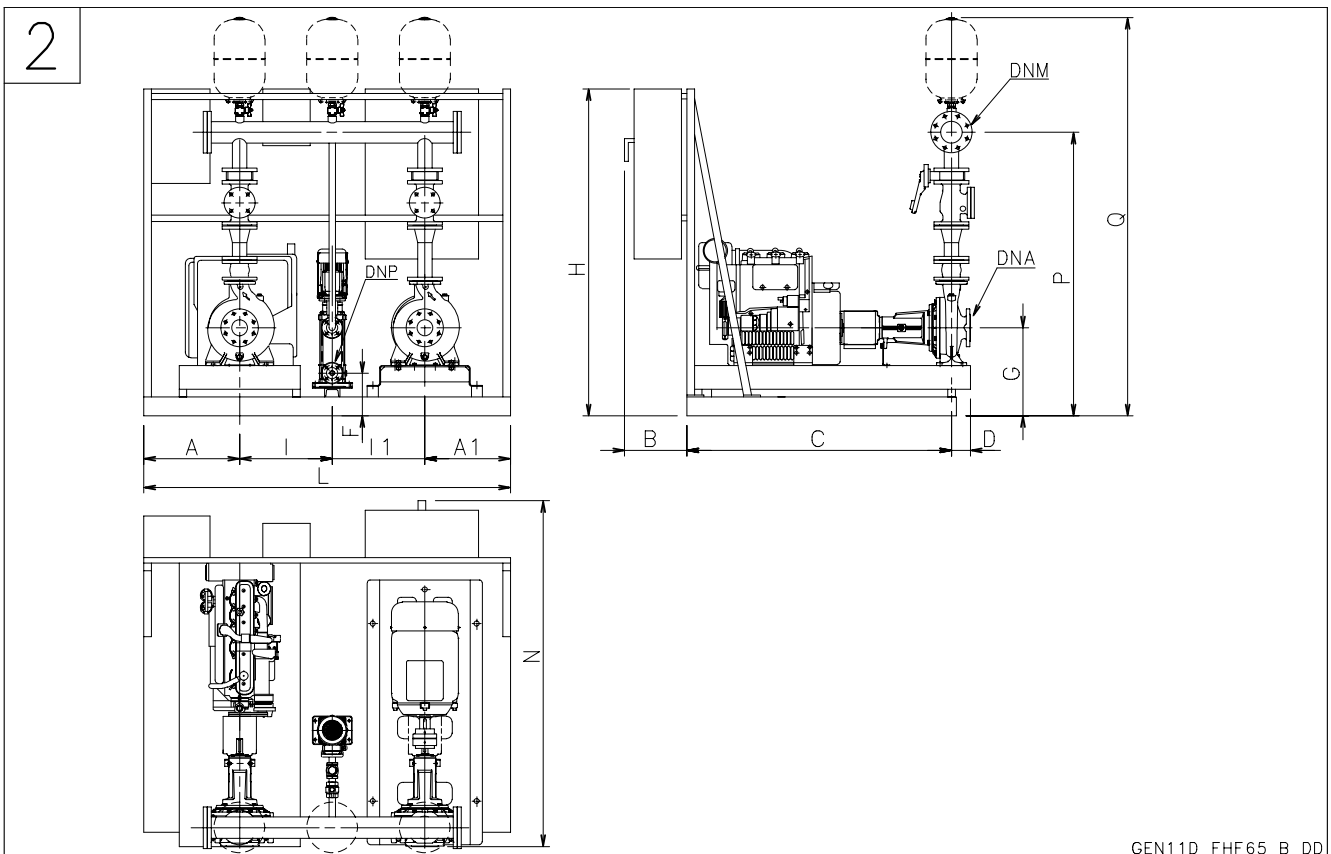
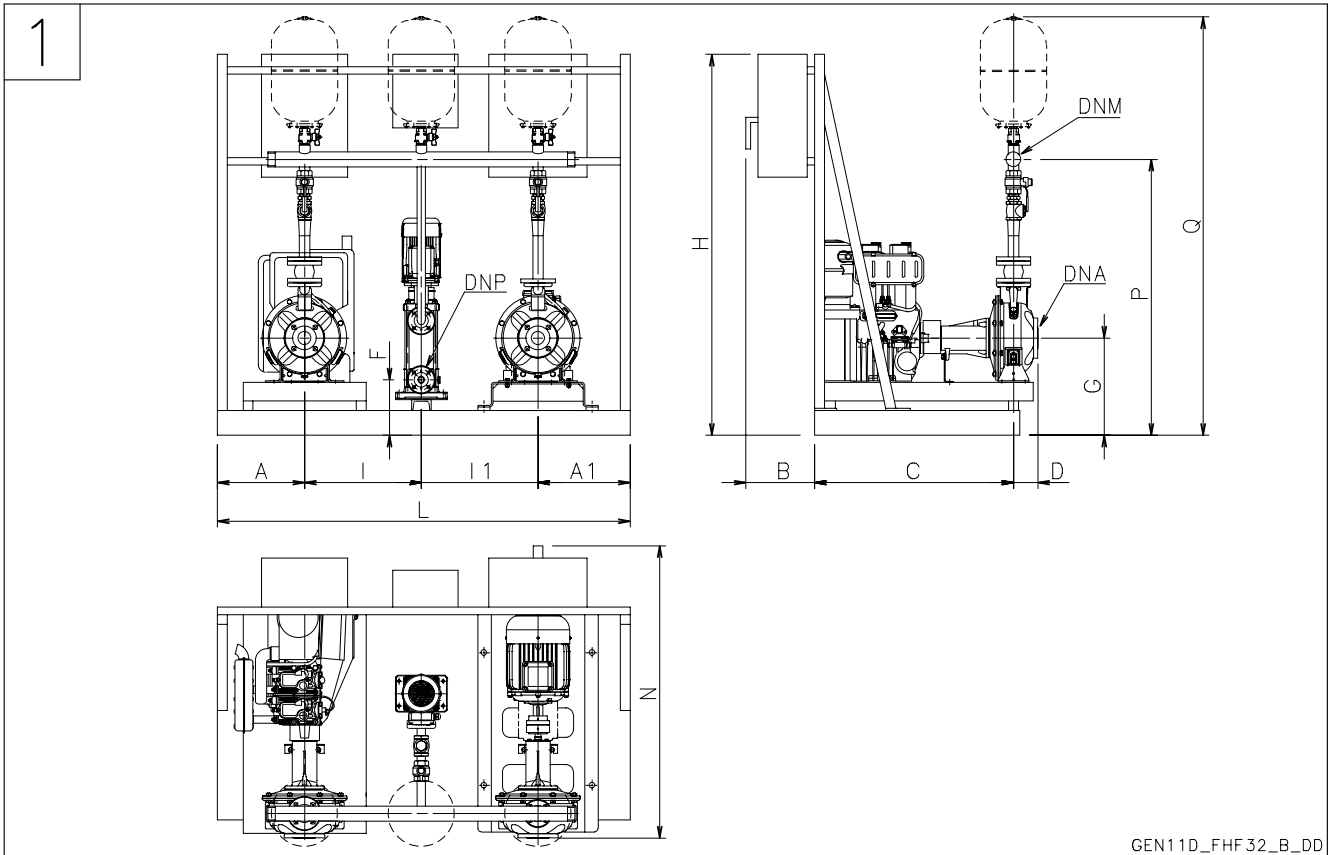

For the overall dimensions of the fuel tank and the starting batteries, see tables on pages 20-25.

GEN..D/SHF

**GEN..11D/SHF 32-80 SERIES
FIRE-FIGHTING BOOSTER SETS EN 12845**

GEN..11D	DRW N°	DNA	DNP	DNM	A	A1	B	C	D	F	G	H	I	I1	L	N	P	Q
SHF32-125/07/D121	1	R 2"	Rp 1"	R 2"	305	295	240	905	80	225	362	1400	400	400	1400	1225	1019	1599
SHF32-125/11/D136	1	R 2"	Rp 1"	R 2"	305	295	240	905	80	225	362	1400	400	400	1400	1225	1019	1599
SHF32-160/15/D150	1	R 2"	Rp 1"	R 2"	305	295	240	850	80	225	382	1400	400	400	1400	1170	1059	1639
SHF32-160/22/D168	1	R 2"	Rp 1"	R 2"	305	295	240	850	80	225	382	1400	400	400	1400	1170	1059	1639
SHF32-200/30/D188	1	R 2"	Rp 1"	R 2"	305	295	240	850	80	225	360	1400	400	400	1400	1170	1057	1637
SHF32-200/40/D204	1	R 2"	Rp 1"	R 2"	400	375	240	1005	80	225	360	1400	475	430	1680	1325	1057	1637
SHF32-250/55/D222	1	R 2"	Rp 1"	R 2"	355	375	240	1005	100	225	380	1400	475	475	1680	1345	1122	1702
SHF32-250/75/D242	1	R 2"	Rp 1"	R 2"	355	375	240	1005	100	225	380	1400	475	475	1680	1345	1122	1702
SHF32-250/110/D256	1	R 2"	Rp 1"	R 2"	355	375	280	1120	100	225	380	1400	475	475	1680	1500	1122	1702
SHF40-125/11/D112	2	65	Rp 1"	65	305	295	240	850	80	225	362	1400	400	400	1400	1170	1206	1794
SHF40-125/15/D126	2	65	Rp 1"	65	305	295	240	850	80	225	362	1400	400	400	1400	1170	1206	1794
SHF40-125/22/D143	2	65	Rp 1"	65	305	295	240	850	80	225	362	1400	400	400	1400	1170	1206	1794
SHF40-160/30/D159	2	65	Rp 1"	65	305	295	240	850	80	225	382	1400	400	400	1400	1170	1246	1834
SHF40-160/40/D171	2	65	Rp 1"	65	305	295	240	850	80	225	382	1400	400	400	1400	1170	1246	1834
SHF40-200/55/D190	2	65	Rp 1"	65	400	375	240	940	100	225	410	1400	475	430	1680	1280	1294	1882
SHF40-200/75/D209	2	65	Rp 1"	65	400	375	240	940	100	225	410	1400	475	430	1680	1280	1294	1882
SHF40-250/110A/D218	2	65	Rp 1"	65	365	355	180	995	100	225	380	1400	475	475	1670	1275	1309	1897
SHF40-250/110/D233	2	65	Rp 1"	65	375	385	280	995	100	225	430	1400	475	475	1710	1375	1359	1947
SHF40-250/150/D251	2	65	Rp 1"	65	375	385	280	995	100	225	430	1400	475	475	1710	1375	1359	1947
SHF50-125/22/D119	2	65	Rp 1"	80	305	295	240	850	100	225	382	1400	400	400	1400	1190	1345	1939
SHF50-125/30/D130	2	65	Rp 1"	80	305	295	240	850	100	225	382	1400	400	400	1400	1190	1345	1939
SHF50-125/40/D139	2	65	Rp 1"	80	400	375	240	1005	100	225	382	1400	475	430	1680	1345	1345	1939
SHF50-160/55/D158	2	65	Rp 1"	80	400	375	240	940	100	225	410	1400	475	430	1680	1280	1393	1987
SHF50-160/75/D174	2	65	Rp 1"	80	400	375	240	940	100	225	410	1400	475	430	1680	1280	1393	1987
SHF50-200/110A/D197	2	65	Rp 1"	80	385	345	130	895	100	225	410	1400	475	475	1680	1125	1413	2007
SHF50-200/110/D209	2	65	Rp 1"	80	385	345	205	895	100	225	410	1400	475	475	1680	1200	1413	2007
SHF50-250/150/D224	2	65	Rp 1"	80	375	385	280	995	100	225	430	1400	475	475	1710	1375	1458	2052
SHF50-250/185/D237	2	65	Rp 1"	80	400	395	280	995	100	225	480	1550	475	475	1745	1375	1508	2102
SHF50-250/220/D250	2	65	Rp 1"	80	400	395	280	995	100	225	480	1550	475	475	1745	1375	1508	2102
SHF65-160/40/D119	2	80	Rp 1"	100	400	375	240	925	100	225	360	1400	475	430	1680	1265	1435	2042
SHF65-160/55/D129	2	80	Rp 1"	100	390	365	240	975	100	225	410	1400	475	430	1660	1315	1485	2092
SHF65-160/75/D137	2	80	Rp 1"	100	385	330	240	1065	100	225	410	1400	475	430	1620	1405	1485	2092
SHF65-160/110A/D168	2	80	Rp 1"	100	365	355	180	995	100	225	410	1400	475	475	1670	1275	1485	2092
SHF65-160/110/D177	2	80	Rp 1"	100	375	385	280	995	100	225	460	1400	475	475	1710	1375	1535	2142
SHF65-200/150/D192	2	80	Rp 1"	100	375	385	280	995	100	225	430	1400	475	475	1710	1375	1530	2137
SHF65-200/185/D203	2	80	Rp 1"	100	400	395	280	995	100	225	480	1550	475	475	1745	1375	1580	2187
SHF65-200/220/D215	2	80	Rp 1"	100	400	395	280	995	100	225	480	1550	475	475	1745	1375	1605	2212
SHF65-250/300/D240	2	80	Rp 1"	100	470	435	290	1160	100	195	480	1750	530	490	1925	1550	1605	2212
SHF65-250/370/D255	2	80	Rp 1"	100	470	435	290	1160	100	195	480	1750	530	490	1925	1550	1605	2212
SHF80-160/110/D169	2	100	Rp 1"	125	375	385	280	995	125	225	430	1400	475	475	1710	1400	1614	2234
SHF80-160/150/D177	2	100	Rp 1"	125	375	385	280	995	125	225	430	1400	475	475	1710	1400	1614	2234
SHF80-160/185/D186	2	100	Rp 1"	125	400	395	280	995	125	225	480	1550	475	475	1745	1400	1664	2284
SHF80-200/220/D198	2	100	Rp 1"	125	400	395	330	995	125	225	480	1550	475	475	1745	1450	1689	2309
SHF80-200/300/D215	2	100	Rp 1"	125	470	435	300	1125	125	195	480	1750	530	490	1925	1550	1689	2309
SHF80-200/370/D226	2	100	Rp 1"	125	470	435	300	1125	125	195	480	1750	530	490	1925	1550	1689	2309
SHF80-250/450/D237	2	100	Rp 1"	125	470	395	320	1205	125	195	485	1750	530	490	1885	1650	1724	2344
SHF80-250/550/D252	2	100	Rp 1"	125	485	455	355	1270	125	215	530	1770	530	530	2000	1750	1769	2389
SHF80-250/750/D270	2	100	Rp 1"	125	585	540	555	1370	125	215	560	*	570	570	2265	2050	1799	2419

* Wall mounted control panel.

gen11d_shf-en_h_td

Dimensions in mm. Tolerance ± 10 mm.

**GEN..D/SHF SERIES OF BOOSTER SETS (POSITIVE SUCTION HEAD)
H_c PRESSURE DROP CURVE IN SUCTION KIT**

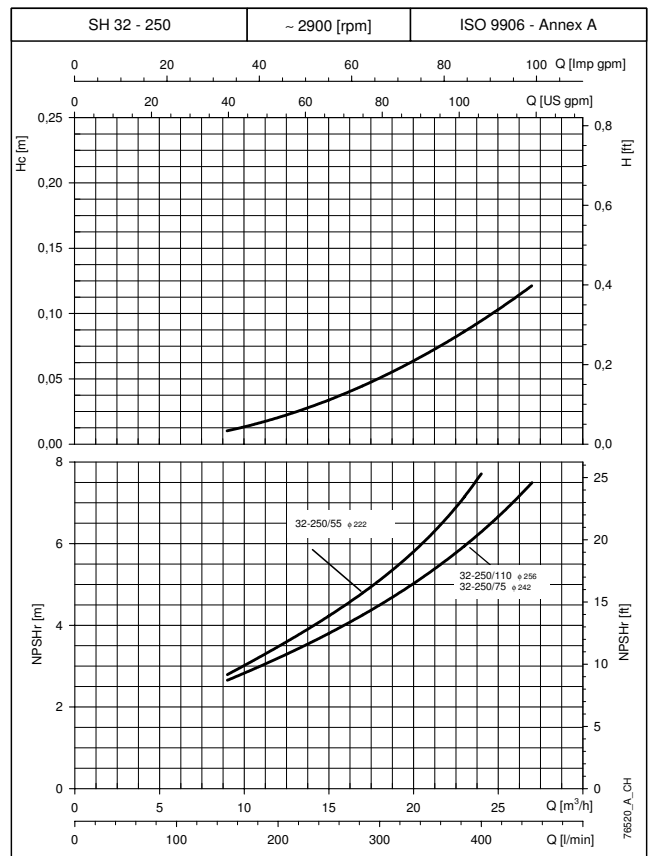
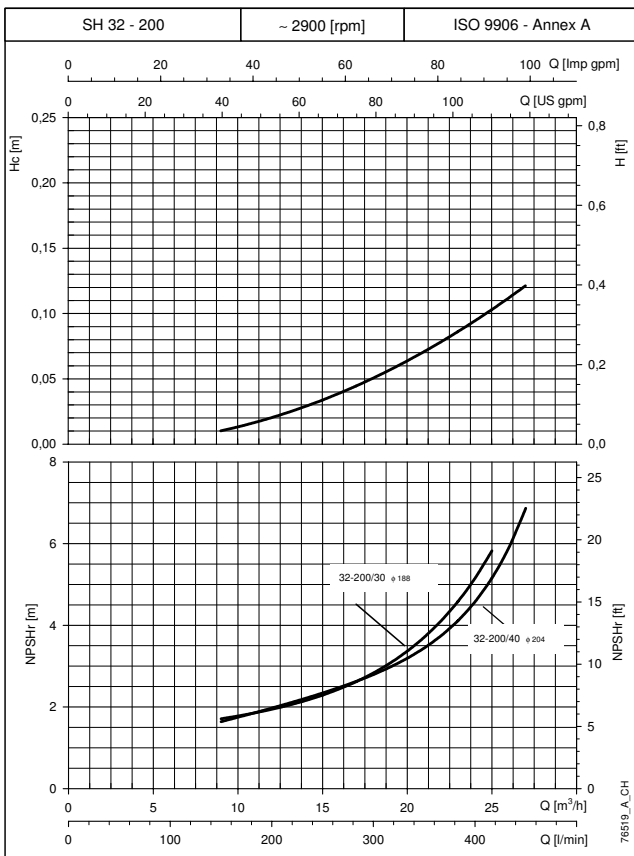
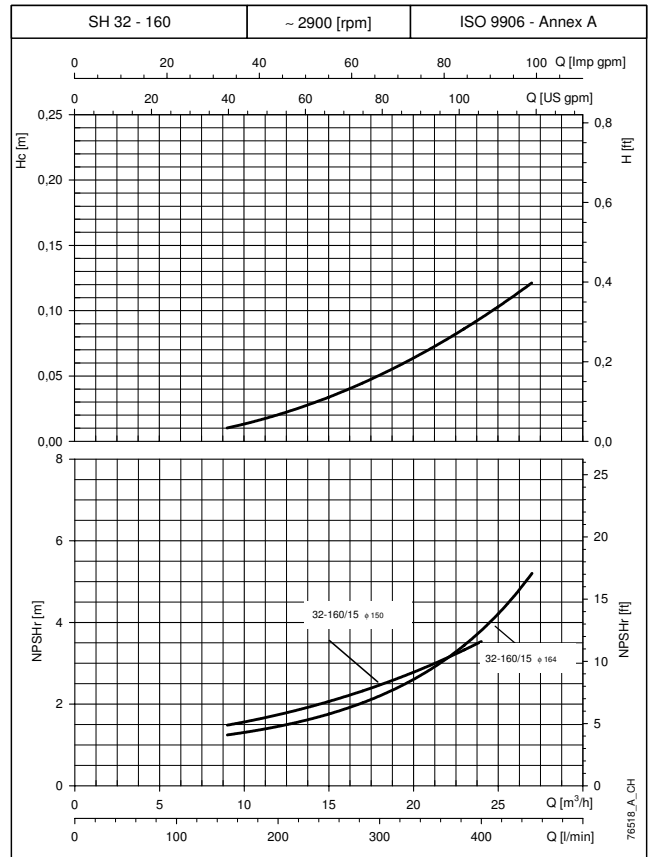
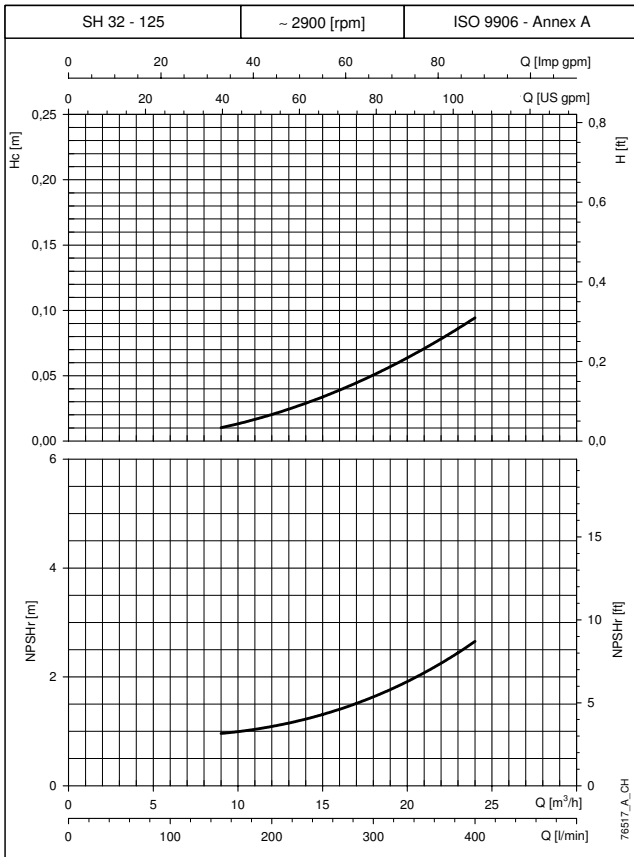

The declared performance value are valid for liquids with density $\rho = 1.0 \text{ Kg/dm}^3$ and kinematic viscosity $\nu = 1 \text{ mm}^2/\text{sec}$.
The NPSHr values required for the service pump were obtained in the laboratory. When using them for EN 12845 for fire-fighting systems, increase the value by 1 m.
H_c: Pressure drop curve in suction kit.

GEN..D/SHF

GEN..D/SHF SERIES OF BOOSTER SETS (POSITIVE SUCTION HEAD) H_c PRESSURE DROP CURVE IN SUCTION KIT

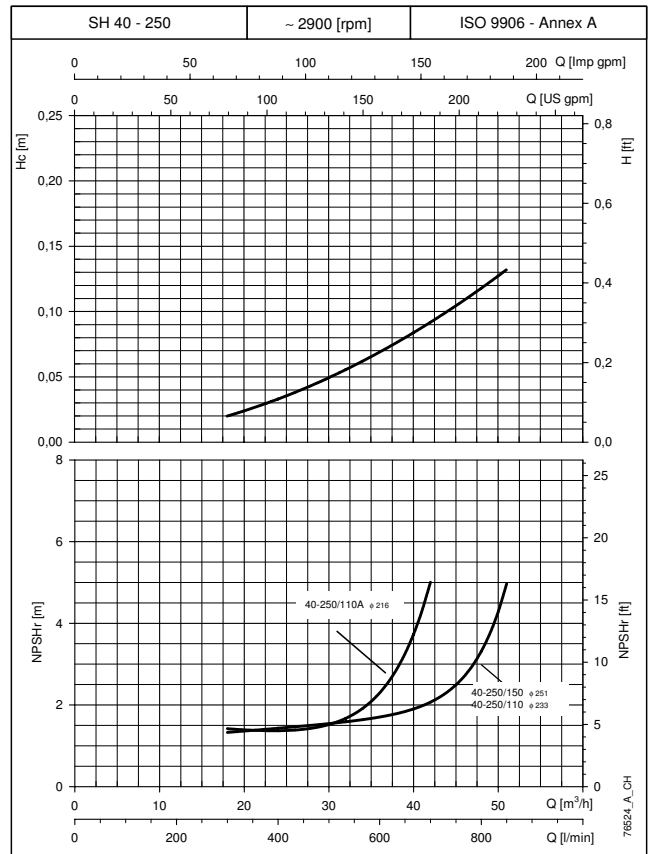
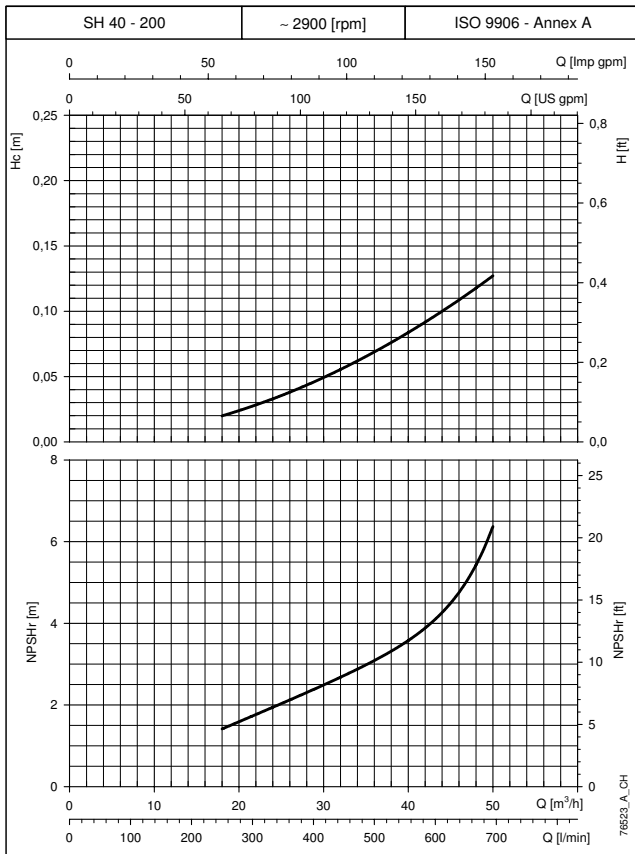
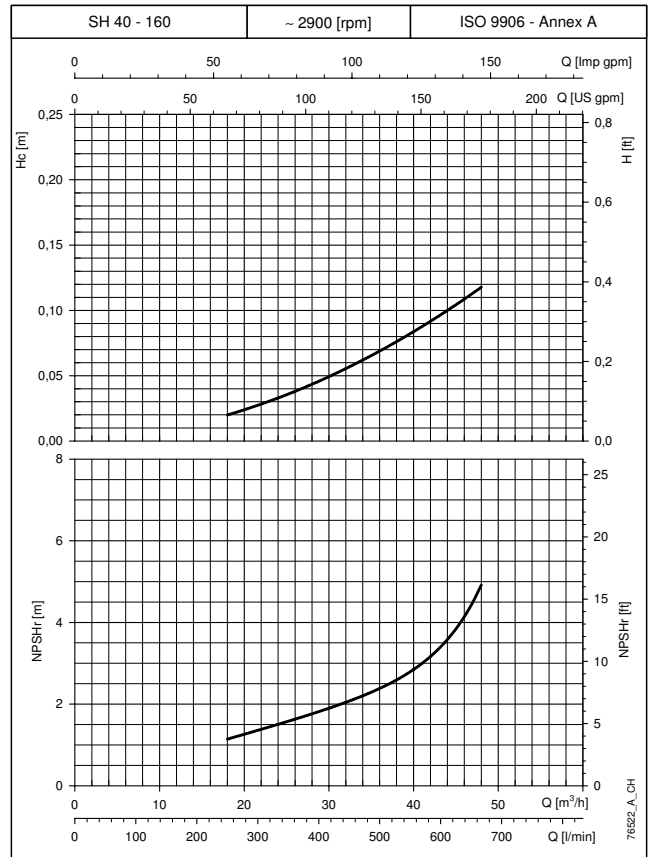
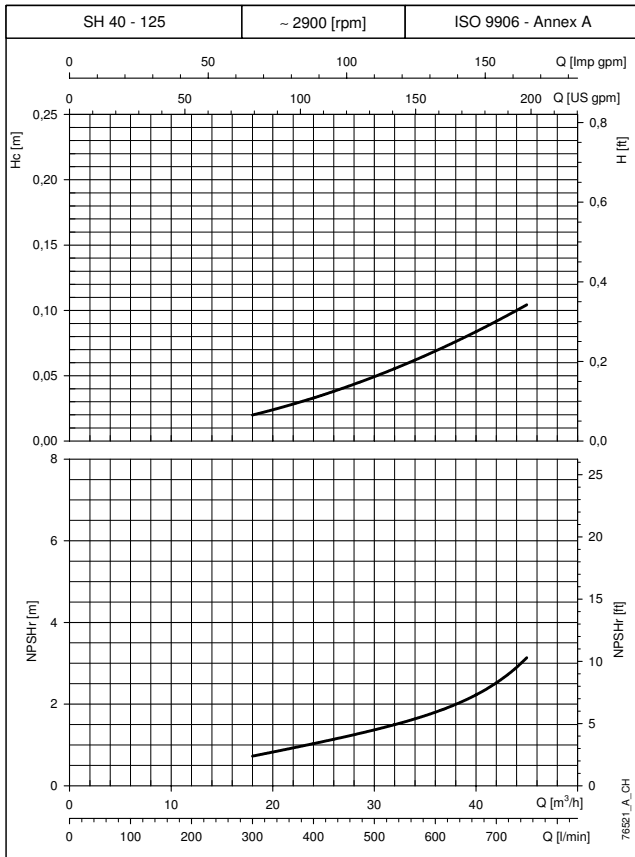

GEN..D/SHF

The declared performance value are valid for liquids with density $\rho = 1.0 \text{ Kg/dm}^3$ and kinematic viscosity $\nu = 1 \text{ mm}^2/\text{sec}$.
The NPSHr values required for the service pump were obtained in the laboratory. When using them for EN 12845 for fire-fighting systems, increase the value by 1 m.
H_c: Pressure drop curve in suction kit.

**GEN..D/SHF SERIES OF BOOSTER SETS (POSITIVE SUCTION HEAD)
H_c PRESSURE DROP CURVE IN SUCTION KIT**

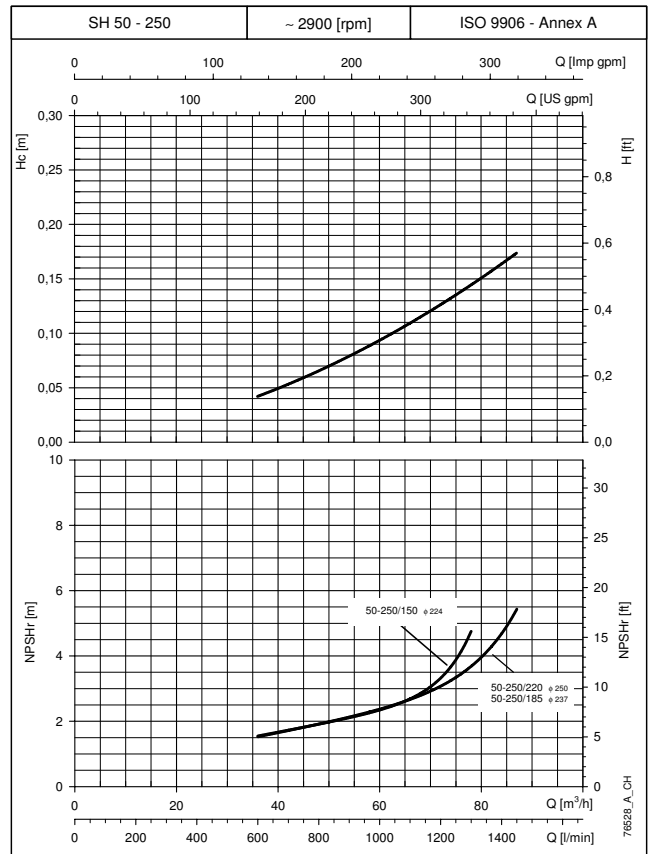
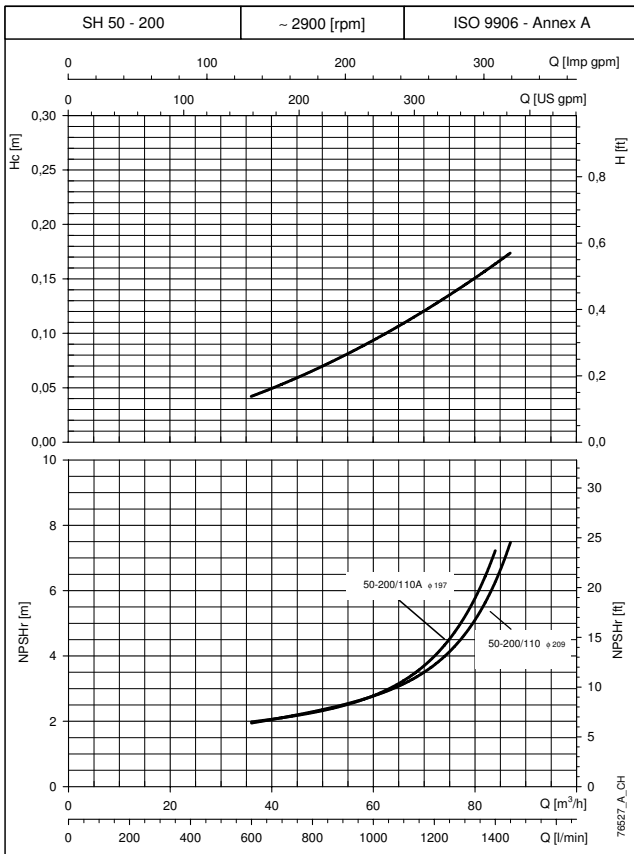
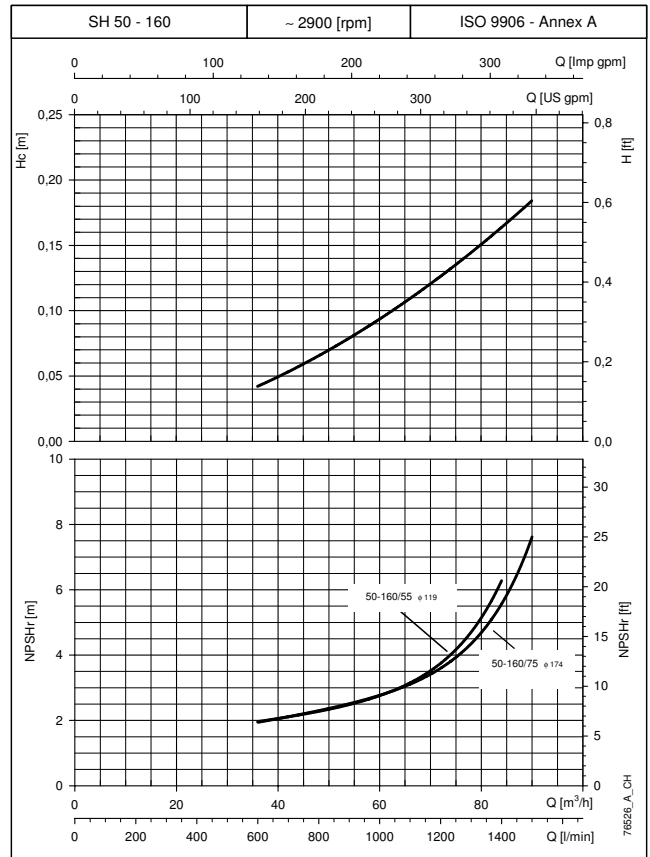
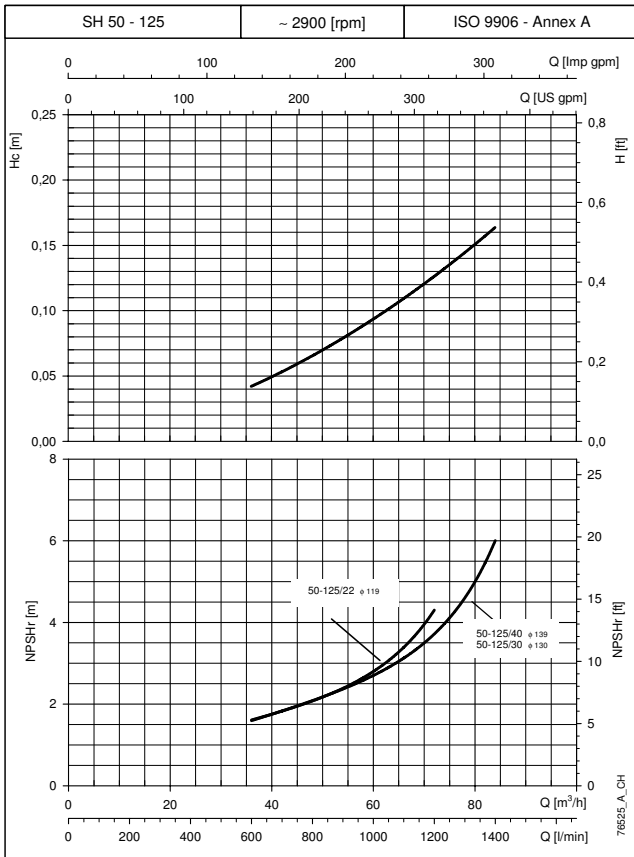

The declared performance value are valid for liquids with density $\rho = 1.0 \text{ Kg/dm}^3$ and kinematic viscosity $\nu = 1 \text{ mm}^2/\text{sec}$.
The NPSHr values required for the service pump were obtained in the laboratory. When using them for EN 12845 for fire-fighting systems, increase the value by 1 m.
H_c: Pressure drop curve in suction kit.

GEN..D/SHF

**GEN..D/SHF SERIES OF BOOSTER SETS (POSITIVE SUCTION HEAD)
H_c PRESSURE DROP CURVE IN SUCTION KIT**

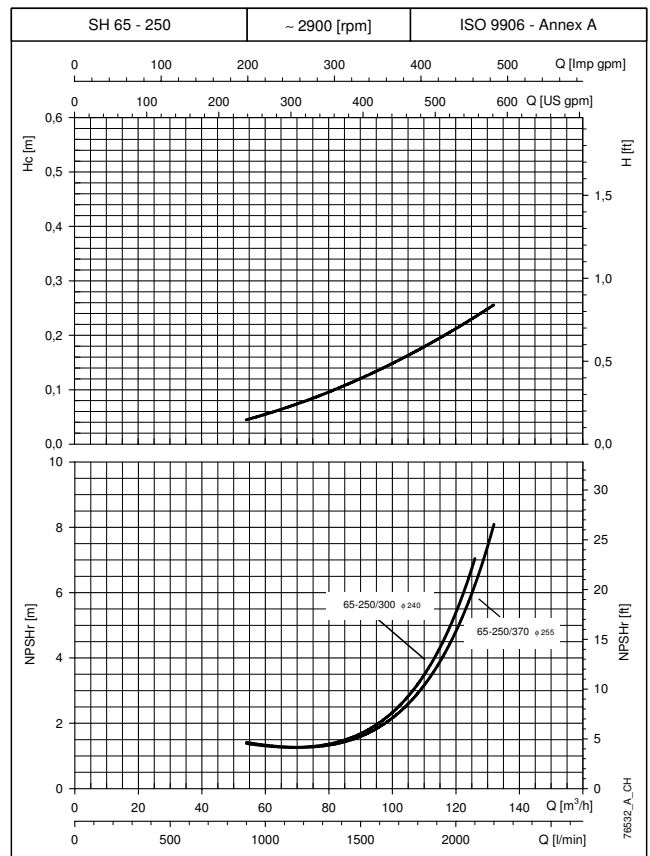
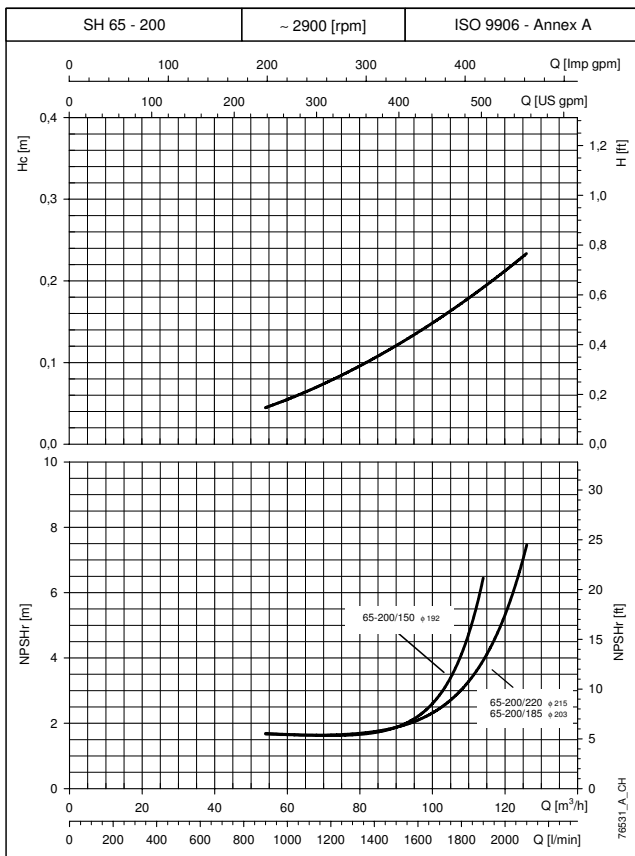
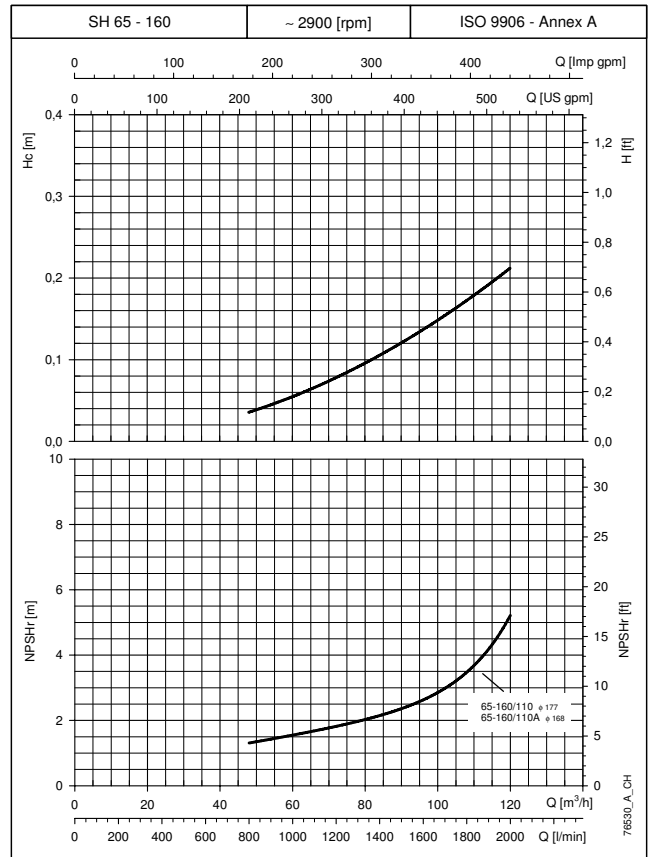
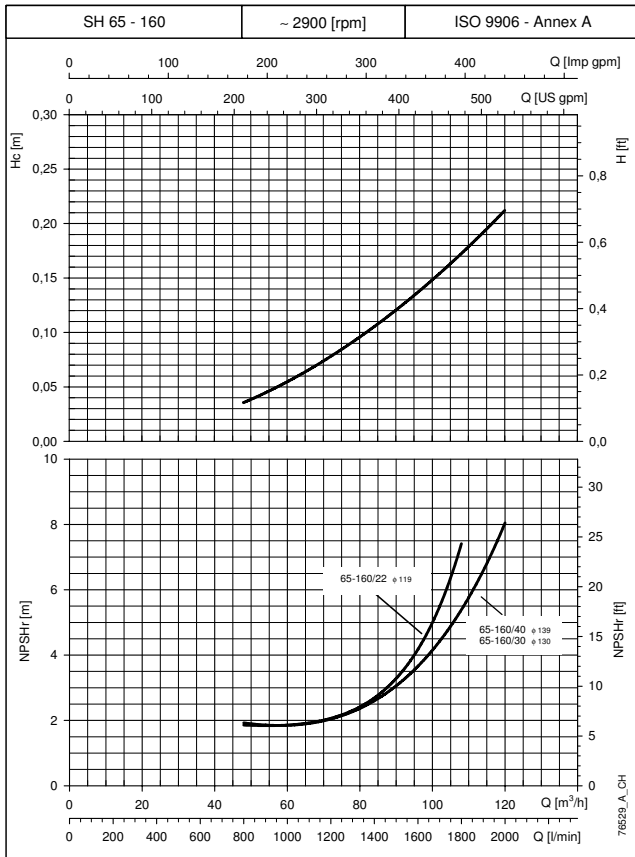

GEN..D/SHF

The declared performance value are valid for liquids with density $\rho = 1.0 \text{ Kg/dm}^3$ and kinematic viscosity $\nu = 1 \text{ mm}^2/\text{sec}$.
The NPSHr values required for the service pump were obtained in the laboratory. When using them for EN 12845 for fire-fighting systems, increase the value by 1 m.
H_c: Pressure drop curve in suction kit.

GEN..D/SHF SERIES OF BOOSTER SETS (POSITIVE SUCTION HEAD) H_c PRESSURE DROP CURVE IN SUCTION KIT

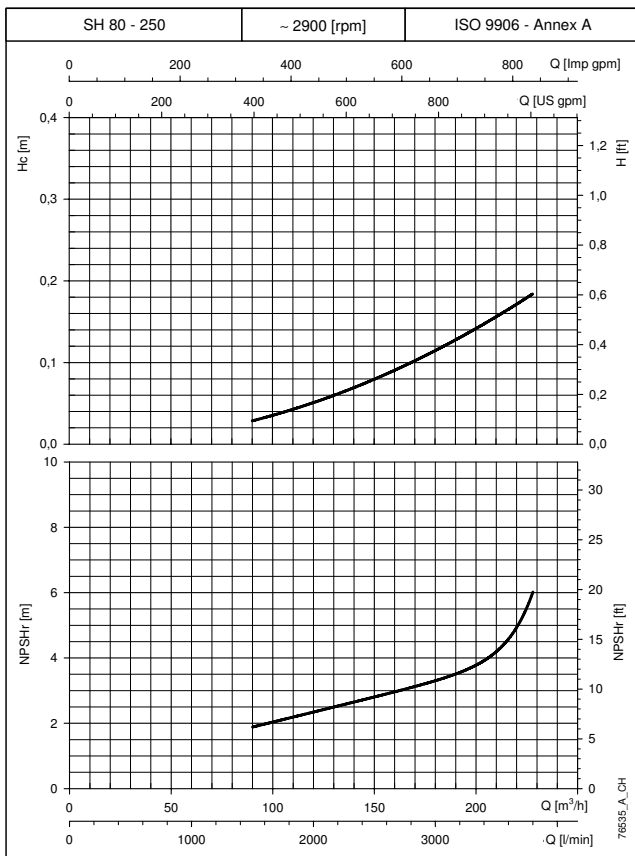
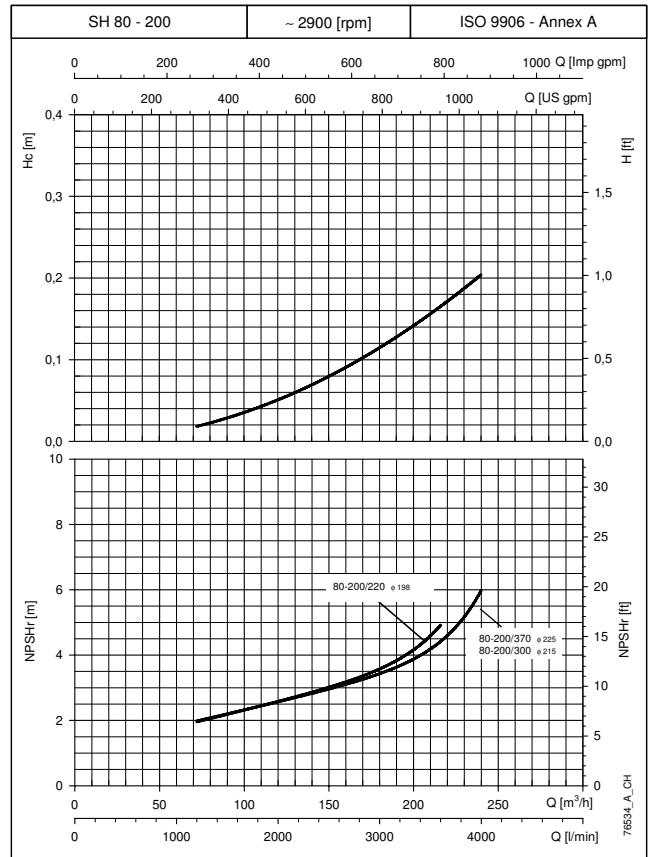
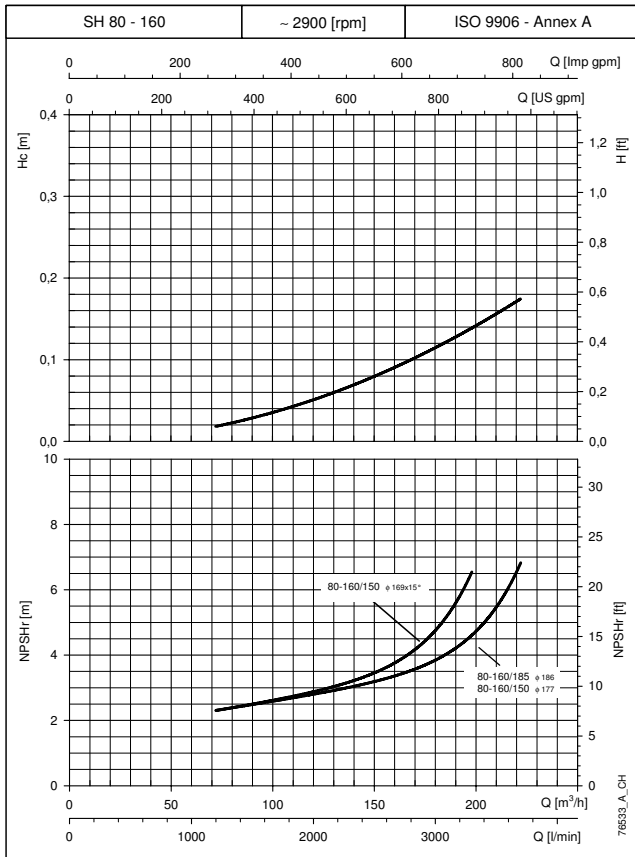

GEN..D/SHF

The declared performance value are valid for liquids with density $\rho = 1.0 \text{ Kg/dm}^3$ and kinematic viscosity $\nu = 1 \text{ mm}^2/\text{sec}$.
 The NPSHr values required for the service pump were obtained in the laboratory. When using them for EN 12845 for fire-fighting systems, increase the value by 1 m.
 H_c: Pressure drop curve in suction kit.

**GEN..D/SHF SERIES OF BOOSTER SETS (SUCTION LIFT)
H_c PRESSURE DROP CURVE IN SUCTION KIT**

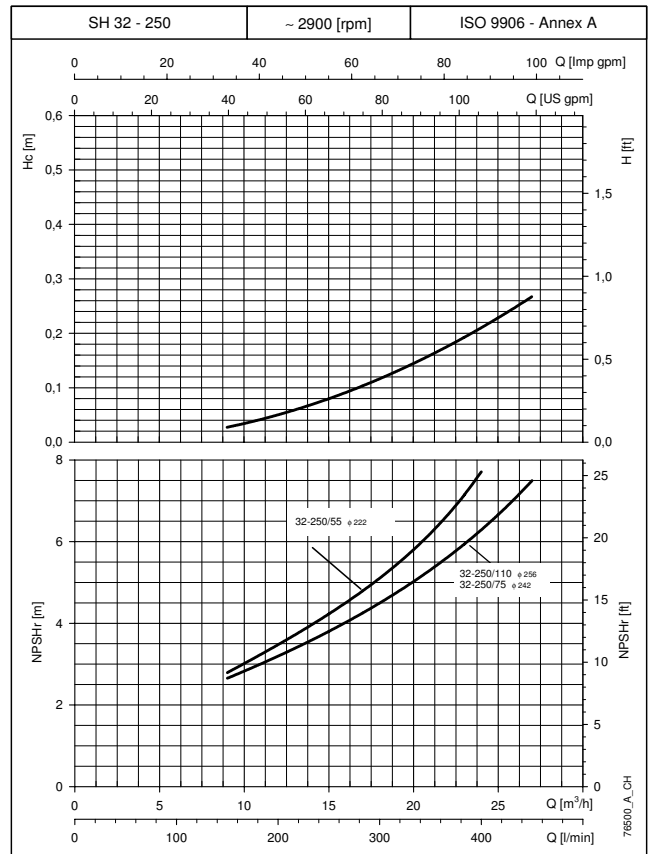
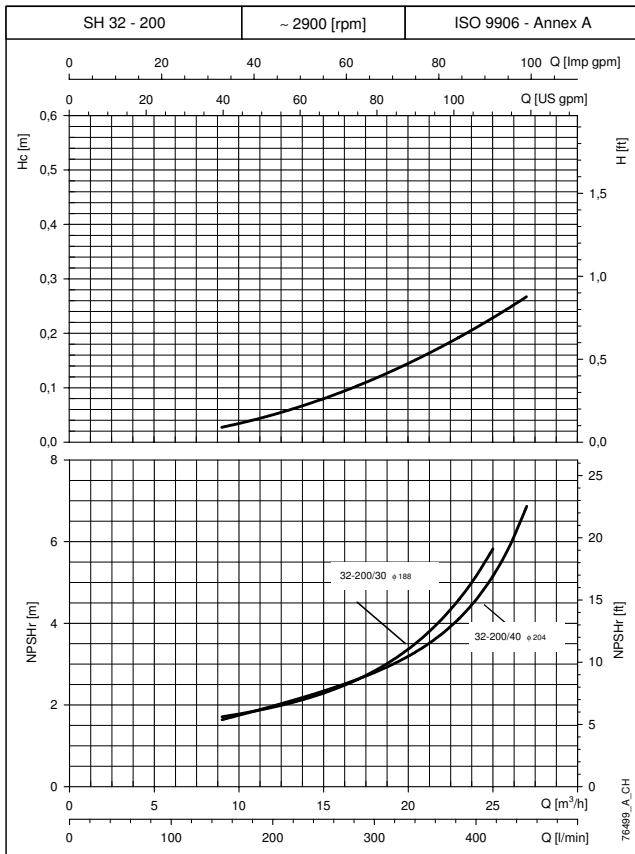
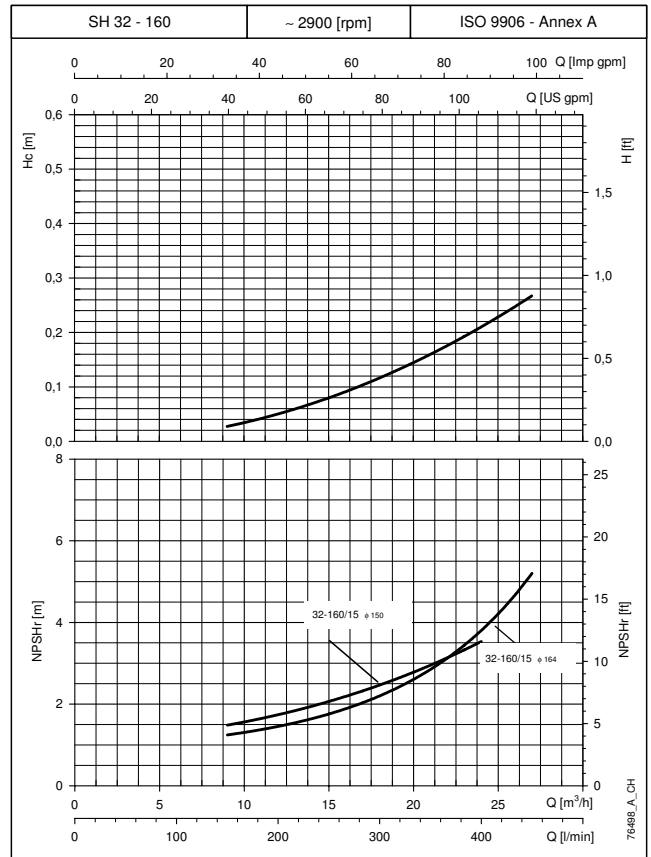
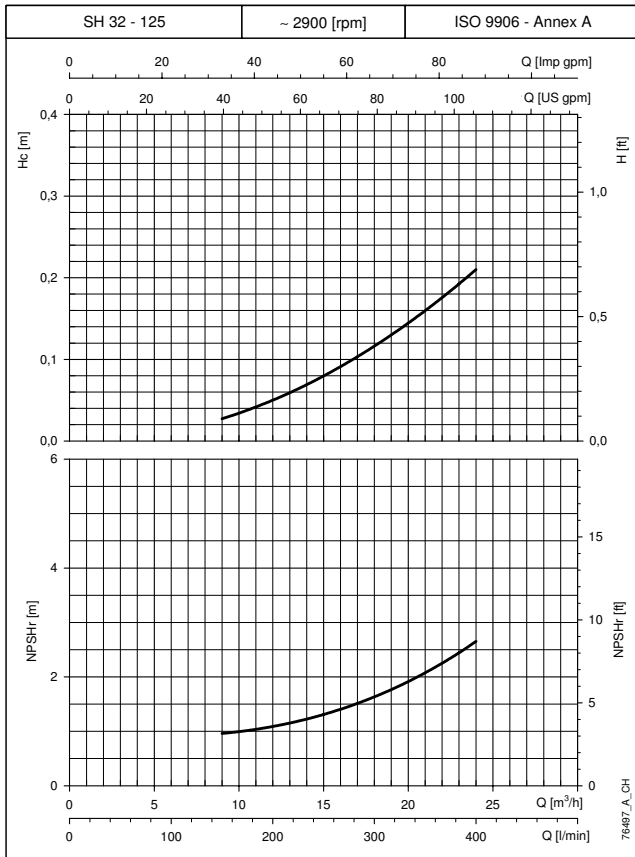

The declared performance value are valid for liquids with density $\rho = 1.0 \text{ Kg/dm}^3$ and kinematic viscosity $\nu = 1 \text{ mm}^2/\text{sec}$.
The NPSHr values required for the service pump were obtained in the laboratory. When using them for EN 12845 for fire-fighting systems, increase the value by 1 m.
H_c: Pressure drop curve in suction kit.

GEN..D/SHF

**GEN..D/SHF SERIES OF BOOSTER SETS (SUCTION LIFT)
H_c PRESSURE DROP CURVE IN SUCTION KIT**

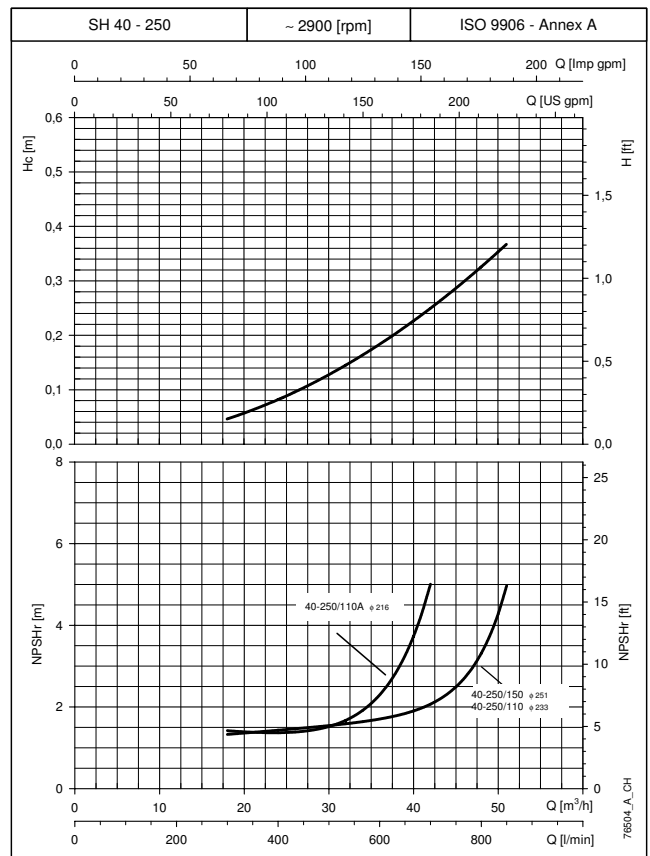
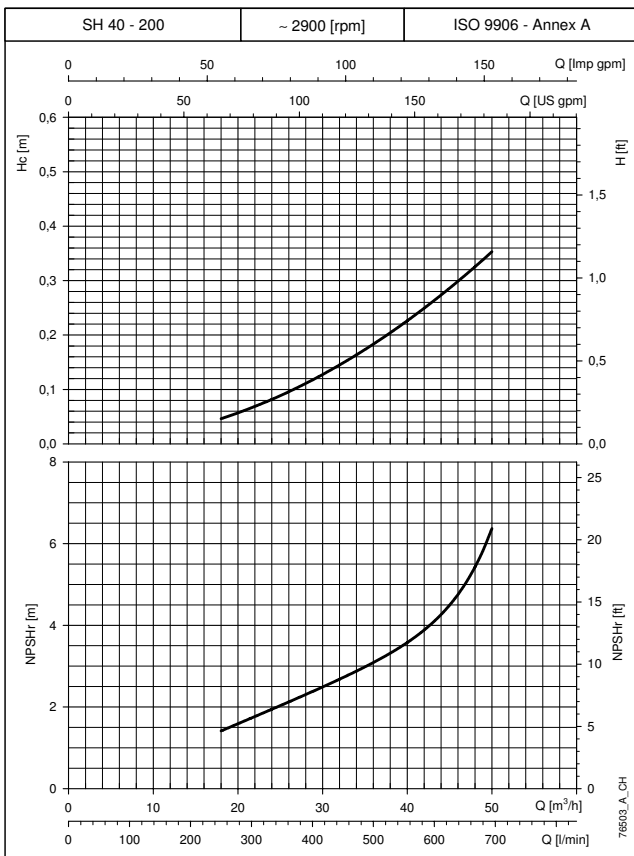
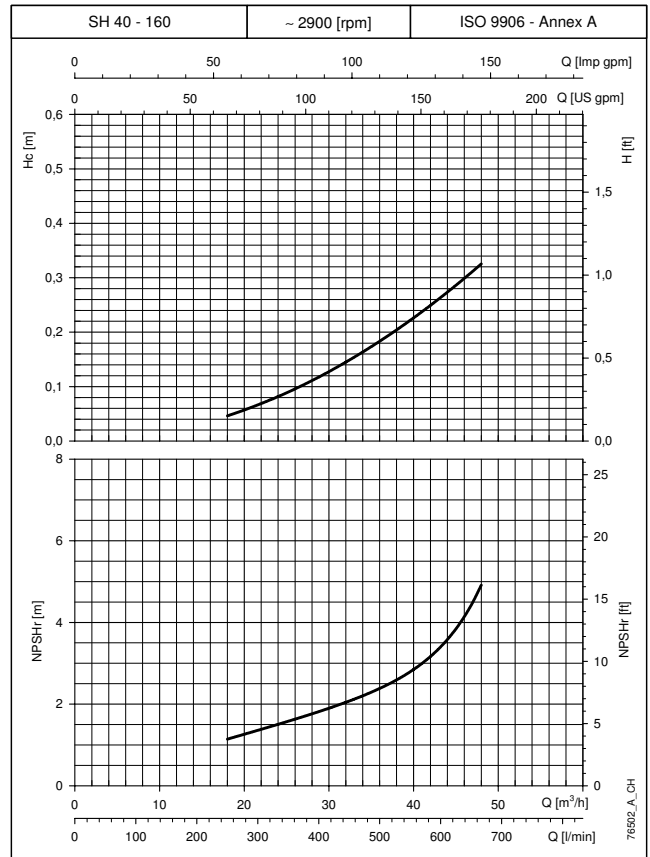
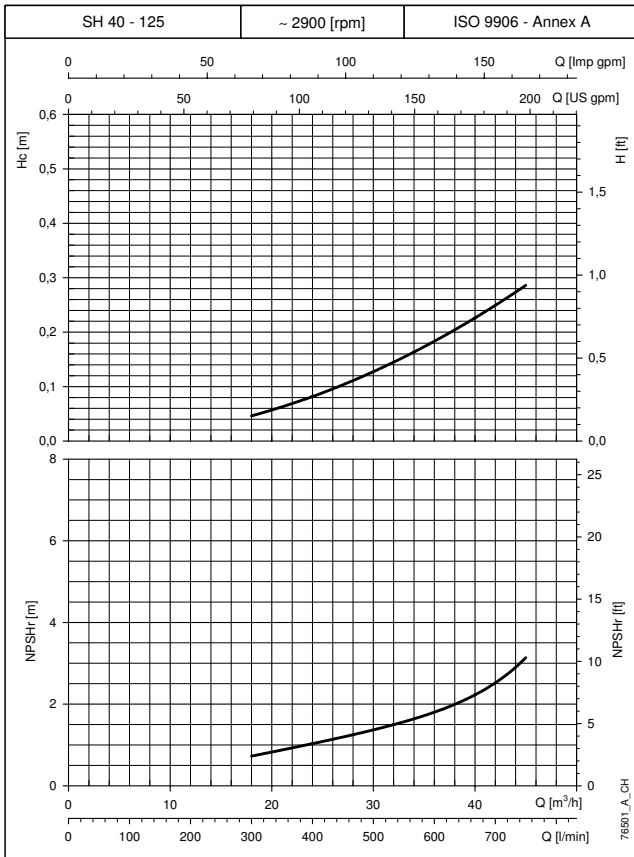

The declared performance value are valid for liquids with density $\rho = 1.0 \text{ Kg/dm}^3$ and kinematic viscosity $\nu = 1 \text{ mm}^2/\text{sec}$.
The NPSHr values required for the service pump were obtained in the laboratory. When using them for EN 12845 for fire-fighting systems, increase the value by 1 m.
H_c: Pressure drop curve in suction kit.

GEN..D/SHF

**GEN..D/SHF SERIES OF BOOSTER SETS (SUCTION LIFT)
H_c PRESSURE DROP CURVE IN SUCTION KIT**

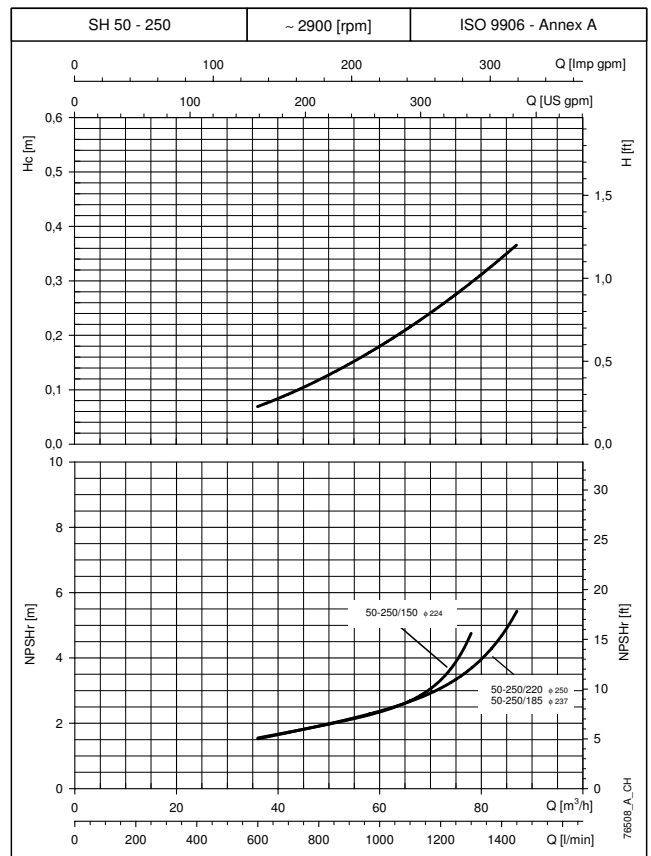
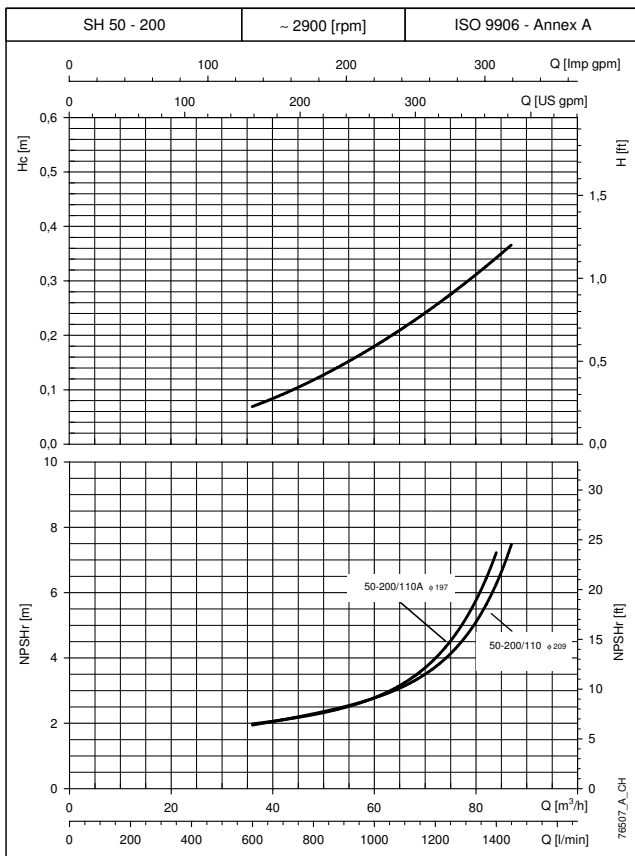
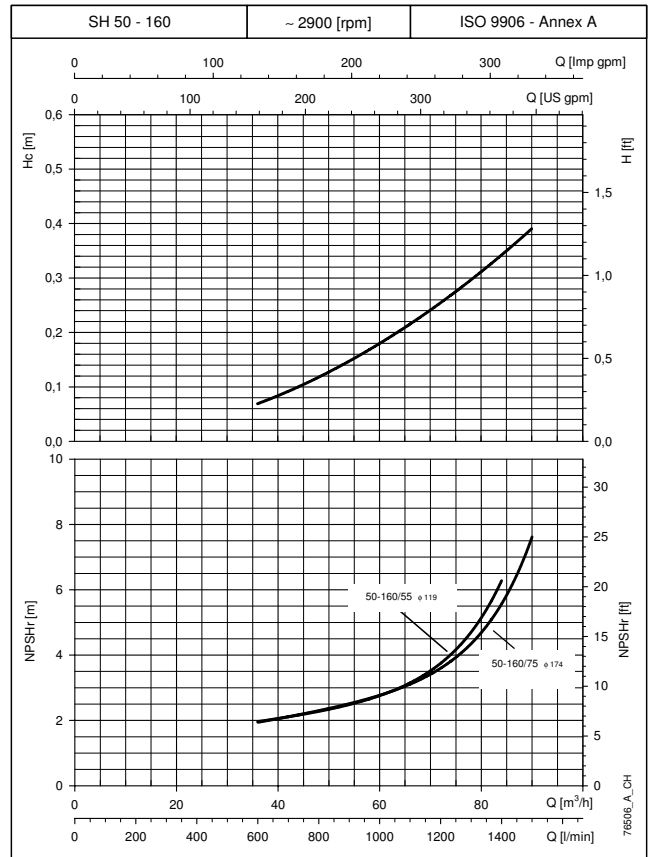
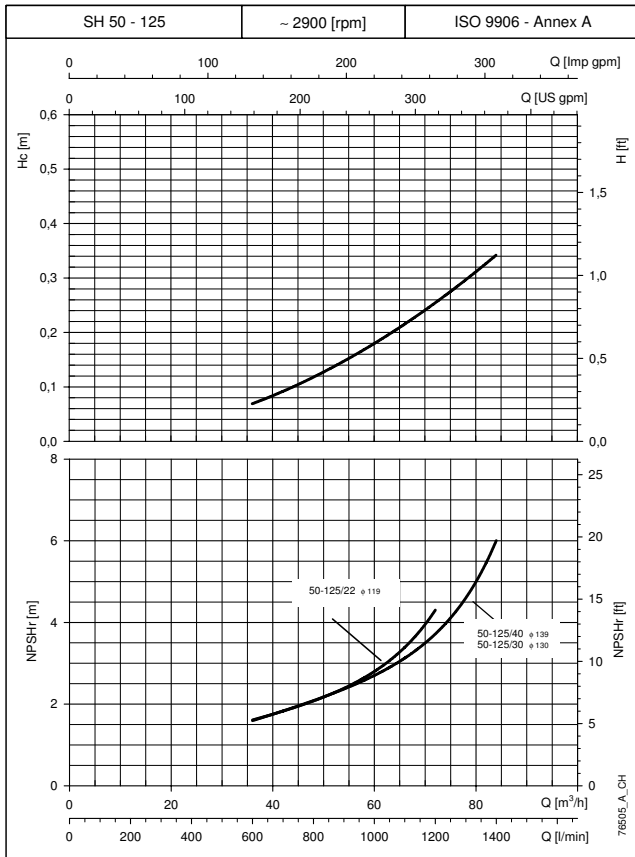

The declared performance value are valid for liquids with density $\rho = 1.0 \text{ Kg/dm}^3$ and kinematic viscosity $\nu = 1 \text{ mm}^2/\text{sec}$.
The NPSHr values required for the service pump were obtained in the laboratory. When using them for EN 12845 for fire-fighting systems, increase the value by 1 m.
H_c: Pressure drop curve in suction kit.

GEN..D/SHF

**GEN..D/SHF SERIES OF BOOSTER SETS (SUCTION LIFT)
H_c PRESSURE DROP CURVE IN SUCTION KIT**

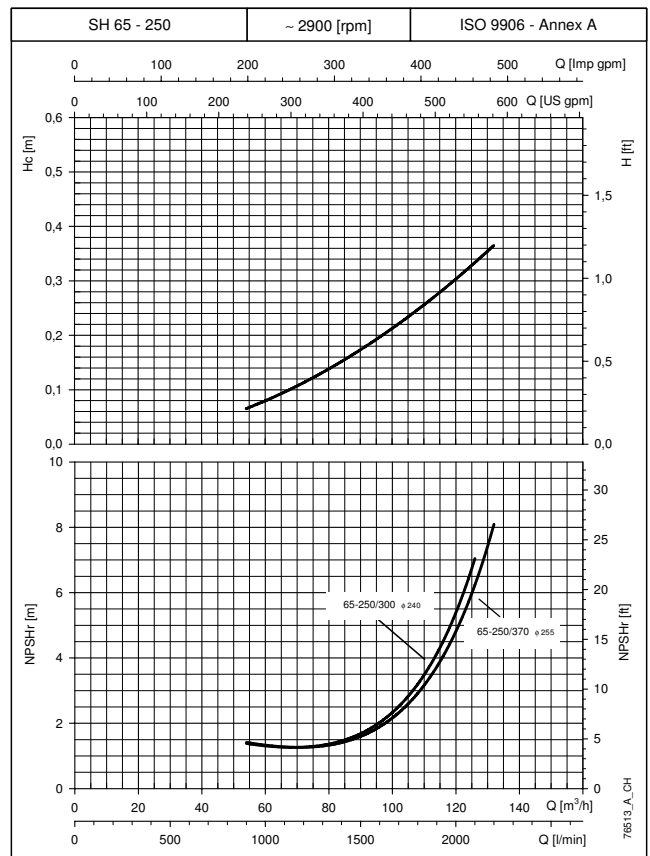
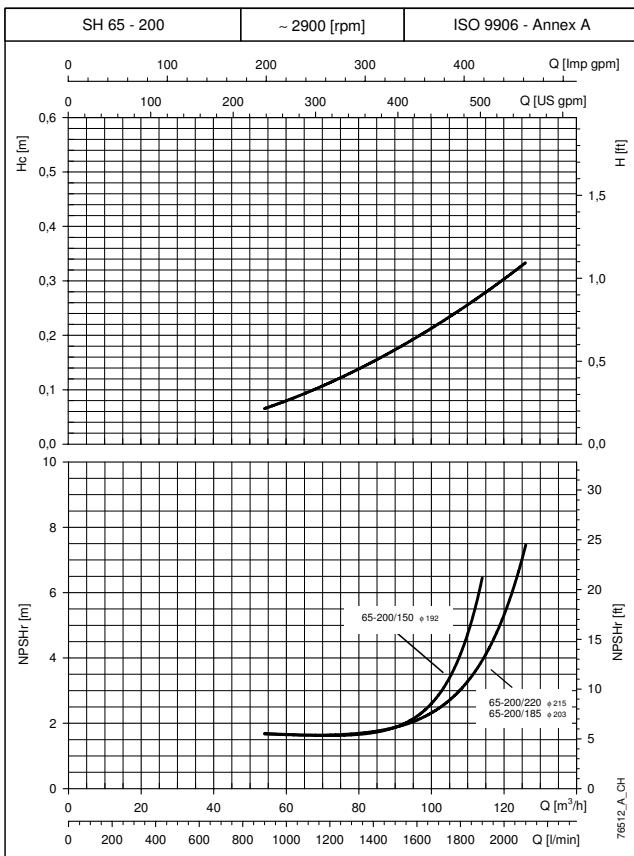
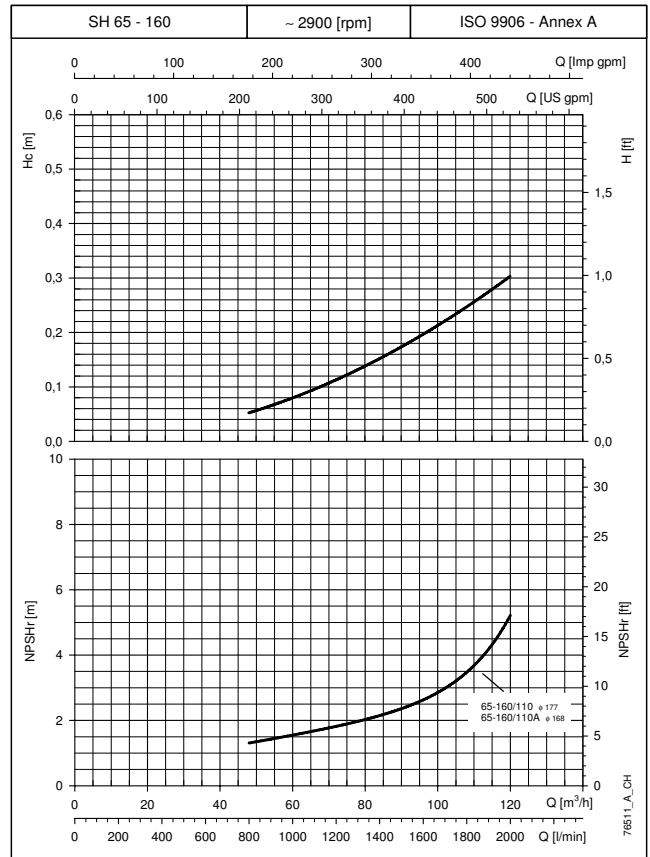
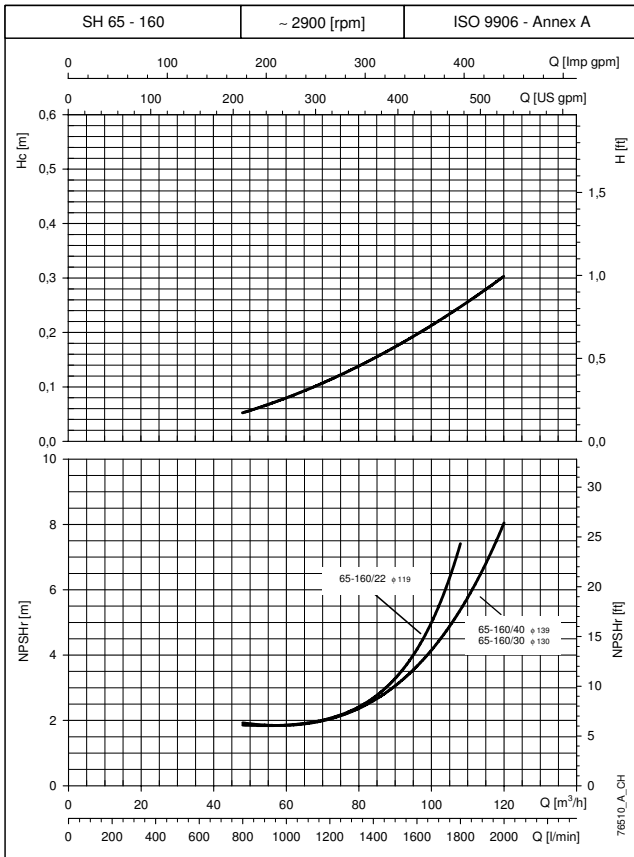

The declared performance value are valid for liquids with density $\rho = 1.0 \text{ Kg/dm}^3$ and kinematic viscosity $\nu = 1 \text{ mm}^2/\text{sec}$.
The NPSHr values required for the service pump were obtained in the laboratory. When using them for EN 12845 for fire-fighting systems, increase the value by 1 m.
H_c: Pressure drop curve in suction kit.

GEN..D/SHF

**GEN..D/SHF SERIES OF BOOSTER SETS (SUCTION LIFT)
H_c PRESSURE DROP CURVE IN SUCTION KIT**

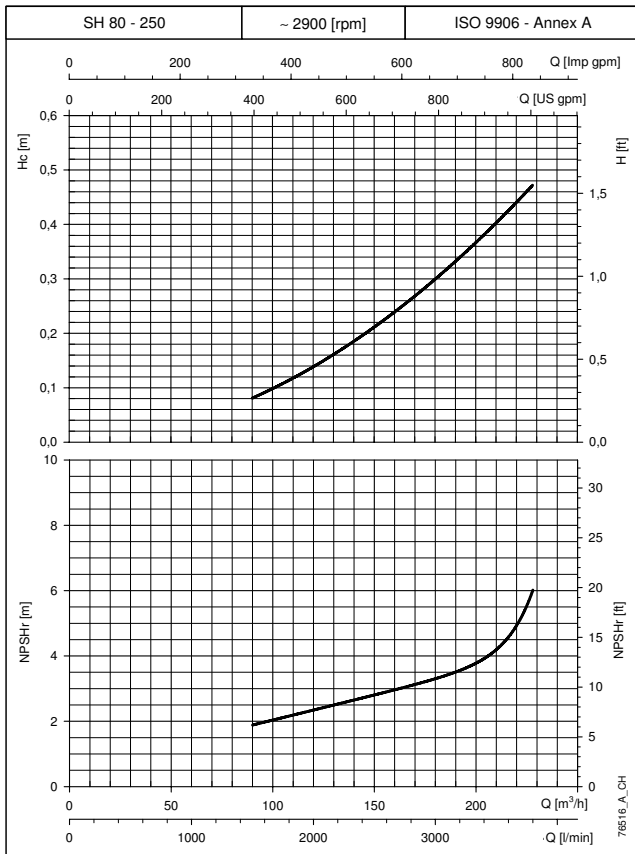
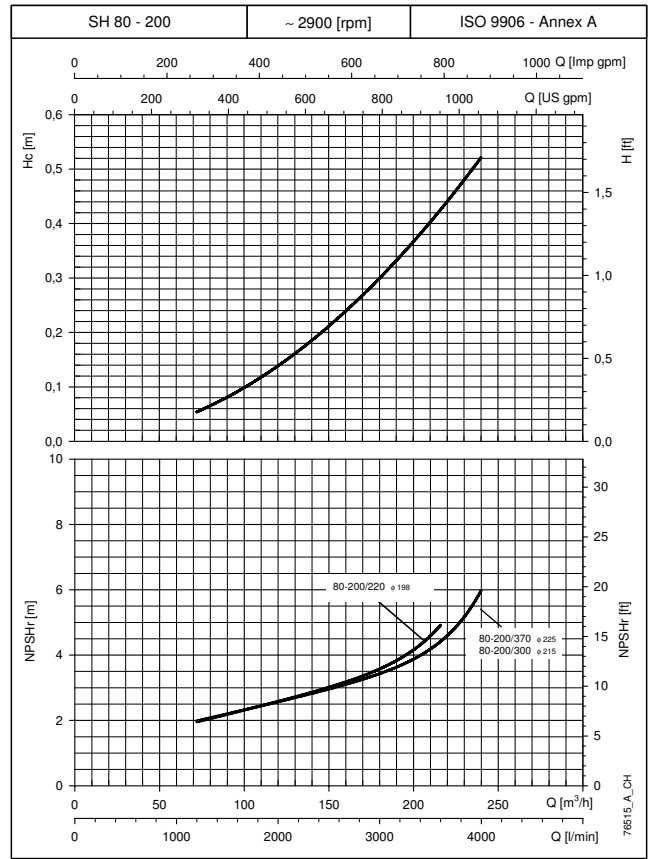
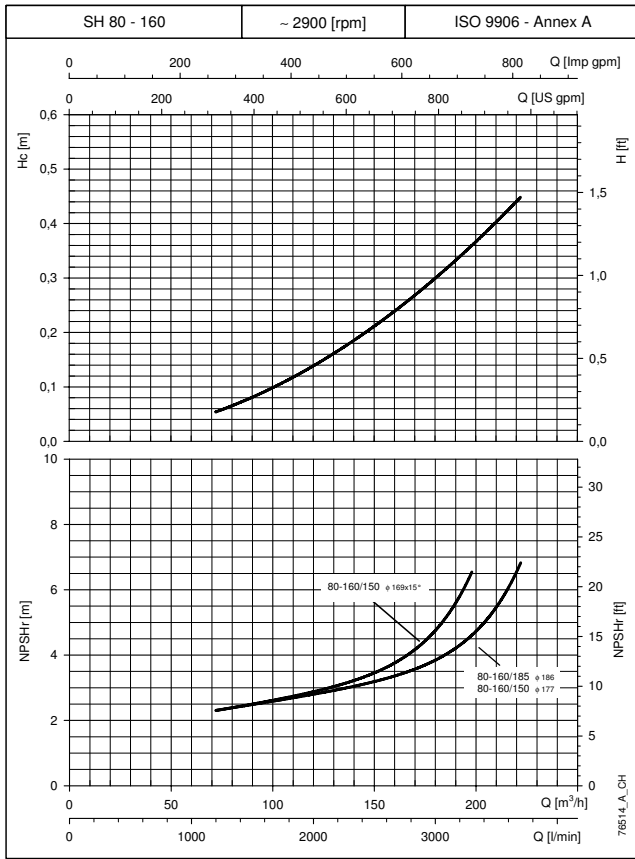

GEN..D/SHF

The declared performance value are valid for liquids with density $\rho = 1.0 \text{ Kg/dm}^3$ and kinematic viscosity $\nu = 1 \text{ mm}^2/\text{sec}$.
The NPSHr values required for the service pump were obtained in the laboratory. When using them for EN 12845 for fire-fighting systems, increase the value by 1 m.
H_c: Pressure drop curve in suction kit.

ACCESSORIES

DIAPHRAGM TANKS

The booster sets are ready for installation, directly on the manifold, of 24-litre diaphragm tanks, one for each pump. The sets are also equipped with caps to close off the unused couplings. Larger tanks can also be connected to the unused end of the discharge manifold. For proper sizing of the tank please refer to the technical appendix.

Kit featuring the following accessories are **available on request**:

- diaphragm tank;
- on-off ball valve;
- operating instructions;
- packaging.

DIAPHRAGM TANK KIT

Volume Litres	PN bar	DIMENSIONS (mm)			Materials		
		ø A	B	Valve	Diaphragm	Vessel	Valve
8	8	205	390	1" FF	EPDM	Painted steel	Nickel-plated brass
24	8	270	555	1" FF	EPDM	Painted steel	Nickel-plated brass
24	10	270	555	1" FF	EPDM	Painted steel	Nickel-plated brass
24	16	270	555	1" FF	EPDM	Painted steel	Nickel-plated brass
24	10	270	575	1" FF	Butyl	Stainless steel	AISI 316 stainless steel
20	25	270	555	1" FF	EPDM	Painted steel	Nickel-plated brass

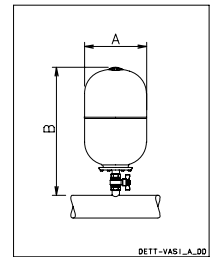

Gcom-vmb-en_c_td

COUNTERFLANGE KIT

Counterflange coupling kits made of zinc-plated or stainless steel are available on request.

The counterflange kits are equipped with:

- N. 2 flanges.
- gasket and bolts/screws.

THREADED COUNTERFLANGES

KIT TYPE	DN	ø C	DIMENSIONS (mm)				HOLES			PN
			ø A	B	ø D	H	ø F	N°		
2"	50	Rp 2	125	16	165	24	18	4	25	
2" 1/2	65	Rp 2 1/2	145	16	185	23	18	4	16	
3"	80	Rp 3	160	17	200	27	18	8	16	

Gcom-ctf-tonde-f-en_a_td

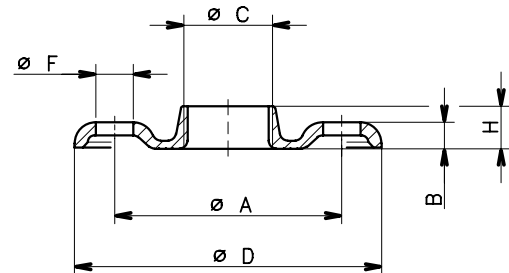

04430_B_DD

WELD-ON COUNTERFLANGES

KIT TYPE	DN	ø C	DIMENSIONS (mm)				HOLES			PN
			ø A	B	ø D	ø F	N°			
2"	50	61	125	19	165	18	4	16		
2 1/2"	65	77	145	20	185	18	4	16		
3"	80	90	160	20	200	18	8	16		
4"	100	116	180	22	220	18	8	16		
5"	125	141,5	210	22	250	18	8	16		
6"	150	170,5	240	24	285	22	8	16		
8"	200	221,5	295	26	340	22	12	16		
10"	250	276,5	355	29	405	26	12	16		
12"	300	327,5	410	32	460	26	12	16		

Gcom-ctf-tonde-s-en_c_td

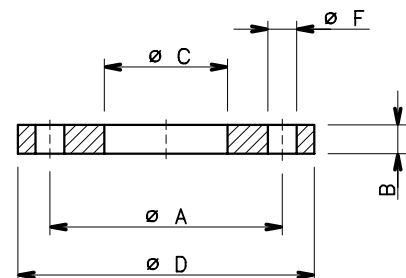

04431_A_DD

ACCESSORIES FOR BOOSTER SETS

SUCTION SIDE KIT

The EN 12845 fire-fighting booster sets are supplied without valves and stubs on the suction side of the service pump and can be completed with suitable kits that depend on legal standards.

These requirements are expressed by EN 12845 (chapter 10.5 and chapter 10.6) and are connected with the maximum speed value of the water in the pipes, their minimum section and type of installation - suction lift or positive suction head.

To provide for one suction kit for each duty pump.

The suction side kit are equipped with:

- Anti-vibration joint to attach to the pump inlet.
- Eccentric cone or flanged stub pipe.
- Vacuum pressure gauge.
- On/off butterfly valve (optional in case of positive suction head installation) with lever handle for diameters up to DN100, butterfly valve with handwheel and reduction manual gear for DN125 and higher. Device for monitoring ON/OFF status included. Electrical connections by customer. (Valve lock kit available on request).
- Weld-on flange.

The following table summarises the pump type installed on the fire-fighting sets and the kit that corresponds to the installation type.

GEN../ SERIES OF FIRE-FIGHTING BOOSTER SETS SUCTION SIDE KIT DIMENSIONS TABLE

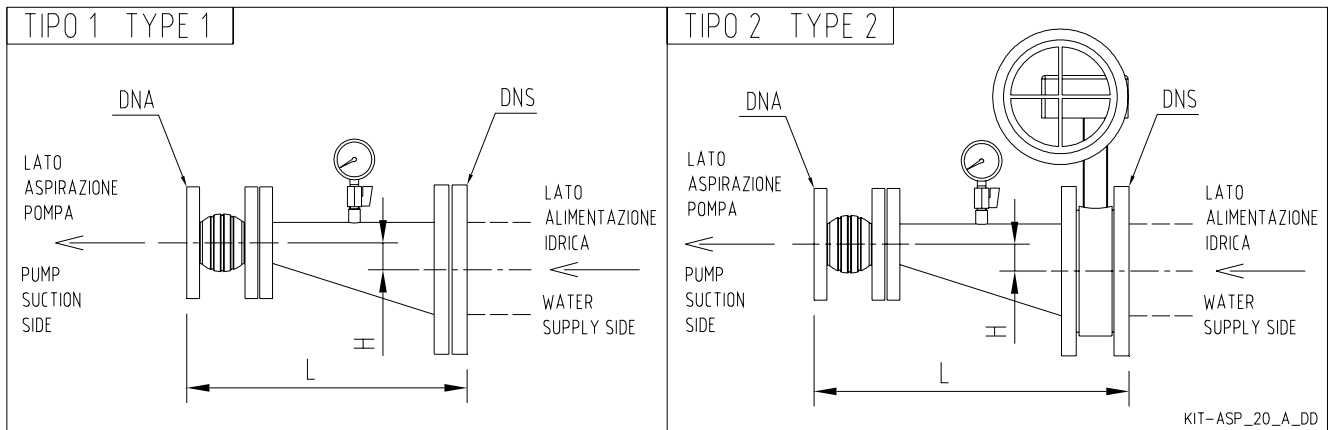

SUCTION KIT TYPE	DIMENSIONS					L (mm)	
	DNS	PN	DNA	PN	H (mm)	Type 1	Type 2
50 X 32	50	16	32	16	9	243	283
50 X 40	50	16	40	16	6	243	283
65 X 32	65	16	32	16	17	269	312
65 X 40	65	16	40	16	14	255	298
65 X 50	65	16	50	16	8	266	309
80 X 32	80	16	32	16	23	304	347
80 X 40	80	16	40	16	20	288	331
80 X 50	80	16	50	16	14	266	309
80 X 65	80	16	65	16	6	277	320
100 X 40	100	16	40	16	33	362	411
100 X 50	100	16	50	16	27	340	389
100 X 65	100	16	65	16	19	307	356
100 X 80	100	16	80	16	13	296	345
125 X 50	125	16	50	16	40	410	463
125 X 65	125	16	65	16	32	377	430
125 X 80	125	16	80	16	25	357	410
125 X 100	125	16	100	16	13	303	356
150 X 65	150	16	65	16	46	460	513
150 X 80	150	16	80	16	40	440	493
150 X 100	150	16	100	16	27	377	430
150 X 125	150	16	125	16	14	355	408
200 X 80	200	10	80	16	65	579	636
200 X 100	200	10	100	16	52	516	573
200 X 125	200	10	125	16	40	482	539
200 X 150	200	10	150	16	25	415	472
250 X 100	250	10	100	16	79	672	737
250 X 125	250	10	125	16	67	637	702
250 X 150	250	10	150	16	52	570	635
300 X 125	300	10	125	16	92	774	849
300 X 150	300	10	150	16	78	707	782
350 X 150	350	10	150	16	94	798	873
400 X 150	400	10	150	16	119	946	1045

Dimensions in mm. Tolerance ± 10 mm.

kit-asp20-en_a_td

GEN../FHF 32-80 SERIES FIRE-FIGHTING BOOSTER SETS SUCTION SIDE KIT DIMENSIONS TABLE

PUMP	SUCTION LIFT				POSITIVE SUCTION HEAD			
	RISK CLASS *	SUCTION KIT TYPE	RISK CLASS *	SUCTION KIT TYPE	RISK CLASS *	SUCTION KIT TYPE	RISK CLASS *	SUCTION KIT TYPE
FHF 32-125/07	LH	65 X 50	-	-	LH	80 X 50	-	-
FHF 32-125/11	LH	65 X 50	-	-	LH	80 X 50	-	-
FHF 32-160/15	LH	65 X 50	-	-	LH	80 X 50	-	-
FHF 32-160/22	LH	65 X 50	-	-	LH	80 X 50	-	-
FHF 32-200/30	LH	65 X 50	-	-	LH	80 X 50	-	-
FHF 32-200/40	LH	65 X 50	-	-	LH	80 X 50	-	-
FHF 40-125/11	OH1	80 X 65	-	-	OH1	100 X 65	-	-
FHF 40-125/15	OH1	80 X 65	-	-	OH1	100 X 65	-	-
FHF 40-125/22	OH1	80 X 65	-	-	OH1	100 X 65	-	-
FHF 40-160/30	OH1	80 X 65	-	-	OH1	100 X 65	-	-
FHF 40-160/40	OH1	80 X 65	-	-	OH1	100 X 65	-	-
FHF 40-200/55	OH1	80 X 65	-	-	OH1	100 X 65	-	-
FHF 40-200/75	OH1	80 X 65	-	-	OH1	100 X 65	-	-
FHF 40-250/110A	OH1	80 X 65	-	-	OH1	100 X 65	-	-
FHF 40-250/110	OH1	80 X 65	-	-	OH1	100 X 65	-	-
FHF 40-250/150	OH1	80 X 65	-	-	OH1	100 X 65	-	-
FHF 50-125/22	OH2	100 X 65	-	-	OH2	125 X 65	-	-
FHF 50-125/30	OH2	100 X 65	-	-	OH2	125 X 65	-	-
FHF 50-125/40	OH3	125 X 65	OH2	100 X 65	OH3	150 X 65	OH2	125 X 65
FHF 50-160/55	OH3	125 X 65	OH2	100 X 65	OH3	150 X 65	OH2	125 X 65
FHF 50-160/75	OH3	125 X 65	OH2	100 X 65	OH3	150 X 65	OH2	125 X 65
FHF 50-200/110A	OH3	125 X 65	OH2	100 X 65	OH3	150 X 65	OH2	125 X 65
FHF 50-200/110	OH3	125 X 65	OH2	100 X 65	OH3	150 X 65	OH2	125 X 65
FHF 50-250/150	OH3	125 X 65	OH2	100 X 65	OH3	150 X 65	OH2	125 X 65
FHF 50-250/185	OH3	125 X 65	OH2	100 X 65	OH3	150 X 65	OH2	125 X 65
FHF 50-250/220	OH3	125 X 65	OH2	100 X 65	OH3	150 X 65	OH2	125 X 65
FHF 65-125/40	OH3	125 X 80	-	-	OH3	150 X 80	-	-
FHF 65-125/55	OH3	125 X 80	-	-	OH3	150 X 80	-	-
FHF 65-125/75	OH3	125 X 80	-	-	OH3	150 X 80	-	-
FHF 65-160/110A	OH4	150 X 80	OH3	125 X 80	OH4	200 X 80	OH3	150 X 80
FHF 65-160/110	OH4	150 X 80	OH3	125 X 80	OH4	200 X 80	OH3	150 X 80
FHF 65-160/150	OH4	150 X 80	OH3	125 X 80	OH4	200 X 80	OH3	150 X 80
FHF 65-200/150	OH4	150 X 80	OH3	125 X 80	OH4	200 X 80	OH3	150 X 80
FHF 65-200/185	OH4	150 X 80	OH3	125 X 80	OH4	200 X 80	OH3	150 X 80
FHF 65-200/220	OH4	150 X 80	OH3	125 X 80	OH4	200 X 80	OH3	150 X 80
FHF 65-250/220	OH4	150 X 80	OH3	125 X 80	OH4	200 X 80	OH3	150 X 80
FHF 65-250/300	OH4	150 X 80	OH3	125 X 80	OH4	200 X 80	OH3	150 X 80
FHF 65-250/370	OH4	150 X 80	OH3	125 X 80	OH4	200 X 80	OH3	150 X 80
FHF 80-160/150	HH1	200 X 100	OH4	150 X 100	HH1	200 X 100	OH4	200 X 100
FHF 80-160/185	HH1	200 X 100	OH4	150 X 100	HH1	200 X 100	OH4	200 X 100
FHF 80-200/220	HH1	200 X 100	OH4	150 X 100	HH1	200 X 100	OH4	200 X 100
FHF 80-200/300	HH1	200 X 100	OH4	150 X 100	HH1	200 X 100	OH4	200 X 100
FHF 80-250/370	HH1	200 X 100	OH4	150 X 100	HH1	200 X 100	OH4	200 X 100
FHF 80-250/450	HH1	200 X 100	OH4	150 X 100	HH1	200 X 100	OH4	200 X 100
FHF 80-250/550	HH1	200 X 100	OH4	150 X 100	HH1	200 X 100	OH4	200 X 100

* For the risk classes refer to para 6, UNI EN12845.

kit-asp-fhf-en_b_td

- the pumps must be chosen according to the performance levels indicated in Tab. 6 para 7.3.1, Tab.7 para 7.3.2 and the classes of risk.
- some pump models can satisfy the conditions of one or more classes of risk.
- always check the correct selection of the pump depending on the performance level of the set.

** Insert the 50 mm minimal thickness under the GEN10 fire-fighting booster sets only.

GEN../FHF 100-125 SERIES FIRE-FIGHTING BOOSTER SETS SUCTION SIDE KIT DIMENSIONS TABLE

PUMP	SUCTION LIFT				POSITIVE SUCTION HEAD			
	RISK CLASS *	SUCTION KIT TYPE	RISK CLASS *	SUCTION KIT TYPE	RISK CLASS *	SUCTION KIT TYPE	RISK CLASS *	SUCTION KIT TYPE
FHF 100-160/185	HH3	250 X 125	HH2	250 X 125	HH3	250 X 125	HH2	250 X 125
FHF 100-160/220	HH4	250 X 125	HH3	250 X 125	HH4	300 X 125**	HH3	250 X 125
FHF 100-160/300	HH4	250 X 125	HH3	250 X 125	HH4	300 X 125**	HH3	250 X 125
FHF 100-200/185	HH3	250 X 125**	HH2	250 X 125**	HH3	250 X 125**	HH2	250 X 125**
FHF 100-200/300	HH3	250 X 125**	HH2	250 X 125**	HH3	250 X 125**	HH2	250 X 125**
FHF 100-200/370	HH4	250 X 125**	HH3	250 X 125**	HH4	300 X 125**	HH3	250 X 125**
FHF 100-200/450	HH4	250 X 125	HH3	250 X 125	HH4	300 X 125**	HH3	250 X 125
FHF 100-250/300	HH3	250 X 125	HH2	250 X 125	HH3	250 X 125	HH2	250 X 125
FHF 100-250/450	HH4	250 X 125	HH3	250 X 125	HH4	300 X 125**	HH3	250 X 125
FHF 100-250/550	HH4	250 X 125	HH3	250 X 125	HH4	300 X 125	HH3	250 X 125
FHF 100-250/750	HH5	300 X 125	HH4	250 X 125	HH5	300 X 125	HH4	300 X 125
FHF 100-250/900	HH6	300 X 125	HH5	300 X 125	HH6	300 X 125	HH5	300 X 125
FHF 125-200/300	HH7	300 X 150	HH6	300 X 150	HH7	300 X 150	HH6	300 X 150
FHF 125-200/450	HH9	300 X 150	HH8	300 X 150	HH9	400 X 150**	HH8	350 X 150**
FHF 125-200/550	HH10	350 X 150**	HH9	300 X 150	HH10	400 X 150**	HH9	400 X 150**
FHF 125-270/750	HH10	350 X 150	HH9	300 X 150	HH10	400 X 150	HH9	400 X 150
FHF 125-270/900	HH10	350 X 150	HH9	300 X 150	HH10	400 X 150	HH9	400 X 150
FHF 125-270/1100	HH10	350 X 150	HH9	300 X 150	HH10	400 X 150	HH9	400 X 150
FHF 125-270/1320	HH10	350 X 150	HH9	300 X 150	HH10	400 X 150	HH9	400 X 150

* For the risk classes refer to para 6, UNI EN12845.

kit-asp-fhf100-en_a_td

- the pumps must be chosen according to the performance levels indicated in Tab. 6 para 7.3.1, Tab. 7 para 7.3.2 and the classes of risk.
- some pump models can satisfy the conditions of one or more classes of risk.
- always check the correct selection of the pump depending on the performance level of the set.

** Insert the 50mm minimal thickness under the GEN10 fire-fighting booster sets only.

GEN../SHF 32-80 SERIES FIRE-FIGHTING BOOSTER SETS SUCTION SIDE KIT DIMENSIONS TABLE

PUMP	SUCTION LIFT				POSITIVE SUCTION HEAD			
	RISK CLASS *	SUCTION KIT TYPE	RISK CLASS *	SUCTION KIT TYPE	RISK CLASS *	SUCTION KIT TYPE	RISK CLASS *	SUCTION KIT TYPE
SHF 32-125/07	LH	65 X 50	-	-	LH	80 X 50	-	-
SHF 32-125/11	LH	65 X 50	-	-	LH	80 X 50	-	-
SHF 32-160/15	LH	65 X 50	-	-	LH	80 X 50	-	-
SHF 32-160/22	LH	65 X 50	-	-	LH	80 X 50	-	-
SHF 32-200/30	LH	65 X 50	-	-	LH	80 X 50	-	-
SHF 32-200/40	LH	65 X 50	-	-	LH	80 X 50	-	-
SHF 32-250/55	LH	65 X 50	-	-	LH	80 X 50	-	-
SHF 32-250/75	LH	65 X 50	-	-	LH	80 X 50	-	-
SHF 32-250/110	LH	65 X 50	-	-	LH	80 X 50	-	-
SHF 40-125/11	OH1	80 X 65	-	-	OH1	100 X 65	-	-
SHF 40-125/15	OH1	80 X 65	-	-	OH1	100 X 65	-	-
SHF 40-125/22	OH1	80 X 65	-	-	OH1	100 X 65	-	-
SHF 40-160/30	OH1	80 X 65	-	-	OH1	100 X 65	-	-
SHF 40-160/40	OH1	80 X 65	-	-	OH1	100 X 65	-	-
SHF 40-200/55	OH1	80 X 65	-	-	OH1	100 X 65	-	-
SHF 40-200/75	OH1	80 X 65	-	-	OH1	100 X 65	-	-
SHF 40-250/110A	OH1	80 X 65	-	-	OH1	100 X 65	-	-
SHF 40-250/110	OH1	80 X 65	-	-	OH1	100 X 65	-	-
SHF 40-250/150	OH1	80 X 65	-	-	OH1	100 X 65	-	-
SHF 50-125/22	OH2	100 X 65	-	-	OH2	125 X 65	-	-
SHF 50-125/30	OH2	100 X 65	-	-	OH2	125 X 65	-	-
SHF 50-125/40	OH3	125 X 65	OH2	100 X 65	OH3	150 X 65	OH2	125 X 65
SHF 50-160/55	OH3	125 X 65	OH2	100 X 65	OH3	150 X 65	OH2	125 X 65
SHF 50-160/75	OH3	125 X 65	OH2	100 X 65	OH3	150 X 65	OH2	125 X 65
SHF 50-200/110A	OH3	125 X 65	OH2	100 X 65	OH3	150 X 65	OH2	125 X 65
SHF 50-200/110	OH3	125 X 65	OH2	100 X 65	OH3	150 X 65	OH2	125 X 65
SHF 50-250/150	OH2	100 X 65	-	-	OH2	125 X 65	-	-
SHF 50-250/185	OH3	125 X 65	OH2	100 X 65	OH3	150 X 65	OH2	125 X 65
SHF 50-250/220	OH3	125 X 65	OH2	100 X 65	OH3	150 X 65	OH2	125 X 65
SHF 65-160/40	OH3	125 X 80	-	-	OH3	150 X 80	-	-
SHF 65-160/55	OH3	125 X 80	-	-	OH3	150 X 80	-	-
SHF 65-160/75	OH3	125 X 80	-	-	OH3	150 X 80	-	-
SHF 65-160/110A	OH3	125 X 80	-	-	OH3	150 X 80	-	-
SHF 65-160/110	OH3	125 X 80	-	-	OH3	150 X 80	-	-
SHF 65-200/150	OH3	125 X 80	-	-	OH3	150 X 80	-	-
SHF 65-200/185	OH3	125 X 80	-	-	OH3	150 X 80	-	-
SHF 65-200/220	OH4	150 X 80	OH3	125 X 80	OH4	200 X 80	OH3	150 X 80
SHF 65-250/300	OH4	150 X 80	OH3	125 X 80	OH4	200 X 80	OH3	150 X 80
SHF 65-250/370	OH4	150 X 80	OH3	125 X 80	OH4	200 X 80	OH3	150 X 80
SHF 80-160/110	HH1	200 X 100	OH4	150 X 100	HH1	200 X 100	OH4	200 X 100
SHF 80-160/150	HH1	200 X 100	OH4	150 X 100	HH1	200 X 100	OH4	200 X 100
SHF 80-160/185	HH1	200 X 100	OH4	150 X 100	HH1	200 X 100	OH4	200 X 100
SHF 80-200/220	HH1	200 X 100	OH4	150 X 100	HH1	200 X 100	OH4	200 X 100
SHF 80-200/300	HH1	200 X 100	OH4	150 X 100	HH1	200 X 100	OH4	200 X 100
SHF 80-200/370	HH1	200 X 100	OH4	150 X 100	HH1	200 X 100	OH4	200 X 100
SHF 80-250/450	HH1	200 X 100	OH4	150 X 100	HH1	200 X 100	OH4	200 X 100
SHF 80-250/550	HH1	200 X 100	OH4	150 X 100	HH1	200 X 100	OH4	200 X 100
SHF 80-250/750	HH1	200 X 100	OH4	150 X 100	HH1	200 X 100	OH4	200 X 100

* For the risk classes refer to para 6, UNI EN12845.

kit-asp-shf-en_a_ld

- the pumps must be chosen according to the performance levels indicated in Tab. 6 para 7.3.1, Tab. 7 para 7.3.2 and the classes of risk.
- some pump models can satisfy the conditions of one or more classes of risk.
- always check the correct selection of the pump depending on the performance level of the set.

** Insert the 50mm minimal thickness under the GEN10 fire-fighting booster sets only.

ALARMS CONTROL ELECTRICAL PANEL

Electric panel for remote status and alarm monitoring of one or two Lowara pumps installed in GEN fire-fighting booster sets, according to EN12845.

In the electric service pump mode, the following conditions are visualised:

- Motor powered.
- Pump start-up request.
- Pump running
- Failure to start.

Additionally: minimum suction tank level, minimum priming tank level, on-off valve on suction and discharge side not fully open. The valves are complete with status monitor.

In the diesel engine service pump mode, the following conditions are visualised, as required by EN12845:

- Switch on diesel engine pump control panel in non-automatic position.
- Diesel engine fails to start after 6 attempts.
- Pump running
- Controller fault.

Additionally: minimum fuel or suction tank level, minimum priming tank level, on-off valve on suction and discharge side not fully open. The valves are complete with status monitor.

All the above conditions, required by EN12845, are visualised with signal LED's and buzzers. A buzzer alarm reset button and LED tester button are included.

The control unit is also fitted out to signal the following general alarms, if present:

- General alarm for incorrect electrical connection in the exchange contacts of: flow meter circuit valve, discharge pump, jockey pump status.
- Fault in electrical connection in the exchange contact relative to panel 1 (electric pump/diesel engine pump)
- Fault in electrical connection in the exchange contact relative to panel 2 (electric pump/diesel engine pump)
- Jockey pump overload (*).
- Jockey pump running(*).
- Discharge pump overload (*).
- Battery voltage low.
- Communications failure with ModBus system.

All the above conditions are visualised with signal LED's and on the display. The customer may decide to enable the buzzer.

The panel comprises a plastic casing (IP55), battery, battery charger, alarms and pump status display, if connected with 485 serial communication.

Fitted to transmit alarms for GSM or PC module.

The electric connection between the contacts on the electric alarms control panel and other electric panels is to be seen to by the person installing the equipment.

(*). Check that the electric control panel combined with the electric pump is complete with clean contacts for pump running and overload signals.

TECHNICAL SPECIFICATIONS

DESCRIPTION	VALUE
Input voltage (single-phase)	(1F+N) 230V +/-10%, 50-60 Hz
Absorbed	0,1A
Dimensions	370 x 275 x 160 mm
Protection grade	IP55
Battery	Hermetic lead
Rated battery voltage	12 Vcc
Rated battery capacity	2,3 Ah (uncharged in 20 h)
Dimensions of battery	178 x 34 x 66 mm
Sound emission levels	75dB
Control panel weight	1,5kg

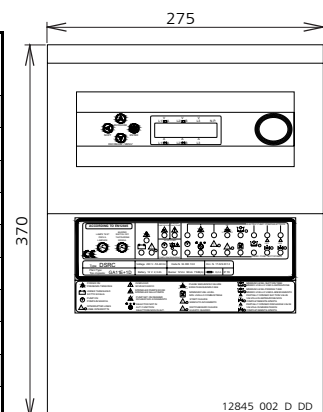

12845-qa-en_b_td

FLOW METER KIT

The flow meter is supplied as part of the assembly kit. The EN 12845 standard requires the presence of the flow meter for checking the hydraulic performance during the test stage and duration periodic inspections. The suction side kit are equipped with:

- Direct reading flow meter.
- On/off ball valve for diameters up to 2" inclusive, butterfly valve with lever handle from DN65 to DN100 diameter, butterfly valve with handwheel and reduction manual gear for DN125 diameter and above. Device for monitoring ON/OFF status included. Electrical connections by customer. (Valve lock kit available on request).
- Connection piping.

The meter is available in various sizes according to the flow of a service pump and suitable for being connected to the offtake of the head manifold. For a correct match, identify the type as shown in the set size tables. The flow meter must be installed, where possible, in a stretch of piping with a steady flow and sufficient back pressure at the discharge outlet. The assembly and the discharge piping towards the tank and discharge outlet are to be seen to by the person installing the equipment.

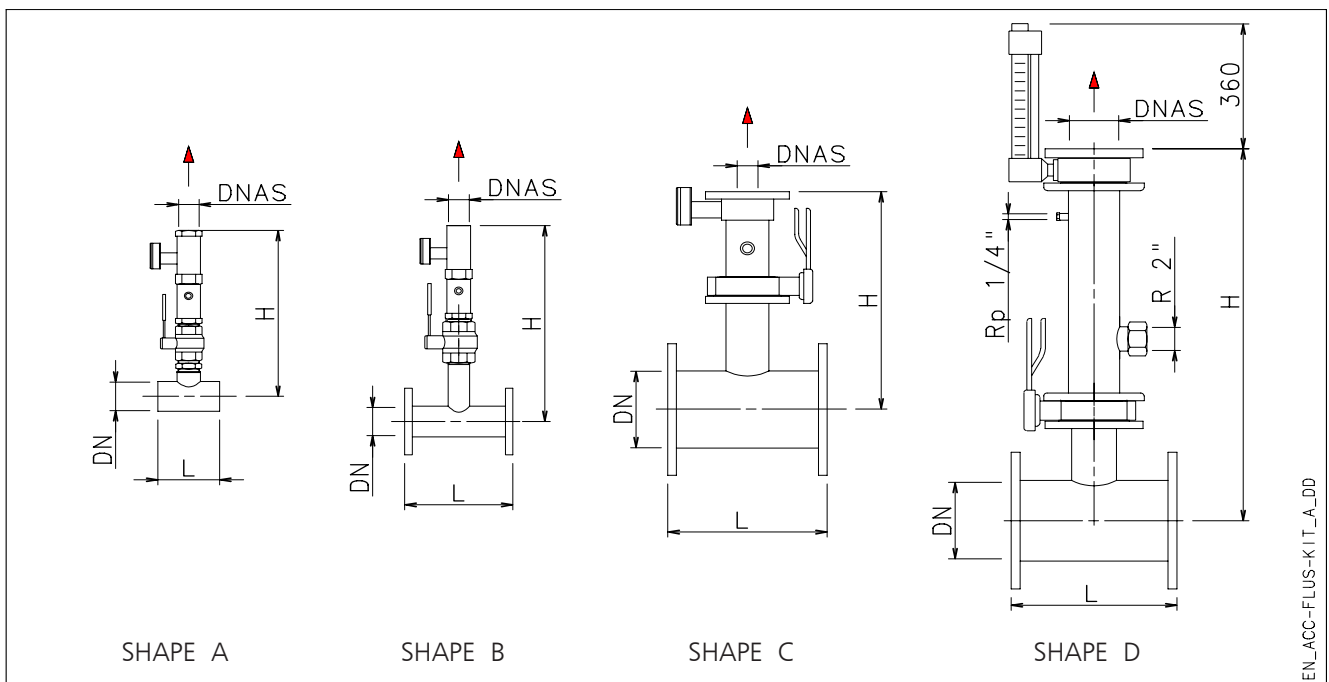

EN_ACC-FLUS-KIT_A_DD

TYPE	DIMENSIONS (mm)					TYPE	DIMENSIONS (mm)				
	DN	DNAS	SHAPE	L	H		DN	DNAS	SHAPE	L	H
32X25P	32	25	A	90	605	100X40P	100	40	B	300	760
32X32P	32	32	A	90	625	100X50P	100	50	B	300	750
32X40P	32	40	A	90	645	100X65P	100	65	C	340	410
40X25P	40	25	A	100	605	100X80P	100	80	C	340	410
40X32P	40	32	A	100	630	100X125	100	125	D	340	945
40X40P	40	40	A	100	645	125X50P	125	50	B	300	760
40X50P	40	50	A	100	640	125X65P	125	65	C	340	425
50X25P	50	25	A	105	610	125X80P	125	80	C	340	425
50X32P	50	32	A	105	635	125X125	125	125	D	340	755
50X40P	50	40	A	105	655	125X150	125	150	D	340	1085
50X50P	50	50	A	105	645	150X65P	150	65	C	380	435
65X25P	65	25	B	300	700	150X80P	150	80	C	380	440
65X32P	65	32	B	300	725	150X125	150	125	D	380	770
65X40P	65	40	B	300	740	150X150	150	150	D	380	900
65X50P	65	50	B	300	730	150X200	150	200	D	380	1380
65X65P	65	65	C	340	390	200X80P	200	80	C	380	465
65X80P	65	80	C	340	595	200X125	200	125	D	380	795
80X40P	80	40	B	300	745	200X150	200	150	D	380	925
80X50P	80	50	B	300	735	200X200	200	200	D	380	1170
80X65P	80	65	C	340	400	250X125	250	125	D	440	825
80X80P	80	80	C	340	400	250X150	250	150	D	440	950
80X125	80	125	D	340	910	250X200	250	200	D	440	1195

12845_kit_flux-acc-en_a_td

TABLE OF COMBINATIONS FOR FLOW METER KIT AND FHF SERVICE PUMP SERIES

TYPE FHF..		COMBINATION FLOW METER KIT				TYPE FHF..		COMBINATION FLOW METER KIT			
ELECTRIC PUMP	PUMP	GEN..				ELECTRIC PUMP	PUMP	GEN..			
		00D	01D	10D	11D			00D	01D	10D	11D
32-125/07	32-125/D119	40X25P	40X25P	50X25P	50X25P	65-200/150	65-200/D187	80X80P	80X80P	100X80P	100X80P
32-125/11	32-125/D136	40X32P	40X32P	50X32P	50X32P	65-200/185	65-200/D198	80X80P	80X80P	100X80P	100X80P
32-160/15	32-160/D150	40X32P	40X32P	50X32P	50X32P	65-200/220	65-200/D210	80X80P	80X80P	100X80P	100X80P
32-160/22	32-160/D164	40X32P	40X32P	50X32P	50X32P	65-250/220	65-250/D220	80X80P	80X80P	100X80P	100X80P
32-200/30	32-200/D188	40X32P	40X32P	50X32P	50X32P	65-250/300	65-250/D241	80X80P	80X80P	100X80P	100X80P
32-200/40	32-200/D204	40X32P	40X32P	50X32P	50X32P	65-250/370	65-250/D258	80X80P	80X80P	100X80P	100X80P
40-125/11	40-125/D112	65X40P	65X40P	65X40P	65X40P	80-160/150	80-160/D163	100X80P	100X80P	125X80P	125X80P
40-125/15	40-125/D122	65X40P	65X40P	65X40P	65X40P	80-160/185	80-160/D173	100X125	100X125	125X125	125X125
40-125/22	40-125/D143	65X50P	65X50P	65X50P	65X50P	80-200/220	80-200/D189	100X80P	100X80P	125X80P	125X80P
40-160/30	40-160/D159	65X40P	65X40P	65X40P	65X40P	80-200/300	80-200/D207	100X125	100X125	125X125	125X125
40-160/40	40-160/D171	65X50P	65X50P	65X50P	65X50P	80-250/370	80-250/D225	100X80P	100X80P	125X80P	125X80P
40-200/55	40-200/D190	65X40P	65X40P	65X40P	65X40P	80-250/450	80-250/D238	100X125	100X125	125X125	125X125
40-200/75	40-200/D209	65X50P	65X50P	65X50P	65X50P	80-250/550	80-250/D256	100X125	100X125	125X125	125X125
40-250/110A	40-250/D218	65X50P	65X50P	65X50P	65X50P	100-160/185	100-160/D150	125X125	125X125	150X125	150X125
40-250/110	40-250/D233	65X50P	65X50P	65X50P	65X50P	100-160/220	100-160/D165	125X125	125X125	150X125	150X125
40-250/150	40-250/D251	65X50P	65X50P	65X50P	65X50P	100-160/300	100-160/D185	125X150	125X150	200X150	200X150
50-125/22	50-125/D119	65X50P	65X50P	80X50P	80X50P	100-200/185	100-200/D168	125X125	125X125	150X125	150X125
50-125/30	50-125/D130	65X65P	65X65P	80X65P	80X65P	100-200/300	100-200/D192	125X125	125X125	150X125	150X125
50-125/40	50-125/D139	65X65P	65X65P	80X65P	80X65P	100-200/370	100-200/D203	125X125	125X125	150X125	150X125
50-160/55	50-160/D158	65X65P	65X65P	80X65P	80X65P	100-200/450	100-200/D213	125X125	125X125	200X125	200X125
50-160/75	50-160/D174	65X65P	65X65P	80X65P	80X65P	100-250/300	100-250/D200	125X125	125X125	150X125	150X125
50-200/110A	50-200/D197	65X65P	65X65P	80X65P	80X65P	100-250/450	100-250/D221	125X125	125X125	200X125	200X125
50-200/110	50-200/D209	65X65P	65X65P	80X65P	80X65P	100-250/550	100-250/D235	125X125	125X125	200X125	200X125
50-250/150	50-250/D224	65X65P	65X65P	80X65P	80X65P	100-250/750	100-250/D254	125X150	125X150	200X150	200X150
50-250/185	50-250/D237	65X65P	65X65P	80X65P	80X65P	100-250/900	100-250/D267	125X150	125X150	200X150	200X150
50-250/220	50-250/D250	65X65P	65X65P	80X65P	80X65P	125-200/300	125-200/D180	150X150	150X150	200X150	200X150
65-125/40	65-125/D121	80X65P	80X65P	100X65P	100X65P	125-200/450	125-200/D206	150X200	150X200	200X200	200X200
65-125/55	65-125/D129	80X65P	80X65P	100X65P	100X65P	125-200/550	125-200/D216	150X200	150X200	200X200	200X200
65-125/75	65-125/D140	80X65P	80X65P	100X65P	100X65P	125-270/750	125-270/D224	150X200	150X200	250X200	250X200
65-160/110A	65-160/D161	80X80P	80X80P	100X80P	100X80P	125-270/900	125-270/D237	150X200	150X200	250X200	250X200
65-160/110	65-160/D168	80X80P	80X80P	100X80P	100X80P	125-270/1100	125-270/D253	150X200	150X200	250X200	250X200
65-160/150	65-160/D178	80X80P	80X80P	100X80P	100X80P	125-270/1320	125-270/D266	150X200	150X200	250X200	250X200

12845_kit_flux-fhf_00D-11D-en_b_th

TABLE OF COMBINATIONS FOR FLOW METER KIT AND SHF SERVICE PUMP SERIES

TYPE SHF..		COMBINATION FLOW METER KIT				TYPE SHF..		COMBINATION FLOW METER KIT			
ELECTRIC PUMP	PUMP	GEN..				ELECTRIC PUMP	PUMP	GEN..			
		00D	01D	10D	11D			00D	01D	10D	11D
32-125/07	32-125/D121	40X32P	40X32P	50X32P	50X32P	50-200/110A	50-200/D197	65X65P	65X65P	80X65P	80X65P
32-125/11	32-125/D136	40X32P	40X32P	50X32P	50X32P	50-200/110	50-200/D209	65X65P	65X65P	80X65P	80X65P
32-160/15	32-160/D150	40X32P	40X32P	50X32P	50X32P	50-250/150	50-250/D224	65X65P	65X65P	80X65P	80X65P
32-160/22	32-160/D168	40X32P	40X32P	50X32P	50X32P	50-250/185	50-250/D237	65X65P	65X65P	80X65P	80X65P
32-200/30	32-200/D188	40X32P	40X32P	50X32P	50X32P	50-250/220	50-250/D250	65X65P	65X65P	80X65P	80X65P
32-200/40	32-200/D204	40X32P	40X32P	50X32P	50X32P	65-160/40	65-160/D119	80X65P	80X65P	100X65P	100X65P
32-250/55	32-250/D222	40X32P	40X32P	50X32P	50X32P	65-160/55	65-160/D129	80X65P	80X65P	100X65P	100X65P
32-250/75	32-250/D242	40X32P	40X32P	50X32P	50X32P	65-160/75	65-160/D137	80X65P	80X65P	100X65P	100X65P
32-250/110	32-250/D256	40X32P	40X32P	50X32P	50X32P	65-160/110A	65-160/D168	80X65P	80X65P	100X65P	100X65P
40-125/11	40-125/D112	65X40P	65X40P	65X40P	65X40P	65-160/110	65-160/D177	80X65P	80X65P	100X65P	100X65P
40-125/15	40-125/D126	65X40P	65X40P	65X40P	65X40P	65-200/150	65-200/D192	80X65P	80X65P	100X65P	100X65P
40-125/22	40-125/D143	65X40P	65X40P	65X40P	65X40P	65-200/185	65-200/D203	80X65P	80X65P	100X65P	100X65P
40-160/30	40-160/D159	65X40P	65X40P	65X40P	65X40P	65-200/220	65-200/D215	80X80P	80X80P	100X80P	100X80P
40-160/40	40-160/D171	65X50P	65X50P	65X50P	65X50P	65-250/300	65-250/D240	80X80P	80X80P	100X80P	100X80P
40-200/55	40-200/D190	65X50P	65X50P	65X50P	65X50P	65-250/370	65-250/D255	80X80P	80X80P	100X80P	100X80P
40-200/75	40-200/D209	65X50P	65X50P	65X50P	65X50P	80-160/110	80-160/D169	100X80P	100X80P	125X80P	125X80P
40-250/110A	40-250/D218	65X40P	65X40P	65X40P	65X40P	80-160/150	80-160/D177	100X80P	100X80P	125X80P	125X80P
40-250/110	40-250/D233	65X40P	65X40P	65X40P	65X40P	80-160/185	80-160/D186	100X125	100X125	125X125	125X125
40-250/150	40-250/D251	65X50P	65X50P	65X50P	65X50P	80-200/220	80-200/D198	100X125	100X125	125X125	125X125
50-125/22	50-125/D119	65X50P	65X50P	80X50P	80X50P	80-200/300	80-200/D215	100X125	100X125	125X125	125X125
50-125/30	50-125/D130	65X65P	65X65P	80X65P	80X65P	80-200/370	80-200/D226	100X125	100X125	125X125	125X125
50-125/40	50-125/D139	65X65P	65X65P	80X65P	80X65P	80-250/450	80-250/D237	100X125	100X125	125X125	125X125
50-160/55	50-160/D158	65X65P	65X65P	80X65P	80X65P	80-250/550	80-250/D252	100X125	100X125	125X125	125X125
50-160/75	50-160/D174	65X65P	65X65P	80X65P	80X65P	80-250/750	80-250/D270	100X125	100X125	125X125	125X125

12845_kit_flux-shf_00D-11D-en_c_th

PRIMING TANK

The priming tank is used in suction lift installations and carries out the function of maintaining the pump body and suction pipe full of water even if there are leaks through the bottom valve.

Each pump must have its own independent priming tank, placed at a higher level than the pump. The tank must be connected to a water source for adding water and keeping it full. The diameter of the connecting pipe to the pump depends on the use class. The return piping for re-circulation can be connected to the tank, which must also provide for discharge if it is too full.

A level indicator automatically actions the service pump if the level of the tank drops and is not reintegrated.

The hydraulic connections must be seen to by the person installing the equipment.

The horizontal 500 l tank is made of zinc-plated steel.

ACCESSORIES PRIMING TANK KIT

The available accessories kit includes:

- Filling and discharge valves, reductions, non-return valve, closing plugs and automatic air discharger.
- Float switch tap complete with ring nut for fixing to the hole through the tank.
- Level indicator to connect to the electric panel and assembly instruction sheet.

Available on request tank support, height 75, 100, 150, 200 cm.

Example of connection to the tank and accessories:

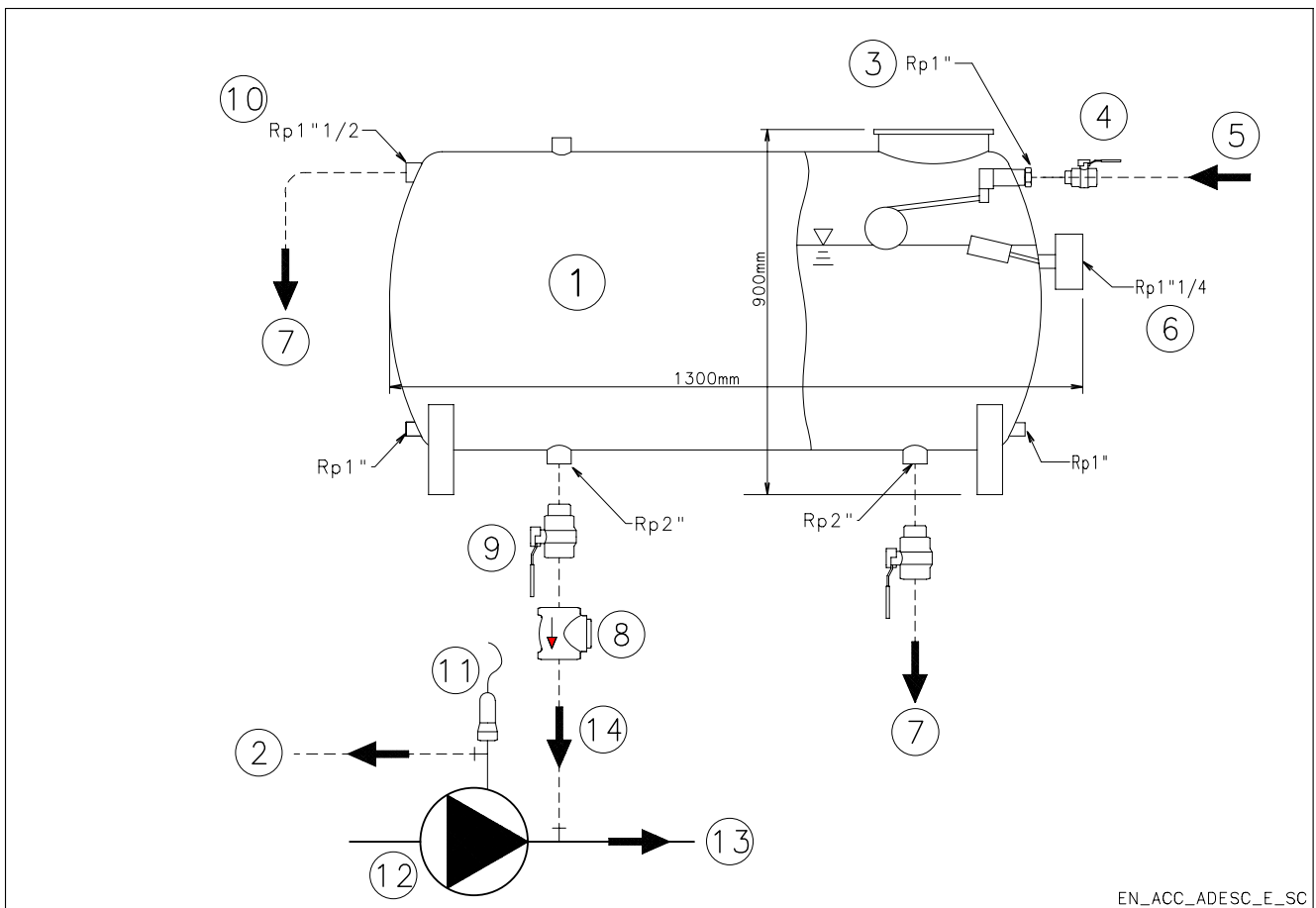

EN_ACC_ADESC_E_SC

N°	DESCRIPTION	N°	DESCRIPTION
1	Pump priming tank	8	Priming supply non return valve
2	Pipe return from pump delivery side	9	Priming supply on-off valve
3	Floating valve	10	Over flow
4	In flow on-off valve	11	Pressure switch
5	In flow	12	Pump
6	Low level switch	13	To trunk main
7	Drain	14	Pipe connection to delivery side of the pump

ELECTRIC JOCKEY PUMP KIT

The jockey pump or compensation pump has the job of keeping the system under pressure and compensating for any small loses without the intervention of the service pumps. In fact, the jockey pump is commanded by an automatic shut-off panel. Should an electric jockey pump of a different size from the standard be required or should it be installed later on sets which are not predisposed, or should non-standard different size requirements be required, it is possible to configure the booster set with just the service pumps and add the electric jockey pump, also later on.

The kit includes:

- the hydraulic components for installing the electric pump (base, valves, pressure switch).
- the pre-chosen electric pump and the relative electric panel.

The hydraulic connection to the set can be easily carried out using one of the couplings on the delivery manifold for the membrane tanks using an adaptor.

Kits are available for the vertical electric jockey pumps 1SV series and submersed series 2GS, 4GS, 6GS.

The diagram illustrates some connection examples:

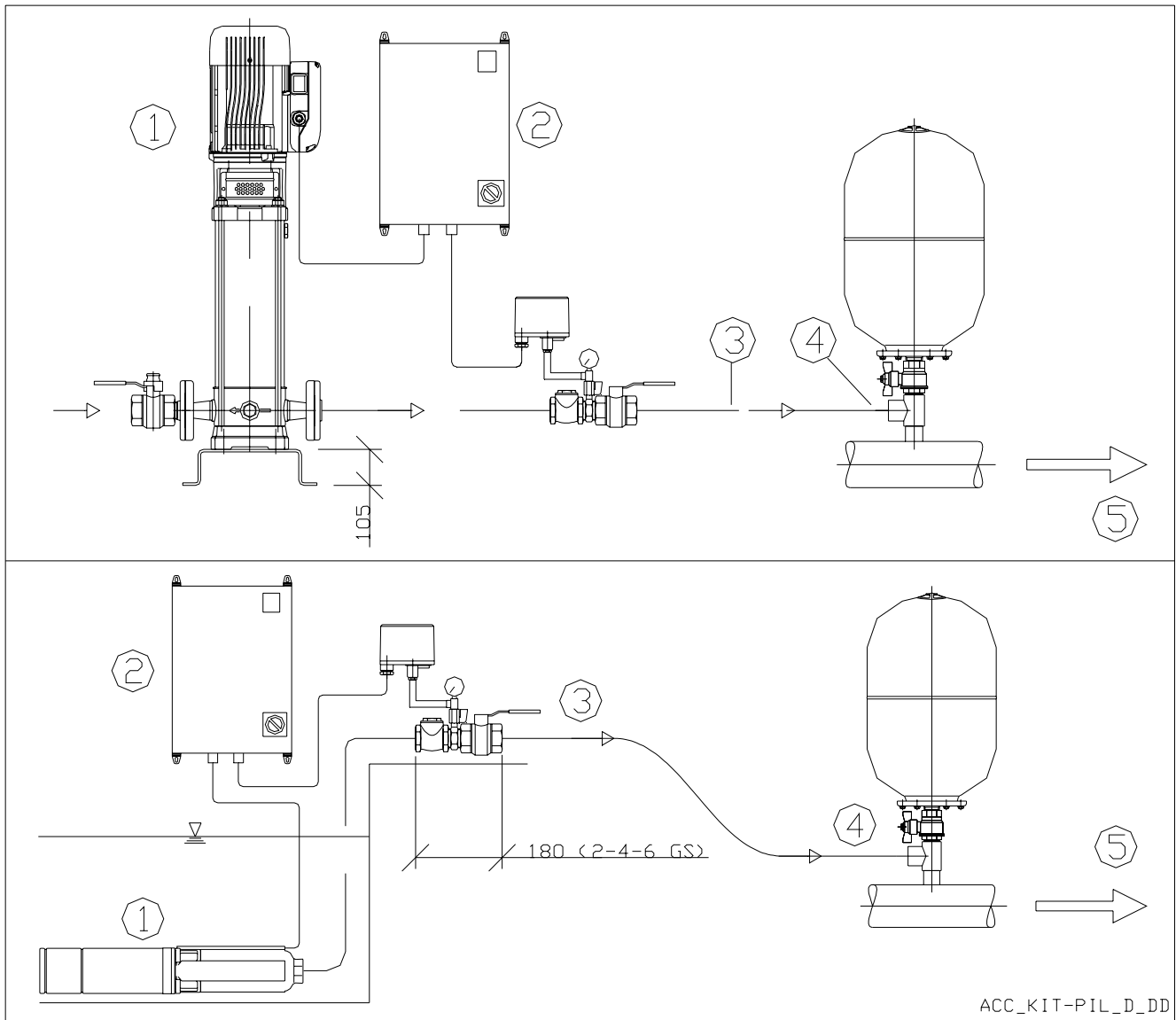

ACC_KIT-PIL_D_DD

ACCESSORIES

N°	DESCRIPTION
1	Electric pump
2	Control Box
3	Connection to trunk main
4	Pipe connection to delivery side of the jockey pump
5	To trunk main

PANEL BRACKET KIT

The electric command panels supplied separately, for example in the sets with submersed pumps, are suitable for being mounted on the wall. Universal bracket kit are available, upon request, for supporting the panels; it must be fixed to the floor using blocks.

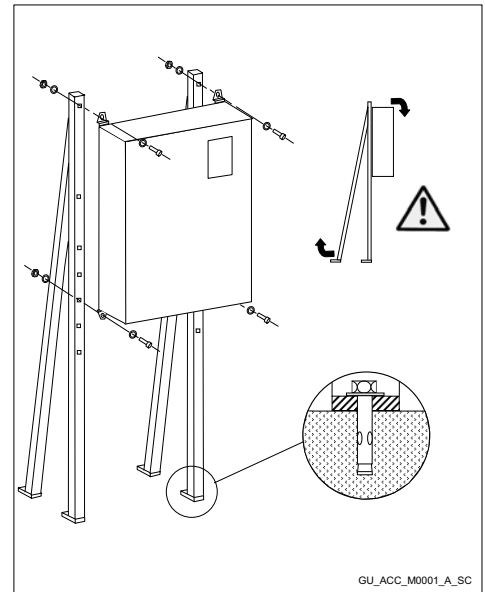

HYDRAULIC CONNECTION FOR FIRE-FIGHTING EN 12845 SETS

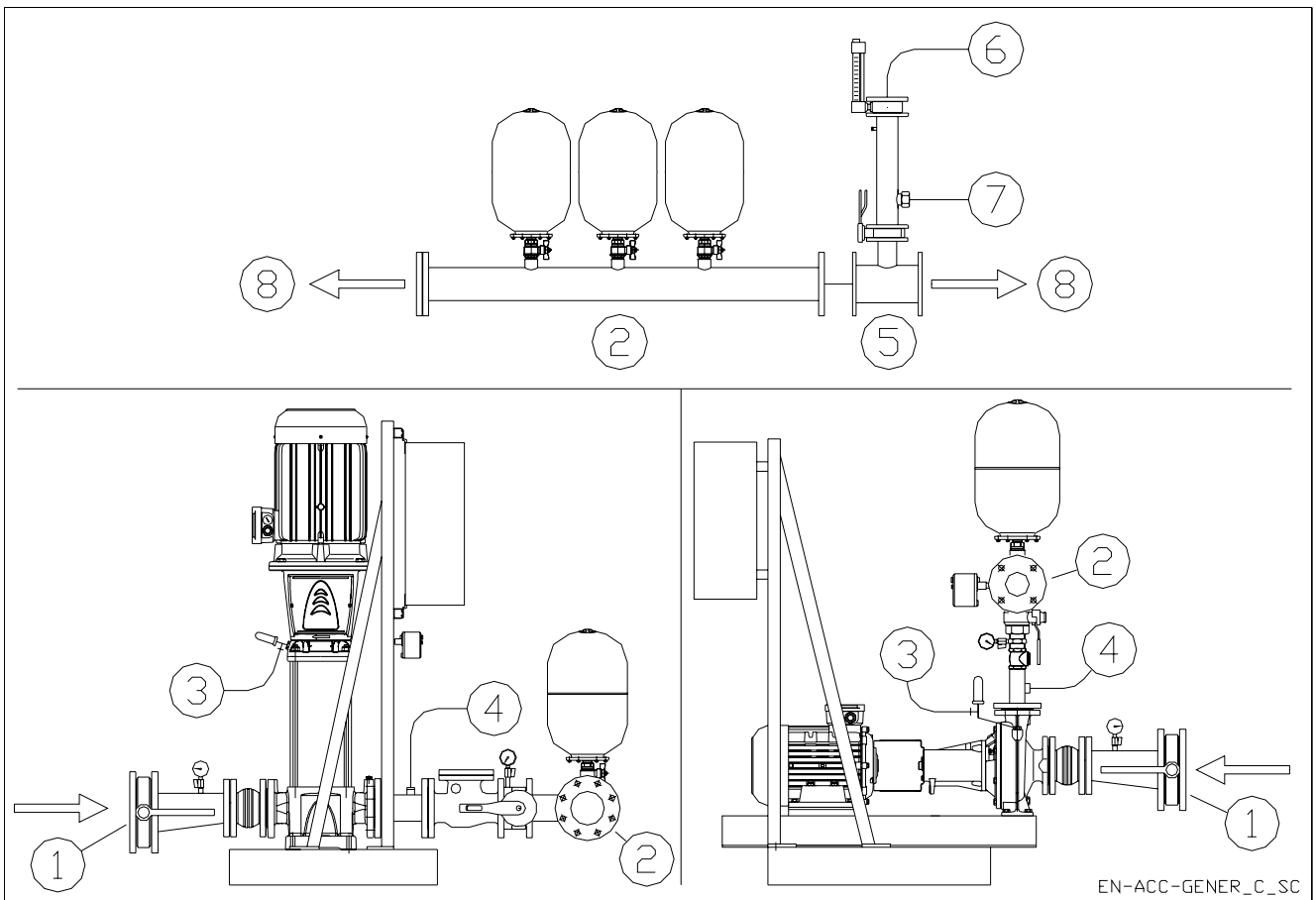

N°	DESCRIPTION	N°	DESCRIPTION
1	Suction piping kit *	5	Flow meter kit *
2	Delivery manifold	6	Drain
3	Drain	7	Open discharge
4	From priming tank *	8	To trunk main

* See the instruction sheets.

ACCESSORIES

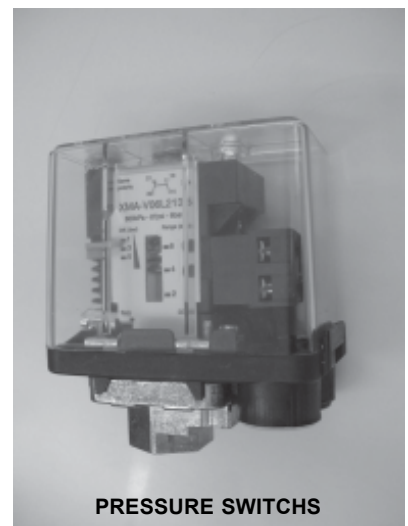
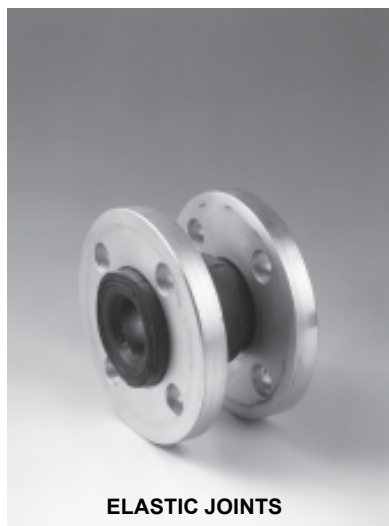
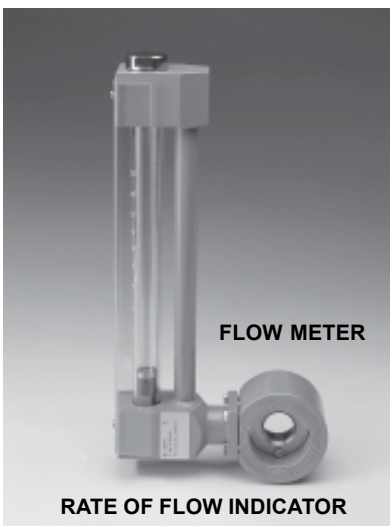
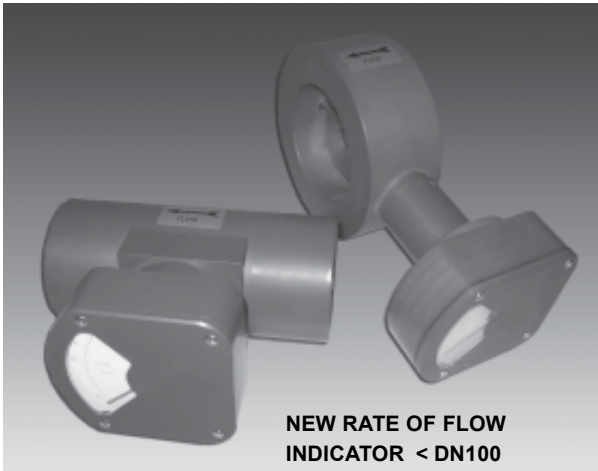

ACCESSORIES

PRODUCT DESCRIPTION BY TECHNICAL SPECIFICATIONS

Description – EN 12845 fire-fighting booster set

Series : GEN

**Model: electric service pump
diesel service pump
jockey or compensation pump**

The pump station will comprise the following components:

- N°1 electric jockey pump;
- N°1 electric service pump;- N°1 backup diesel pump;
- One electrical power and control panel for the electric service pump;
- One electrical power and control panel for the diesel pump;
- One electrical power and control panel for the electric jockey pump;
- Components and materials required for perfect operation and assembly;

Lowara booster sets are CE-certified and comply with the following directives:

- **Machinery Directive 2006/42/EC.**
- **Low Voltage Directive 2006/95/EC.**
- **Electromagnetic Compatibility Directive 2004/108/EC.**
 - **The hydraulic pump complies with the following standard:**
- **ISO 9906-A Rotodynamic pumps – hydraulic performance acceptance tests.**
 - **The fire-fighting booster set complies with European standard EN 12845:
Fixed fire-fighting installations
Automatic sprinkler systems, design, installation and maintenance.**
 - **Version with automatic switch-off according to UNI 10779 “Hydrant systems”
design, installation and operating.**

PRODUCT DESCRIPTION BY TECHNICAL SPECIFICATIONS

Basic version with periodic auto-test, Series GEN..A.

Electronic auto-test circuit with weekly programmer in the electrical panel of the service pump. The pump is turned on and kept working for a minute at the previously established time and date.

During this interval the check circuit checks that the pressure in the re-circulation circuit closes the pressure switch contact of the pump which is running. In the case of irregularities, the relative auxiliary self-test alarm relay available for remote signalling is activated and memorised.

The EN 12845 Standard does not provide for the presence of a self-test circuit but asks for periodic checks to be carried out by the user, hence the periodic self-test function cannot substitute the above checks.

For the precalculated HHP and HHS risk class systems and in the integrally calculated systems, the pump must be able to provide, at 140% of rated capacity, a pressure of not less than 70% of the rated pressure of the pump.

Each pump generally backs up the other even if much depends on the chosen type of water supply. If the service pump fails, or a blackout occurs, system pressure will decrease and the backup diesel pump will start. The pumps are started automatically by the pressure switches while they are manually stopped from the electrical panel (key switch).

➤ **Fire-fighting set components: electric pump**

Electric service pump comprising:

“End-suction” horizontal centrifugal pump, model **FHF**....., single impeller, with cast iron body and AISI316L stainless steel shaft. End suction and radial discharge ports. Impeller in AISI316L stainless steel or cast iron. Hydraulic sizes and nominal diameter DN of suction and discharge ports according to EN 733 (ex DIN 24255).

Flanging to EN 1092-2 (formerly UNI2236) and DIN2532. Maximum running pressure: 12 bar. Mechanical seal according to EN12756 (formerly DIN 24960) in Ceramic/Carbon/NBR lubricated with recirculation duct between discharge and seal housing.

The pump is directly coupled to the respective motor with an elastic spacer joint (“back pull out” version) and alignment and anchor base.

B3 three-phase electric motor with short circuit squirrel cage, totally enclosed, fan-cooled. The performance levels of the electric motors lie within what is usually referred to as efficiency class 1. Protected to IP55, insulation class F.

PRODUCT DESCRIPTION BY TECHNICAL SPECIFICATIONS

Main characteristics of the electric service pump:

Brand	LOWARA		
Model:	FHF		
Flow rate			m ³ /h
Head:			m.c.a.
Pump body:	Cast iron, EN 1561-GJL-200 (JL1030)		
Seal housing:	Cast iron, EN 1561-GJL-200 (JL1030)		
Impeller:	Cast iron, EN 1561-GJL-200 (JL1030)		
Shaft:	Stainless steel EN10088-1-X2 CrNiMo17-12-2		
Elastomers:	NBR		
Mechanical seal:	Ceramic/Carbon/NBR		
Motor power:			Kw
Input voltage:	400 / 3		V
Frequency:	50		Hz
Rated current input:			A
Speed of rotation:	2900		r.p.m.
Max. ambient temp:	40		°C
Protection class:		IP 55	
Insulation class:		F	

tec_FHF-en_b_tm

Backup diesel engine pump comprising:

Normalised horizontal centrifugal pump, **FHF**..... according to EN 733 (ex DIN 24255) – max. operating pressure PN12. End suction and radial discharge ports. Impeller in AISI316L stainless steel or cast iron, mechanical seal in Ceramic/Carbon/NBR lubricated with recirculation duct between the discharge and the seal housing according to EN12756 (formerly DIN 24960).

Main components of the diesel engine pump:

- Electrical panel with battery charger.
- Diesel engine start circuit with two independent batteries.
- Double engine starting relay.
- Engine shut-off device from electric control (Electric stop).
- Fuel tank for diesel engine equipped with float
- Diesel engine coupled to service pump.
- Base made of structural steel with epoxy powder painting RAL 5010.

The diesel pump is supplied on its own base complete with vibration-proof feet, wall-mounted electrical panel fixed to the bracket of the set complete with 3-metre long cable (5 metres available on request) wall- or floor-mounted fuel tank depending on capacity, pair of batteries lying on base with three metres of electrical cable for positioning by the final user near the diesel engine.

PRODUCT DESCRIPTION BY TECHNICAL SPECIFICATIONS

Main characteristics of the diesel engine service pump:

Brand:	LOWARA	
Model:	DFHF	
Flow rate:		m ³ /h
Head:		m.c.a.
Pump body:	Cast iron, EN 1561-GJL-200 (JL1030)	
Seal housing:	Cast iron, EN 1561-GJL-200 (JL1030)	
Impeller:	Cast iron, EN 1561-GJL-200 (JL1030)	
Shaft:	Stainless steel EN10088-1-X2 CrNiMo17-12-2	
Elastomers:	NBR	
Mechanical seal:	Ceramic/Carbon/NBR	
Diesel engine motor power:		Kw
Motor speed:	3000	r.p.m.
Max. ambient temp.:	40	°C
Diesel fuel tank capacity:		l

tec_DFHF-en_b_tm

Electric jockey pump comprising:

Multi-cell vertical centrifugal Jockey pump, **1SV**... with metal parts in contact with liquid in stainless steel, pump body and shaft in AISI 304 stainless steel, impeller in AISI 304 stainless steel, mechanical seal in Carburundum/carbon/EPDM.

Three-phase electric motor, shape B14, performance values within what is referred to as efficiency class 2, short circuit squirrel cage motor, closed aluminium casing and external ventilation, performance according to EN 60034-1, directly coupled to the vertical pump. Protected to IP55, insulation class F.

PRODUCT DESCRIPTION BY TECHNICAL SPECIFICATIONS

Main technical characteristics of the jockey pump:

Brand:	LOWARA	
Model:	1SV	
Flow rate:		m ³ /h
Head:		m.c.a.
Pump body:	Stainless steel (1.4301)	
Impeller:	Stainless steel (1.4301)	
Diffuser:	Stainless steel (1.4301)	
Shaft:	Stainless steel (1.4301)	
Outer sleeve:	Stainless steel (1.4301)	
Mechanical seal:	Silicon carbide/Carbon/EPDM	
Motor power:		Kw
Input voltage:	400 / 3	V
Frequency:	50	Hz
Rated current:		A
Speed:	2900	r.p.m.
Max. ambient temp.:	40	°C
Protection class:	IP - 55	
Insulation class:	F	

tec_SV-en_b_tm

➤ Electric panels

Electric service pump panel

Painted metal casing (IP54) complete with:

- General door-locking switch.
- Analogical ammeter.
- "MAN – AUT – 0" selector with extractable key only in automatic position.
- Keyboard for indicating electric voltage presence, correct phase sequence (three phase power supply), start-up request, pump functioning and no start-up, through LED lamps, lamp test button and starting and stopping buttons, according to the provisions of EN12845 paragraph 10.8.6.

Inside:

- 12/24V transformer for auxiliary circuits and electronic board.
- Fuse holder and fuses for power and auxiliary circuits.

PRODUCT DESCRIPTION BY TECHNICAL SPECIFICATIONS

- Line contact maker (direct start-up), line and star/delta contact makers (star/delta start-up), line contact makers and reactance switching (impedance start-up).
- Star/delta exchanger timer or reactance switching.
- Relay for signalling no phase.
- Auxiliary relays.
- Current transformer.
- Terminal boards.
- Clean contacts (max 24V, 1A) for activating acoustic/ visual alarms for no phase, pump on demand, pump running and start failure.
- Cable glands (excluding the versions to be fixed to the floor).
- Wiring diagram.

Jockey pump electrical panel

Painted metal casing (IP55) complete with:

- General door-locking switch.
- Visual indicators for line, running, thermal shutdown.
- Manual – automatic selector – excluded.

Inside:

- Transformer for auxiliary circuits at 24 V.
- Fuse holder and fuses for power and auxiliary circuits.
- Line contact maker.
- Overload cut-out switch.
- Pump shut-off timer (0 ÷ 90 s).
- Terminal boards.
- Cable glands.
- Wiring diagram.

Suitable for connecting to a float switch or a minimum pressure switch for preventing dry running. An optional level control module (supplied upon request) allows the connection of probes with the possibility of regulating the sensitivity according to the hardness of the water.

Control panel for diesel engine pump

Painted metal casing (IP54) complete with:

- General door-locking switch.
Electronic unit for control and management of the diesel engine. Display of alarms and status, battery voltage, speedometer, hour counter, alarm programming, date display, main signals and manual start button.

PRODUCT DESCRIPTION BY TECHNICAL SPECIFICATIONS

- "MAN – AUT – 0" selector with extractable key only in automatic position.
- Pair of emergency battery start buttons.

Inside:

- Fuse holder and fuses for power and auxiliary circuits.
- Pair of battery chargers 12Vdc/24Vdc.
- Control unit for management of diesel engine and alarms.
- Auxiliary relays.
- Power circuits for engine heaters.
- Terminal boards.
- RS232 connector for communication port.
- Cable glands.
- Wiring diagram.

The panel is supplied standard with dry alarm signal contacts (max 1^a, 30Vdc/125vac/277Vac):

- Non-automatic operating mode.
- Controller fault.
- Motor running.
- Failure to start.
- General alarm.

Standard single-phase input voltage 1 x 230V.

Series of clean contacts for checking the status of the electric service pump panel, as well as the contacts already provided for signalling alarms (on request):

- No phase.
- Motor running..
- Selector position Man-Aut-0.
- Failure to start.
- Start-up request.

Series of clean contacts for checking the status of the electric jockey pump (on request)

- Pump running.
- Thermal shutdown (overload).
- No water.

Electrical alarms panel

Plastic casing protected to IP55 with an electronic board at the front for the visual and acoustic signalling of the status of one or two service pumps. The following alarms are signalled :

PRODUCT DESCRIPTION BY TECHNICAL SPECIFICATIONS

Electric pump

- Power off.
- Start-up request.
- Pump running.
- No start-up.

Diesel pump

- Non-automatic.
- Controller fault.
- Pump running.
- No start-up.

The electric panel is fitted with a buzzer with reset button, signal LED test button, battery charger and battery and is fitted out to signal the following general alarms, if present:

- General alarm for incorrect electrical connection in the exchange contacts of: status of flow measurement circuit valve, drain pump, jockey pump.
- Fault in electrical connection in the exchange contact relative to panel 1 (electric pump/diesel engine pump).
- Fault in electrical connection in the exchange contact relative to panel 2 (electric pump/diesel engine pump).
- Jockey pump overload.
- Jockey pump running.
- Discharge pump overload.
- Battery voltage low.
- Communications failure with ModBus system.

GSM modem system status transmission module and RS232/485 converter module available on request.

TECHNICAL SPECIFICATIONS	
DESCRIPTION	VALUE
Input voltage (single-phase)	(1F+N) 230V +/-10%, 50-60 Hz
Absorbed	0,1A
Dimensions	370 x 275 x 160 mm
Protection grade	IP55
Battery	Hermetic lead
Rated battery voltage	12 Vcc
Rated battery capacity	2,3 Ah (uncharged in 20 h)
Dimensions of battery	178 x 34 x 66 mm
Sound emission levels	75dB
Control panel weight	1,5kg

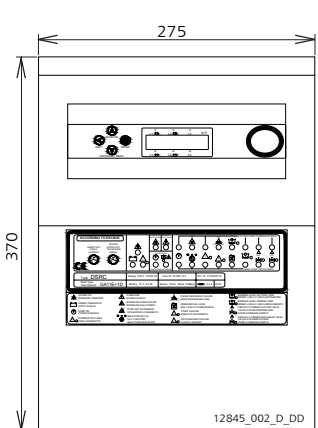

12845-qa1-en_b_td

➤ **Control instruments and hydraulic accessories**

The main components of the sets are:

- On/off valves on the delivery side of each pump, ball valves with lever handle for diameters up to 1 1/4" inclusive, butterfly valve with lever handle from DN65 to DN100 diameter, butterfly valve with handwheel and reduction manual gear for DN125 diameter and above.
- Re-circulation device for each service pump.

The re-circulation device allows a minimum capacity in order to prevent the pump overheating when working with closed delivery. It includes the activation pressure switch for the alarms of the pumps running, the test valve for checking the seal of the check valves, the couplings for any connecting pipes to the priming tank in the case of suction lift installation. The connection of each re-circulation to the suction tank or the priming tank is to be seen to by the person installing the equipment.

PRODUCT DESCRIPTION BY TECHNICAL SPECIFICATIONS

- Pressure gauge on the delivery side of each service pump between check valve and on/off valve.
- Check valve be inspected type, on the delivery side of each pump. Threaded connector up to and including a diameter of 1 1/4". Flanged connector for larger diameters.
- Painted iron delivery manifold (PN 16) and threaded stubs with relative caps for connecting any 24 litre membrane tanks. Blind and welding zinc-plated flanges.
- Two start-up pressure switches for every service pump.
For the electric service pumps, start-up takes place through the pressure switch, but it must be manually stopped using the key-operated selector switch on the panel (excluding the version with automatic shut-off).
For the electric jockey pump, if present, both start-up and stopping are determined by the pressure switch.
- Start-up pressure switch circuit for the service pump, including connecting pipes for the delivery manifold, recirculation circuit. This circuit includes on/off valve, a non-return valve, a discharge or test valve and various pipe fittings. The configuration of the circuit allows the pressure switch to intervene also when the relative on/off valve is closed.
- Various pipe fittings (copper, zinc-plated steel).
- Base made of bent sheet or structural iron with epoxy powder painting RAL 5010.
- Control panel frame made of structural iron with epoxy powder painting RAL 5010.

The control panels for the electric pumps up to 55 kW power supply are fixed on bracket. For higher powers, the control panels for electric pump service are floor mounted, instead the jockey electric pump panel is wall mounted fixed.

- Diesel engine with coupling to service pump.
- Vibration-damping joints on discharge side.
- Electric panel for control of diesel engine pump and battery charger.
- Diesel engine start circuit with two independent batteries.
- Double engine starting relay.
- Engine shut-off device from electric control (electric stop).
- Fuel tank for diesel engine.

PRODUCT DESCRIPTION BY TECHNICAL SPECIFICATIONS

- Electric panel for each electric service pump.

The diesel engine pump is mounted on its own base complete with vibration-damping feet, and comes with a wall-mounted electric panel fitted with 3-metre cables (5 metre length available on request), fuel tank with wall or floor mounting depending on capacity, floor-mounted batteries with iron frame to position to the side of the diesel engine. The installation of the diesel engine must provide for adequate ventilation and exhaust of combustion fumes.

Flow meter

The flow meter is supplied as part of the assembly kit. The EN 12845 standard requires the presence of the flow meter for checking the hydraulic performance during the test stage and duration periodic inspections. The kit comprises:

- Direct reading flow meter.
- On/off ball valve for diameters up to 2" inclusive, butterfly valve with lever handle from DN65 to DN100 diameter, butterfly valve with handwheel and reduction manual gear for DN125 diameter and above.
- Straight plastic connection piping.

The flow meter is available in various sizes according to the flow of a service pump and suitable for being connected to the offtake of the head manifold. For a correct match, identify the type as shown in the set size tables.

The assembly and the discharge piping towards the tank and discharge outlet are to be seen to by the person installing the equipment.

The following illustration shows the type and size of flow meter:

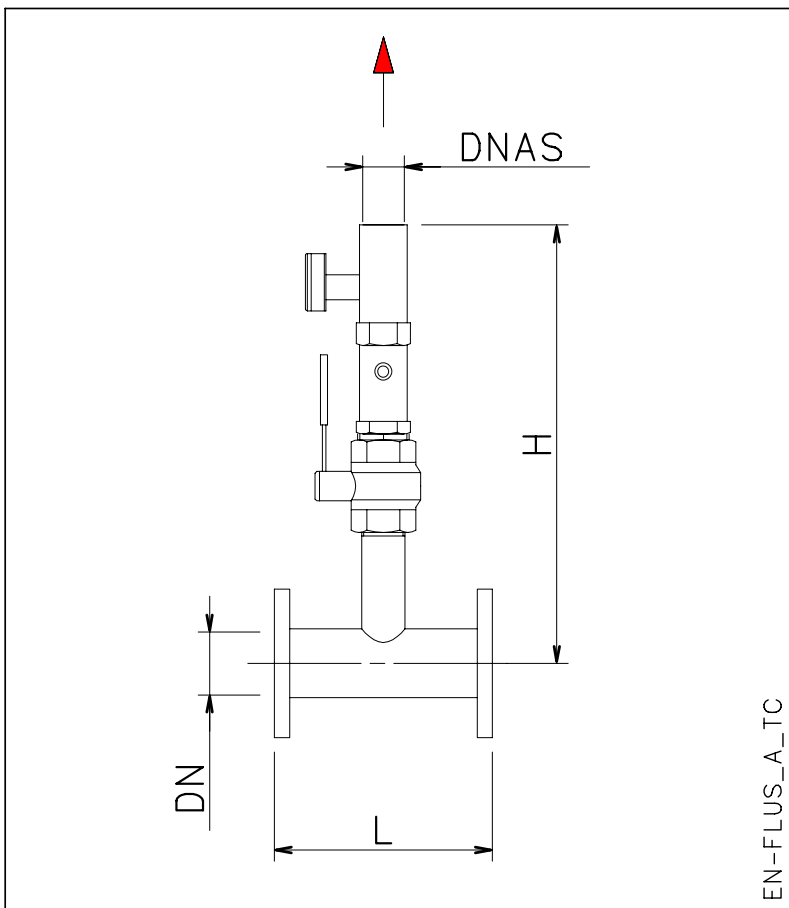

Dimensions (mm):

DN =
DNAS =
L =
H =
Qmax (m³/h) =

PRODUCT DESCRIPTION BY TECHNICAL SPECIFICATIONS

Diaphragm tanks

The booster sets are ready for installation, directly on the manifold, of 24-litre diaphragm tanks, one for each pump. The sets are also equipped with caps to close off the unused couplings. Larger tanks can also be connected to the unused end of the discharge manifold.

The kit is made up of the following accessories:

- Diaphragm tank;
- On-off ball valve;
- Instructions manual;
- Packaging.

Suction kit

The EN 12845 fire-fighting booster sets are supplied without valves and stubs on the suction side of the service pump and can be completed with suitable kits that depend on legal standards.

These requirements are expressed by EN 12845 (chapter 10.5 and chapter 10.6) and are connected with the maximum speed value of the water in the pipes, their minimum section and type of installation - suction lift or positive suction head. To provide for one suction kit for each duty pump.

The kit comprises:

- Anti-vibration joint to attach to the pump inlet.
- On/off butterfly valve (optional in case of positive suction head installation) with lever handle for diameters up to DN100, butterfly valve with handwheel and reduction manual gear for DN125 and higher.
- Eccentric cone.
- Vacuum pressure gauge.
- Weld-on flange.

The following illustration shows the suction kit:

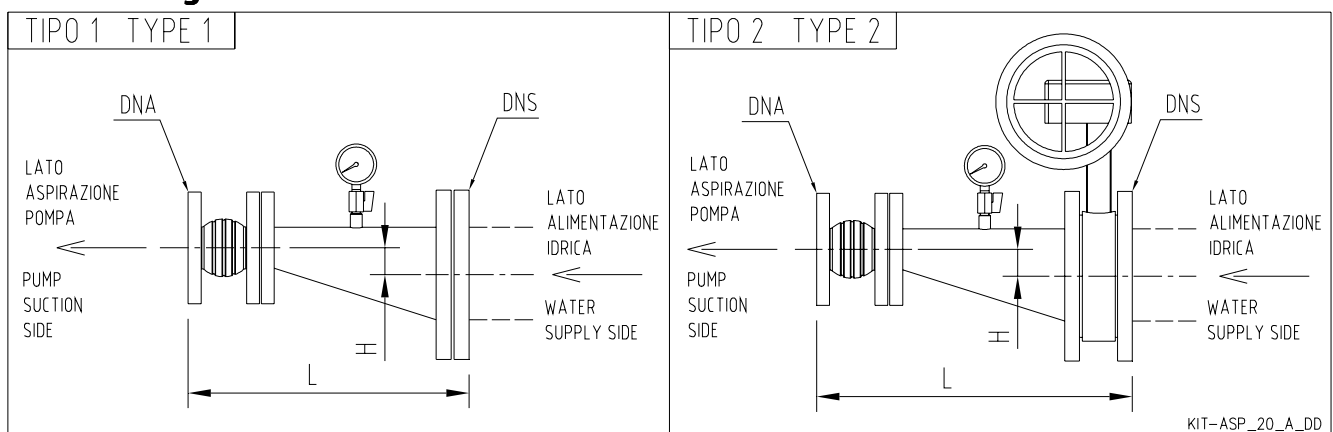

Dimensions (mm):

DNA =
DNS =

L =
H =

PRODUCT DESCRIPTION BY TECHNICAL SPECIFICATIONS

- **The set is supplied already assembled, calibrated and factory tested. The set is supplied complete with an instruction manual, pump manuals and wiring diagrams for the panels. For the sets including floor panels, the electric panels are sent together with the set in a separate pack and supplied with 5-metre long connecting cables (longer lengths available on request). The fitter is responsible for preparing the routes and installing the cables.**

FURTHER PRODUCT SELECTION AND DOCUMENTATION

Xylect

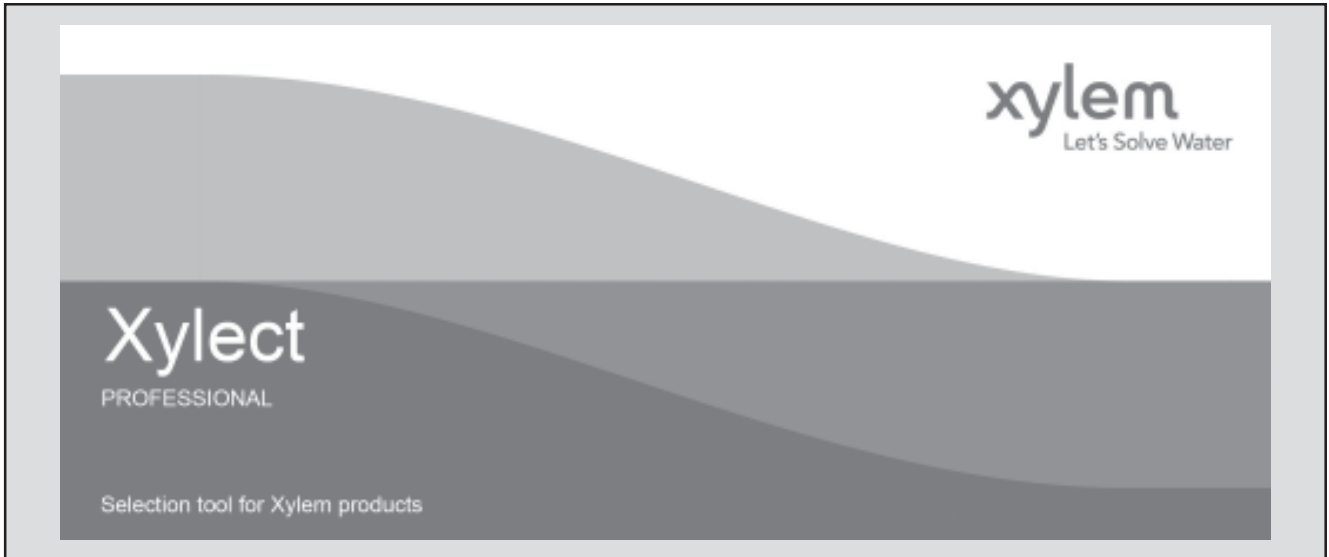

Xylect is pump solution selection software with an extensive online database of product information across the entire Lowara, and Vogel range of pumps and related products, with multiple search options and helpful project management facilities. The system holds up-to-date product information on thousands of products and accessories.

The possibility to search by applications and the detailed information output given makes it easy to make the optimal selection without having detailed knowledge about the Lowara and Vogel products.

The search can be made by:

- Application
- Product type
- Duty point

Xylect gives a detailed output:

- List with search results
- Performance curves (flow, head, power, efficiency, NPSH)
- Motor data
- Dimensional drawings
- Options
- Data sheet printouts
- Document downloads incl dxf files

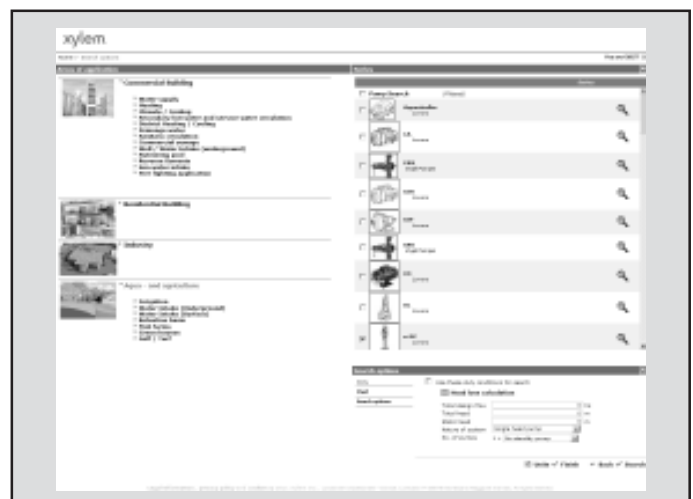

The search by application guides users not familiar with the product range to the right choice.

FURTHER PRODUCT SELECTION AND DOCUMENTATION

Xylect

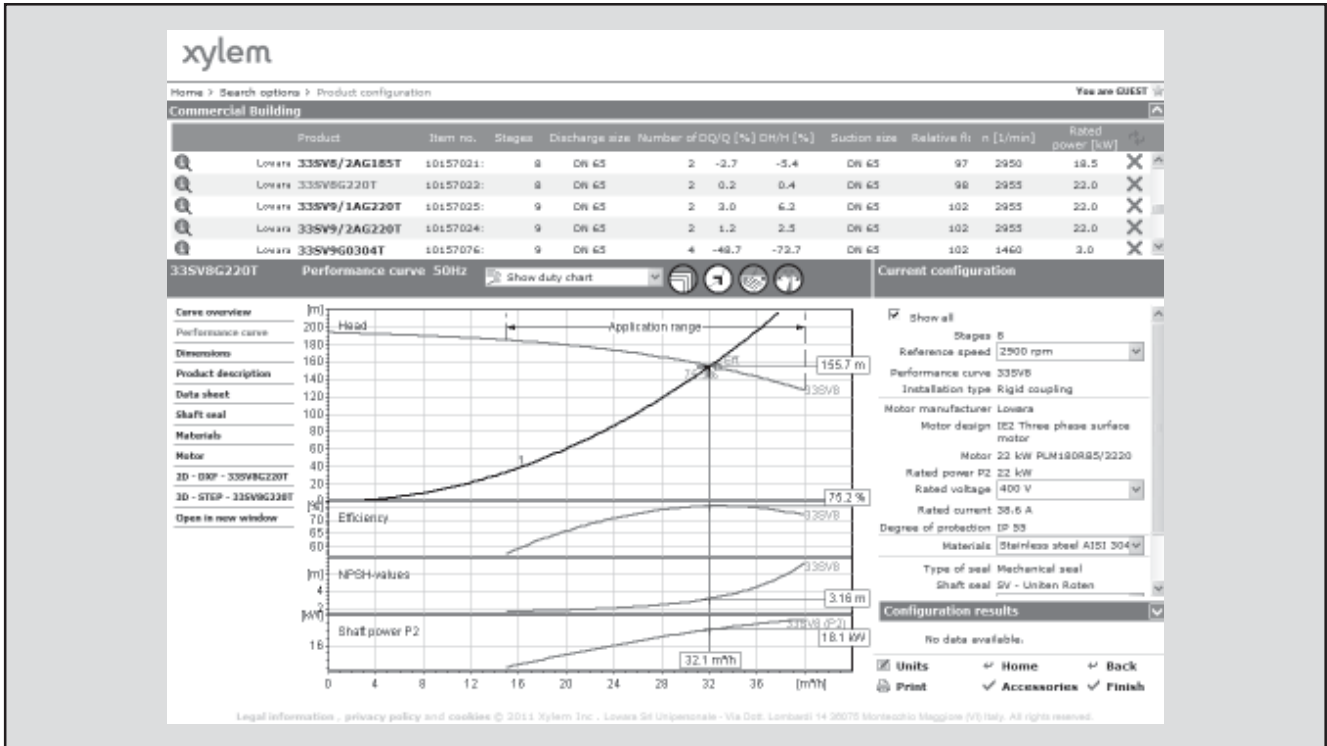

The detailed output makes it easy to select the optimal pump from the given alternatives.

The best way to work with Xylect is to create a personal account. This makes it possible to:

- Set own standard units
- Create and save projects
- Share projects with other Xylect users

Every user have a My Xylect space, where all projects are saved.

For more information about Xylect please contact our sales network or visit www.xylect.com.

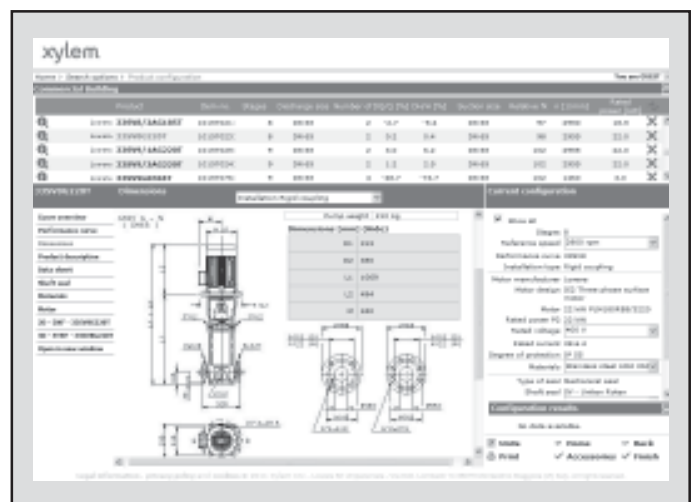

Dimensional drawings appear on the screen and can be downloaded in dxf format.

ACCESSORIES

Xylem |'zīləm|

- 1) The tissue in plants that brings water upward from the roots;
- 2) a leading global water technology company.

We're 12,000 people unified in a common purpose: creating innovative solutions to meet our world's water needs. Developing new technologies that will improve the way water is used, conserved, and re-used in the future is central to our work. We move, treat, analyze, and return water to the environment, and we help people use water efficiently, in their homes, buildings, factories and farms. In more than 150 countries, we have strong, long-standing relationships with customers who know us for our powerful combination of leading product brands and applications expertise, backed by a legacy of innovation.

For more information on how Xylem can help you, go to xylem.com.



Headquarters

LOWARA S.r.l. Unipersonale

Via Lombardi 14

36075 Montecchio Maggiore - Vicenza - Italy

Tel. (+39) 0444 707111 - Fax (+39) 0444 492166

e-mail: lowara.mkt@xylem.com

web: www.lowara.com - www.completewatersystems.com

LOWARA reserves the right to make modification without prior notice.
LOWARA is a trademark of Xylem Inc. or one of its subsidiaries.